

# **DIGITAL COMMUNICATIONS**

UNIT – I Pulse Code Modulation: Quantization Process, Quantization Noise, Pulse Code Modulation Line Codes Noise Considerations in PCM Systems Virtues, Limitations, and Modifications of PCM Delta Modulation, Differential Pulse Code Modulation, Adaptive differential Pulse Code Modulation. Base Band Pulse Transmission: Matched filter, Properties, Error Rate due to Noise Inter symbol interference, Nyquist's criterion for Distortion less Baseband Binary Transmission, Correlative level coding, Optimum Linear receiver Eye Pattern.

UNIT – II Digital Passband Transmission: Geometric representation of signals, Conversion of the continuous AWGN channel into A vector channel Likelihood Functions Maximum Likelihood decoding Correlation Receiver probability of error Passband Transmission model coherent BPSK, QPSK, M-PSK Coherent BFSK, MSK, GMSK Non Coherent BFSK DPSK Comparison of Digital Modulation Schemes. B.Tech. Electronics & Communication Engineering,

UNIT – III Spread Spectrum Modulation: PN sequence A Notion of spread spectrum direct Sequence spectrum spread spectrum with Coherent BPSK Signal Space Dimensionality and Processing gain Probability of error frequency Hop spread spectrum.

UNIT - IV Fundamental Limits in Information Theory: Uncertainty, Information, Entropy, Source Coding Theorem, Data Compaction, Discrete memoryless channels, Mutual information, Channel capacity, Channel coding theorem, Information capacity theorem, Data Compression.

UNIT – V Error Control Coding: Discrete Memoryless channels Linear Block codes, Cyclic Codes, Convolution Codes, Maximum Likelihood and Sequential Decoding of Convolution Codes.

#### TEXT BOOKS:

- 1) Simon Haykin, Communication Systems, 4th edition John Wiley & Sons, 2001
- 2) Modern Digital and Analog Communication Systems, 3rd edition, OUP, 1998
- 3) Leon W Couch II, Digital and Analog Communication Systems, 6th Edition, Pearson, 2004.

#### REFERENCE BOOKS:

- 1) John G Proakis, Digital Communications, 4th Edition, McGraw Hill, 2001.
- 2) Bernard Sklar, Digital Communication, 2nd Edition, Pearson Education, 2001.
- 3) Taub and Schilling, Principles of Communication Systems, 2nd Edition, TMH, 1986

## UNIT-1

### Digital Pulse Modulation

#### Elements of Digital Communication Systems:

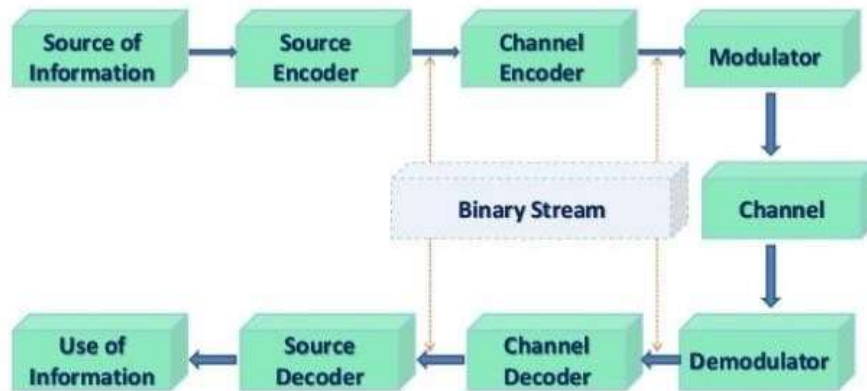

Fig. 1 Elements of Digital Communication Systems

#### 1. Information Source and Input Transducer:

The source of information can be analog or digital, e.g. analog: audio or video signal, digital: like teletype signal. In digital communication the signal produced by this source is converted into digital signal which consists of 1's and 0's. For this we need a source encoder.

#### 2. Source Encoder:

In digital communication we convert the signal from source into digital signal as mentioned above. The point to remember is we should like to use as few binary digits as possible to represent the signal. In such a way this efficient representation of the source output results in little or no redundancy. This sequence of binary digits is called *information sequence*.

*Source Encoding or Data Compression:* the process of efficiently converting the output of whether analog or digital source into a sequence of binary digits is known as source encoding.

### 3. Channel Encoder:

The information sequence is passed through the channel encoder. The purpose of the channel encoder is to introduce, in controlled manner, some redundancy in the binary information sequence that can be used at the receiver to overcome the effects of noise and interference encountered in the transmission on the signal through the channel.

For example take  $k$  bits of the information sequence and map that  $k$  bits to unique  $n$  bit sequence called code word. The amount of redundancy introduced is measured by the ratio  $n/k$  and the reciprocal of this ratio ( $k/n$ ) is known as *rate of code or code rate*.

### 4. Digital Modulator:

The binary sequence is passed to digital modulator which in turns convert the sequence into electric signals so that we can transmit them on channel (we will see channel later). The digital modulator maps the binary sequences into signal wave forms , for example if we represent 1 by  $\sin x$  and 0 by  $\cos x$  then we will transmit  $\sin x$  for 1 and  $\cos x$  for 0. ( a case similar to BPSK)

### 5. Channel:

The communication channel is the physical medium that is used for transmitting signals from transmitter to receiver. In wireless system, this channel consists of atmosphere , for traditional telephony, this channel is wired , there are optical channels, under water acoustic channels etc.We further discriminate this channels on the basis of their property and characteristics, like AWGN channel etc.

### 6. Digital Demodulator:

The digital demodulator processes the channel corrupted transmitted waveform and reduces the waveform to the sequence of numbers that represents estimates of the transmitted data symbols.

### 7. Channel Decoder:

This sequence of numbers then passed through the channel decoder which attempts to reconstruct the original information sequence from the knowledge of the code used by the channel encoder and the redundancy contained in the received data

***Note: The average probability of a bit error at the output of the decoder is a measure of the performance of the demodulator – decoder combination.***

### 8. Source Decoder:

At the end, if an analog signal is desired then source decoder tries to decode the sequence from the knowledge of the encoding algorithm. And which results in the approximate replica of the input at the transmitter end.

### 9. Output Transducer:

Finally we get the desired signal in desired format analog or digital.

#### Advantages of digital communication:

- Can **withstand channel noise and distortion** much better as long as the noise and the distortion are within limits.
- **Regenerative repeaters** prevent accumulation of noise along the path.
- Digital **hardware implementation is flexible**.
- Digital signals **can be coded** to yield extremely **low error rates, high fidelity** and well as **privacy**.
- Digital communication is inherently more efficient than analog in realizing the exchange of SNR for bandwidth.
- It is easier and more **efficient to multiplex** several digital signals.
- Digital signal **storage is relatively easy and inexpensive**.
- **Reproduction** with digital messages is extremely reliable **without deterioration**.
- The **cost** of digital hardware continues to halve every two or three years, while **performance or capacity doubles** over the same time period.

#### Disadvantages

- **TDM** digital transmission is **not compatible with the FDM**
- A Digital system requires **large bandwidth**.

## Introduction to Pulse Modulation

What is the need for Pulse Modulation?

- Many Signals in Modern Communication Systems are digital
- Also, analog signals are transmitted digitally.
- Reduced distortion and improvement in signal to noise ratios.
- PAM, PWM, PPM, PCM and DM.
- In CW modulation schemes some parameter of modulated wave varies continuously with message.
- In Analog pulse modulation some parameter of each pulse is modulated by a particular sample value of the message.
- Pulse modulation is of two types
  - Analog Pulse Modulation
    - Pulse Amplitude Modulation (PAM)
    - Pulse width Modulation (PWM)
    - Pulse Position Modulation (PPM)
  - Digital Pulse Modulation
    - Pulse code Modulation (PCM)
    - Delta Modulation (DM)

## PULSE MODULATION

- **Pulse Amplitude Modulation**
- **Pulse Width Modulation**
- **Pulse Position Modulation**
- **Pulse Code Modulation**
- **Delta Modulation**

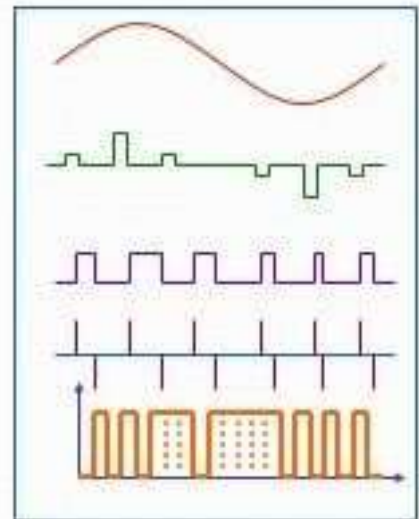

### Pulse Code Modulation:

Three steps involved in conversion of analog signal to digital signal

- Sampling
- Quantization
- Binary encoding

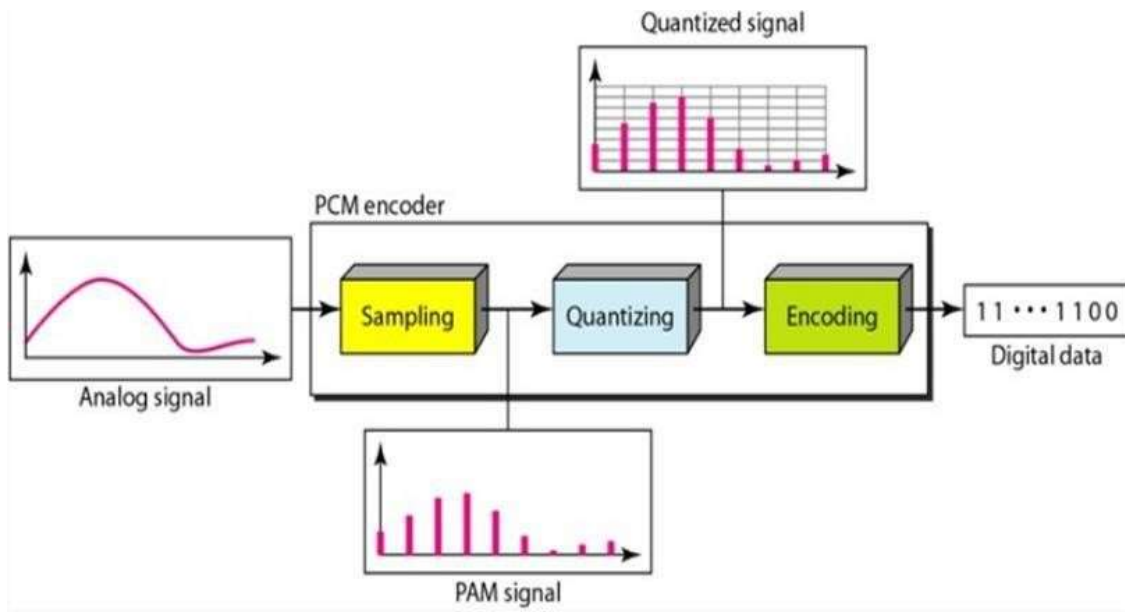

Fig. 2 Conversion of Analog Signal to Digital Signal

**Note:** Before sampling the signal is filtered to limit bandwidth.

**Elements of PCM System:**

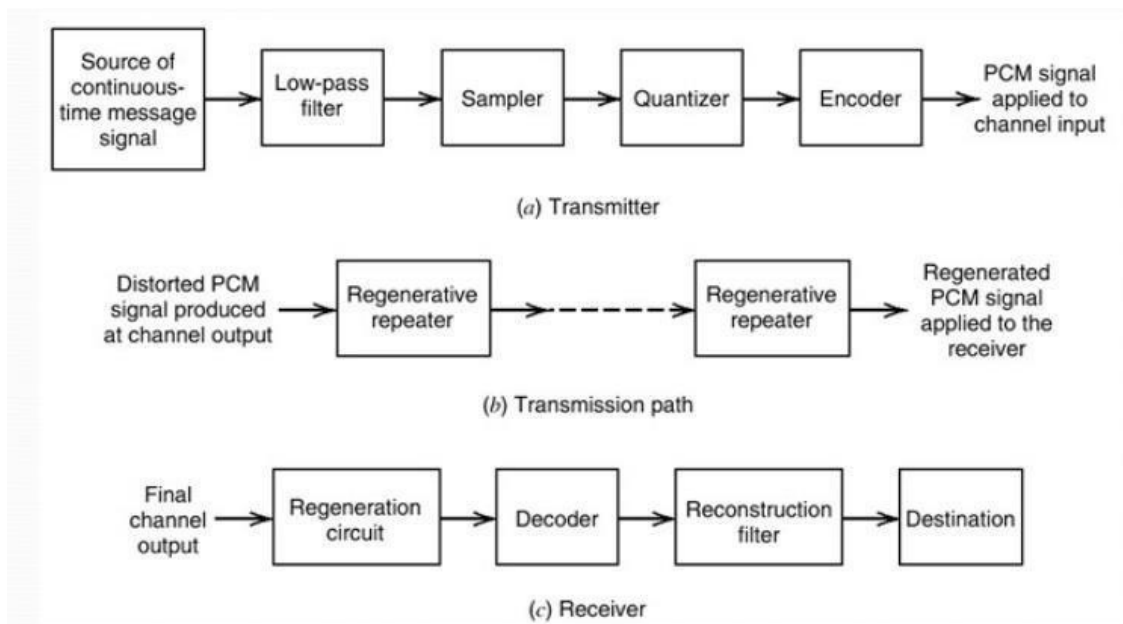

Fig. 3 Elements of PCM System

**Sampling:**

- Process of converting analog signal into discrete signal.
- Sampling is common in all pulse modulation techniques

- The signal is sampled at regular intervals such that each sample is proportional to amplitude of signal at that instant
- Analog signal is sampled every  $T_s$  Secs, called sampling interval.  $f_s=1/T_s$  is called sampling rate or sampling frequency.
- $f_s=2f_m$  is Min. sampling rate called **Nyquist rate**. Sampled spectrum ( $\omega$ ) is repeating periodically without overlapping.
- Original spectrum is centered at  $\omega=0$  and having bandwidth of  $\omega_m$ . Spectrum can be recovered by passing through low pass filter with cut-off  $\omega_m$ .
- For  $f_s < 2f_m$  sampled spectrum will overlap and cannot be recovered back. This is called **aliasing**.

### Sampling methods:

- Ideal – An impulse at each sampling instant.
- Natural – A pulse of Short width with varying amplitude.
- Flat Top – Uses sample and hold, like natural but with single amplitude value.

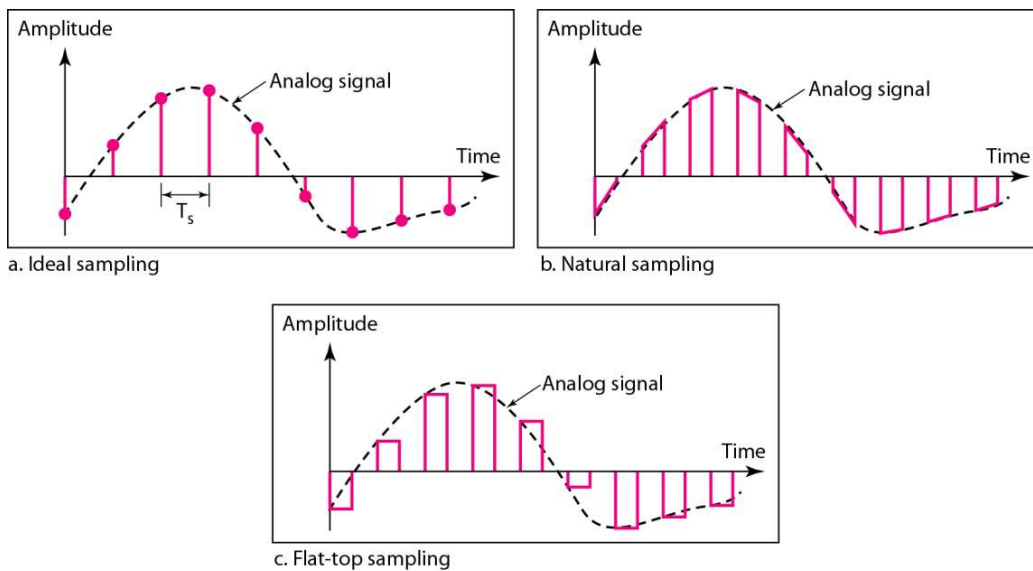

Fig. 4 Types of Sampling

### Sampling of band-pass Signals:

- A band-pass signal of bandwidth  $2f_m$  can be completely recovered from its samples.

Min. sampling rate  $= 2 \times \text{Bandwidth}$

$$= 2 \times 2f_m = 4f_m$$

- Range of minimum sampling frequencies is in the range of  $2 \times BW$  to  $4 \times BW$

### Instantaneous Sampling or Impulse Sampling:

- Sampling function is train of spectrum remains constant impulses throughout frequency range. It is not practical.



### Natural sampling:

- The spectrum is weighted by a **sinc** function.
- Amplitude of high frequency components reduces.

### Flat top sampling:

- Here top of the samples remains constant.
- In the spectrum high frequency components are attenuated due sinc pulse roll off. This is known as **Aperture effect**.
- If pulse width increases aperture effect is more i.e. more attenuation of high frequency components.

Sampling Theorem:

### **Statement of sampling theorem**

- 1) *A band limited signal of finite energy, which has no frequency components higher than  $W$  Hertz, is completely described by specifying the values of the signal at instants of time separated by  $\frac{1}{2W}$  seconds and*
- 2) *A band limited signal of finite energy, which has no frequency components higher than  $W$  Hertz, may be completely recovered from the knowledge of its samples taken at the rate of  $2W$  samples per second.*

The first part of above statement tells about sampling of the signal and second part tells about reconstruction of the signal. Above statement can be combined and stated alternately as follows :

*A continuous time signal can be completely represented in its samples and recovered back if the sampling frequency is twice of the highest frequency content of the signal. i.e.,*

$$f_s \geq 2W$$

Here  $f_s$  is the sampling frequency and

$W$  is the higher frequency content

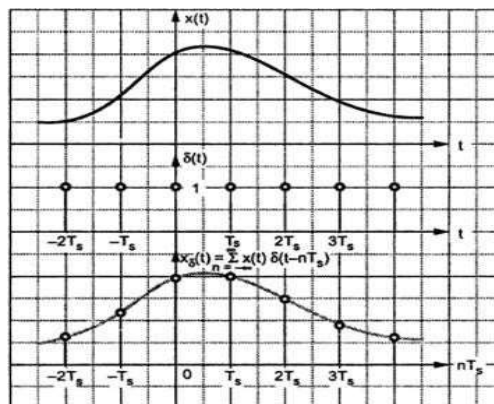

Fig. 5 CT and its DT signal

### Proof of sampling theorem

- There are two parts : (I) Representation of  $x(t)$  in terms of its samples  
(II) Reconstruction of  $x(t)$  from its samples.

#### Part I : Representation of $x(t)$ in its samples $x(nT_s)$

Step 1 : Define  $x_\delta(t)$   
Step 2 : Fourier transform of  $x_\delta(t)$  i.e.  $X_\delta(f)$   
Step 3 : Relation between  $X(f)$  and  $X_\delta(f)$   
Step 4 : Relation between  $x(t)$  and  $x(nT_s)$

#### Step 1 : Define $x_\delta(t)$

The sampled signal  $x_\delta(t)$  is given as,

$$x_\delta(t) = \sum_{n=-\infty}^{\infty} x(t) \delta(t-nT_s) \quad \dots 1$$

Here observe that  $x_\delta(t)$  is the product of  $x(t)$  and impulse train  $\delta(t)$  as shown in above fig In the above equation  $\delta(t-nT_s)$  indicates the samples placed at  $\pm T_s, \pm 2T_s, \pm 3T_s \dots$  and so on.

#### Step 2 : FT of $x_\delta(t)$ i.e. $X_\delta(f)$

Taking FT of equation (1.3.1).

$$\begin{aligned} X_\delta(f) &= \text{FT} \left\{ \sum_{n=-\infty}^{\infty} x(t) \delta(t-nT_s) \right\} \\ &= \text{FT} \{ \text{Product of } x(t) \text{ and impulse train} \} \end{aligned}$$

We know that FT of product in time domain becomes convolution in frequency domain. i.e.,

$$X_\delta(f) = \text{FT} \{x(t)\} * \text{FT} \{\delta(t-nT_s)\} \quad \dots \dots \dots 2$$

By definitions,  $x(t) \xrightarrow{\text{FT}} X(f)$  and

$$\delta(t-nT_s) \xrightarrow{\text{FT}} f_s \sum_{n=-\infty}^{\infty} \delta(f-nf_s)$$

Hence equation (1.3.2) becomes,

$$X_\delta(f) = X(f) * f_s \sum_{n=-\infty}^{\infty} \delta(f-nf_s)$$

Since convolution is linear,

$$X_\delta(f) = f_s \sum_{n=-\infty}^{\infty} X(f) * \delta(f-nf_s)$$

$$= f_s \sum_{n=-\infty}^{\infty} X(f-nf_s) \quad \text{By shifting property of impulse function}$$

$$= \dots f_s X(f-2f_s) + f_s X(f-f_s) + f_s X(f) + f_s X(f-f_s) + f_s X(f-2f_s) + \dots$$

### Comments

- (i) The RHS of above equation shows that  $X(f)$  is placed at  $\pm f_s, \pm 2f_s, \pm 3f_s, \dots$
- (ii) This means  $X(f)$  is periodic in  $f_s$ .
- (iii) If sampling frequency is  $f_s = 2W$ , then the spectrums  $X(f)$  just touch each other.

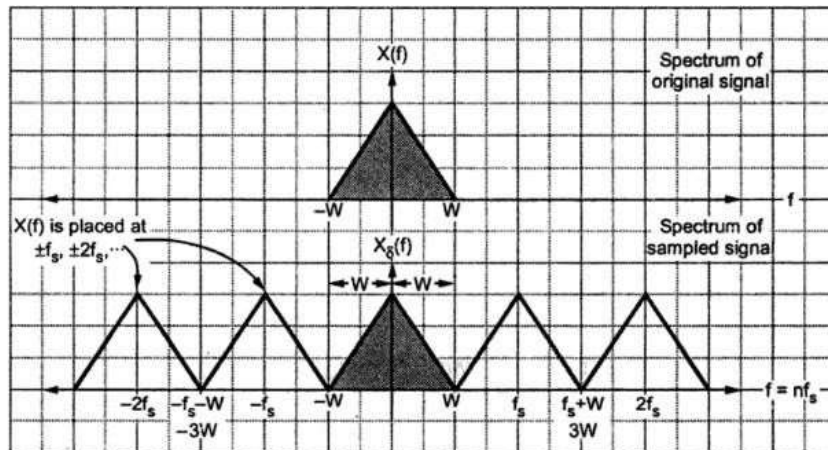

Fig. 6 Spectrum of original signal and sampled signal

### Step 3 : Relation between $X(f)$ and $X_\delta(f)$

**Important assumption :** Let us assume that  $f_s = 2W$ , then as per above diagram.

$$X_\delta(f) = f_s X(f) \quad \text{for } -W \leq f \leq W \text{ and } f_s = 2W$$

or

$$X(f) = \frac{1}{f_s} X_\delta(f) \quad \dots \quad 3$$

### Step 4 : Relation between $x(t)$ and $x(nT_s)$

DTFT is,

$$X(\Omega) = \sum_{n=-\infty}^{\infty} x(n) e^{-j\Omega n}$$

$$\therefore X(f) = \sum_{n=-\infty}^{\infty} x(n) e^{-j2\pi f n} \quad \dots \quad 4$$

In above equation 'f' is the frequency of DT signal. If we replace  $X(f)$  by  $X_{\delta}(f)$ , then 'f' becomes frequency of CT signal. i.e.,

$$X_{\delta}(f) = \sum_{n=-\infty}^{\infty} x(n) e^{-j2\pi \frac{f}{f_s} n}$$

In above equation 'f' is frequency of CT signal. And  $\frac{f}{f_s}$  = Frequency of DT signal in equation 4. Since  $x(n) = x(nT_s)$ , i.e. samples of  $x(t)$ , then we have,

$$X_{\delta}(f) = \sum_{n=-\infty}^{\infty} x(nT_s) e^{-j2\pi f n T_s} \text{ since } \frac{1}{f_s} = T_s$$

Putting above expression in equation 3 ,

$$X(f) = \frac{1}{f_s} \sum_{n=-\infty}^{\infty} x(nT_s) e^{-j2\pi f n T_s}$$

Inverse Fourier Transform (IFT) of above equation gives  $x(t)$  i.e.,

$$x(t) = IFT \left\{ \frac{1}{f_s} \sum_{n=-\infty}^{\infty} x(nT_s) e^{-j2\pi f n T_s} \right\} \quad \dots \quad 5$$

**Comments :**

- i) Here  $x(t)$  is represented completely in terms of  $x(nT_s)$ .
- ii) Above equation holds for  $f_s = 2W$ . This means if the samples are taken at the rate of  $2W$  or higher,  $x(t)$  is completely represented by its samples.
- iii) First part of the sampling theorem is proved by above two comments.

**Part II : Reconstruction of  $x(t)$  from its samples**

Step 1 : Take inverse Fourier transform of  $X(f)$  which is in terms of  $X_{\delta}(f)$ .  
 Step 2 : Show that  $x(t)$  is obtained back with the help of interpolation function.

**Step 1 :** The IFT of equation 5 becomes,

$$x(t) = \int_{-\infty}^{\infty} \left\{ \frac{1}{f_s} \sum_{n=-\infty}^{\infty} x(nT_s) e^{-j2\pi f n T_s} \right\} e^{j2\pi f t} df$$

Here the integration can be taken from  $-W \leq f \leq W$ . Since  $X(f) = \frac{1}{f_s} X_{\delta}(f)$  for  $-W \leq f \leq W$ . (See Fig. 6 ).

$$\therefore x(t) = \int_{-W}^W \frac{1}{f_s} \sum_{n=-\infty}^{\infty} x(nT_s) e^{-j2\pi f n T_s} \cdot e^{j2\pi f t} df$$

Interchanging the order of summation and integration,

$$\begin{aligned} x(t) &= \sum_{n=-\infty}^{\infty} x(nT_s) \frac{1}{f_s} \int_{-W}^W e^{j2\pi f(t-nT_s)} df \\ &= \sum_{n=-\infty}^{\infty} x(nT_s) \cdot \frac{1}{f_s} \left[ \frac{e^{j2\pi f(t-nT_s)}}{j2\pi(t-nT_s)} \right]_{-W}^W \\ &= \sum_{n=-\infty}^{\infty} x(nT_s) \cdot \frac{1}{f_s} \left\{ \frac{e^{j2\pi W(t-nT_s)} - e^{-j2\pi W(t-nT_s)}}{j2\pi(t-nT_s)} \right\} \\ &= \sum_{n=-\infty}^{\infty} x(nT_s) \cdot \frac{1}{f_s} \cdot \frac{\sin 2\pi W(t-nT_s)}{\pi(t-nT_s)} \\ &= \sum_{n=-\infty}^{\infty} x(nT_s) \frac{\sin \pi(2Wt - 2WnT_s)}{\pi(f_s t - f_s n T_s)} \end{aligned}$$

Here  $f_s = 2W$ , hence  $T_s = \frac{1}{f_s} = \frac{1}{2W}$ . Simplifying above equation,

$$\begin{aligned} x(t) &= \sum_{n=-\infty}^{\infty} x(nT_s) \frac{\sin \pi(2Wt - n)}{\pi(2Wt - n)} \\ &= \sum_{n=-\infty}^{\infty} x(nT_s) \text{sinc}(2Wt - n) \quad \text{since } \frac{\sin \pi \theta}{\pi \theta} = \text{sinc } \theta \quad \dots \quad 6 \end{aligned}$$

**Step 2 :** Let us interpret the above equation. Expanding we get,

$$x(t) = \dots + x(-2T_s) \text{sinc}(2Wt + 2) + x(-T_s) \text{sinc}(2Wt + 1) + x(0) \text{sinc}(2Wt) + x(T_s) \text{sinc}(2Wt - 1) + \dots$$

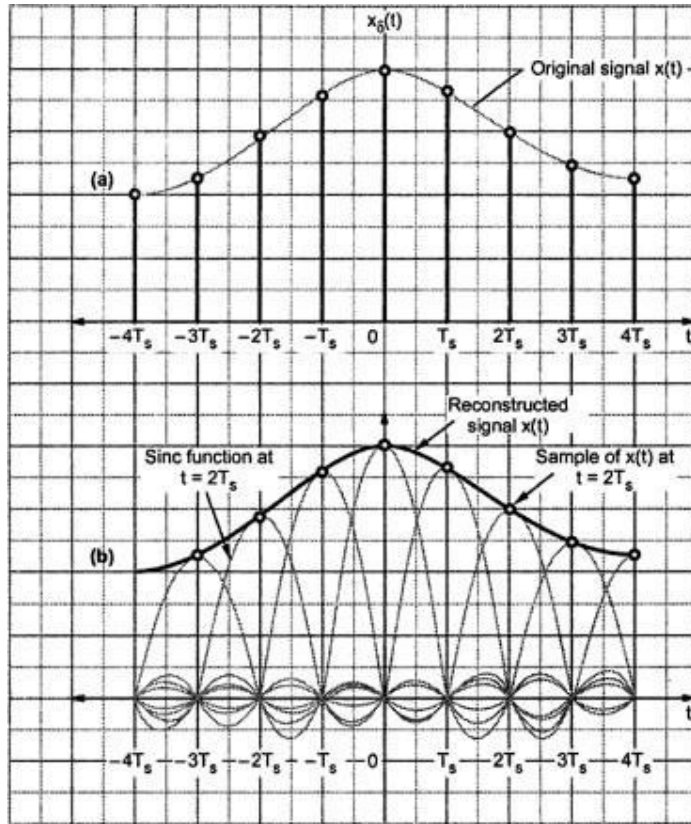

Fig. 7 (a) Sampled version of signal  $x(t)$   
 (b) Reconstruction of  $x(t)$  from its samples

**Comments :**

- i) The samples  $x(nT_s)$  are weighted by sinc functions.
- ii) The sinc function is the interpolating function. Fig. 7 shows, how  $x(t)$  is interpolated.

**Step 3 : Reconstruction of  $x(t)$  by lowpass filter**

When the interpolated signal of equation 6 is passed through the lowpass filter of bandwidth  $-W \leq f \leq W$ , then the reconstructed waveform shown in above Fig. 7(b) is obtained. The individual sinc functions are interpolated to get smooth  $x(t)$ .

## PCM Generator:

The pulse code modulator technique samples the input signal  $x(t)$  at frequency  $f_s \geq 2W$ . This sampled 'Variable amplitude' pulse is then digitized by the analog to digital converter. The parallel bits obtained are converted to a serial bit stream. Fig. 8 shows the PCM generator.

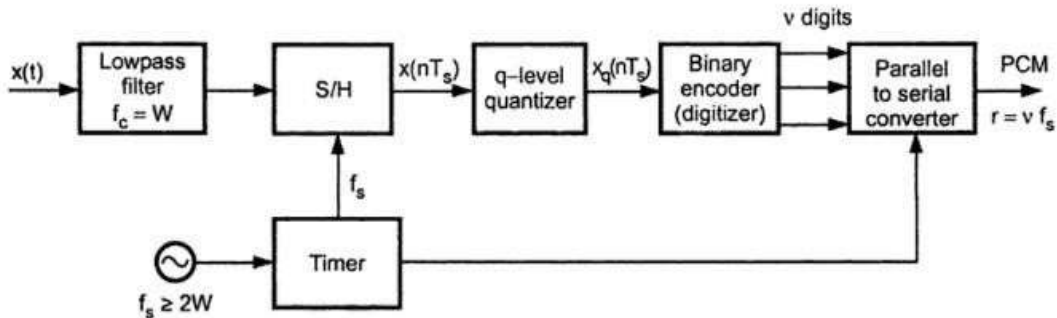

Fig. 8 PCM generator

In the PCM generator of above figure, the signal  $x(t)$  is first passed through the lowpass filter of cutoff frequency 'W' Hz. This lowpass filter blocks all the frequency components above 'W' Hz. Thus  $x(t)$  is bandlimited to 'W' Hz. The sample and hold circuit then samples this signal at the rate of  $f_s$ . Sampling frequency  $f_s$  is selected sufficiently above Nyquist rate to avoid aliasing i.e.,

$$f_s \geq 2W$$

In Fig. 8 output of sample and hold is called  $x(nT_s)$ . This  $x(nT_s)$  is discrete in time and continuous in amplitude. A q-level quantizer compares input  $x(nT_s)$  with its fixed digital levels. It assigns any one of the digital level to  $x(nT_s)$  with its fixed digital levels. It then assigns any one of the digital level to  $x(nT_s)$  which results in minimum distortion or error. This error is called *quantization error*. Thus output of quantizer is a digital level called  $x_q(nT_s)$ .

Now coming back to our discussion of PCM generation, the quantized signal level  $x_q(nT_s)$  is given to binary encoder. This encoder converts input signal to 'v' digits binary word. Thus  $x_q(nT_s)$  is converted to 'V' binary bits. The encoder is also called digitizer.

It is not possible to transmit each bit of the binary word separately on transmission line. Therefore 'v' binary digits are converted to serial bit stream to generate single baseband signal. In a parallel to serial converter, normally a shift register does this job. The output of PCM generator is thus a single baseband signal of binary bits.

An oscillator generates the clocks for sample and hold an parallel to serial converter. In the pulse code modulation generator discussed above ; sample and hold, quantizer and encoder combinely form an analog to digital converter.

**Transmission BW in PCM:**

Let the quantizer use 'v' number of binary digits to represent each level. Then the number of levels that can be represented by 'v' digits will be,

$$q = 2^v \quad \dots \quad 1$$

Here 'q' represents total number of digital levels of q-level quantizer.

For example if v=3 bits, then total number of levels will be,

$$q = 2^3 = 8 \text{ levels}$$

Each sample is converted to 'v' binary bits. i.e. Number of bits per sample = v

We know that, Number of samples per second =  $f_s$

∴ Number of bits per second is given by,

$$\begin{aligned} \text{(Number of bits per second)} &= \text{(Number of bits per samples)} \\ &\quad \times \text{(Number of samples per second)} \\ &= v \text{ bits per sample} \times f_s \text{ samples per second} \quad \dots \quad 2 \end{aligned}$$

The number of bits per second is also called signaling rate of PCM and is denoted by 'r' i.e.,

Signaling rate in PCM : $r = v f_s$	... 3
-------------------------------------	-------

Here  $f_s \geq 2W$ .

Bandwidth needed for PCM transmission will be given by half of the signaling rate i.e.,

$$\text{Transmission Bandwidth of PCM : } \begin{cases} B_T \geq \frac{1}{2} r & \dots \quad 4 \\ B_T \geq \frac{1}{2} v f_s & \text{Since } f_s \geq 2W \quad \dots \quad 5 \\ B_T \geq v W & \dots \quad 6 \end{cases}$$



## PCM Receiver:

Fig. 9 (a) shows the block diagram of PCM receiver and Fig. 9 (b) shows the reconstructed signal. The regenerator at the start of PCM receiver reshapes the pulses and removes the noise. This signal is then converted to parallel **digital** words for each sample.

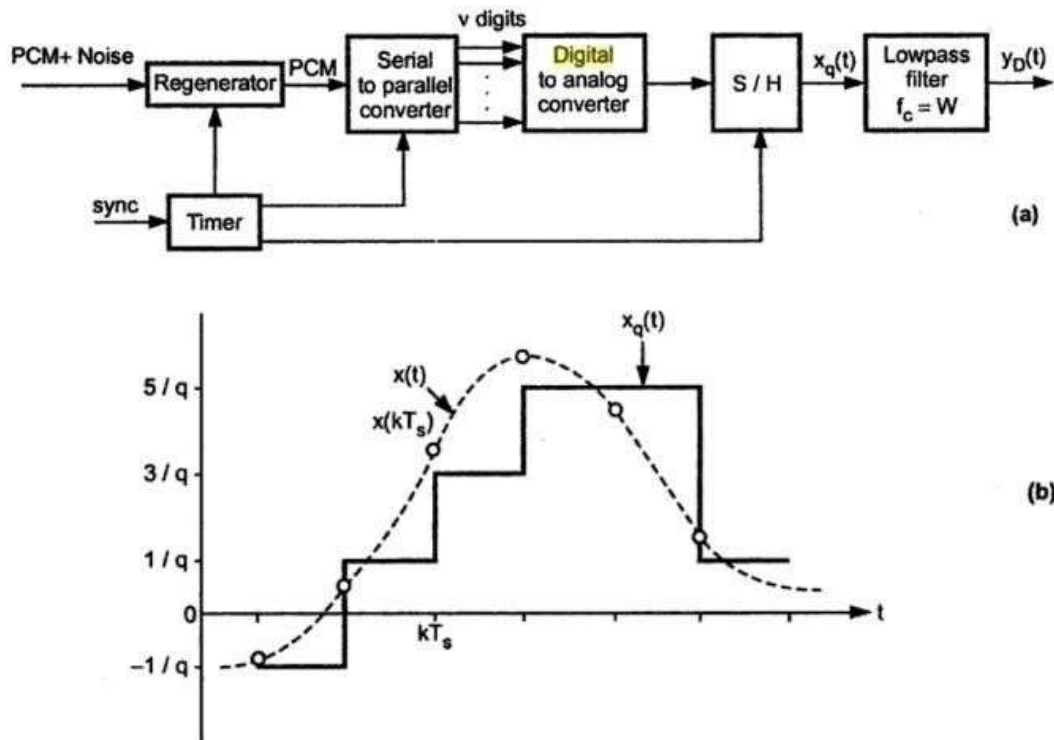

**Fig. 9 (a) PCM receiver**  
**(b) Reconstructed waveform**

The **digital** word is converted to its analog value  $x_q(t)$  along with sample and hold. This signal, at the output of S/H is passed through lowpass reconstruction filter to get  $y_D(t)$ . As shown in reconstructed signal of Fig. 9 (b), it is impossible to reconstruct exact original signal  $x(t)$  because of permanent quantization error introduced during quantization at the transmitter. This quantization error can be reduced by increasing the binary levels. This is equivalent to increasing binary digits (bits) per sample. But increasing bits ' $v$ ' increases the signaling rate as well as transmission bandwidth as we have seen in equation 3 and equation 6. Therefore the choice of these parameters is made, such that noise due to quantization error (called as quantization noise) is in tolerable limits.

## Quantization

- The quantizing of an analog signal is done by discretizing the signal with a number of quantization levels.

- **Quantization** is representing the sampled values of the amplitude by a finite set of levels, which means converting a continuous-amplitude sample into a discrete-time signal
- Both sampling and quantization result in the loss of information.
- The quality of a Quantizer output depends upon the number of quantization levels used.
- The discrete amplitudes of the quantized output are called as **representation levels** or **reconstruction levels**.
- The spacing between the two adjacent representation levels is called a **quantum** or **step-size**.
- There are two types of Quantization
  - Uniform Quantization
  - Non-uniform Quantization.
- The type of quantization in which the quantization levels are uniformly spaced is termed as a **Uniform Quantization**.
- The type of quantization in which the quantization levels are unequal and mostly the relation between them is logarithmic, is termed as a **Non-uniform Quantization**.

#### Uniform Quantization:

- There are two types of uniform quantization.
  - Mid-Rise type
  - Mid-Tread type.
- The following figures represent the two types of uniform quantization.

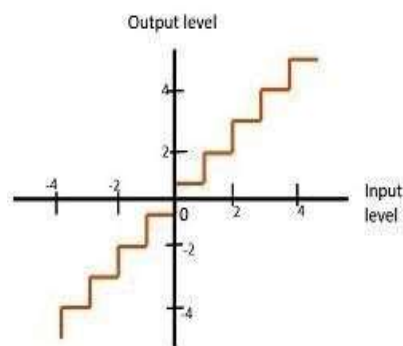

Fig 1 : Mid-Rise type Uniform Quantization

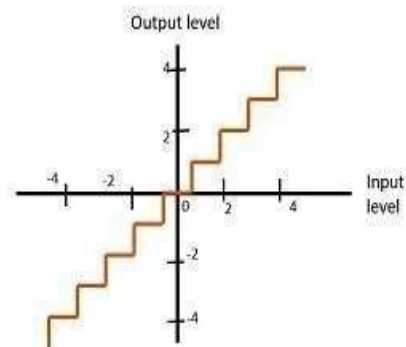

Fig 2 : Mid-Tread type Uniform Quantization

- The **Mid-Rise** type is so called because the origin lies in the middle of a raising part of the stair-case like graph. The quantization levels in this type are even in number.
- The **Mid-tread** type is so called because the origin lies in the middle of a tread of the stair-case like graph. The quantization levels in this type are odd in number.
- Both the mid-rise and mid-tread type of uniform quantizer is symmetric about the origin.

## Quantization Noise and Signal to Noise ratio in PCM System:

### Derivation of Quantization Error/Noise or Noise Power for Uniform (Linear) Quantization

#### Step 1 : Quantization Error

Because of quantization, inherent errors are introduced in the signal. This error is called *quantization error*. We have defined quantization error as,

$$\epsilon = x_q(nT_s) - x(nT_s) \quad \dots\dots\dots(1)$$

#### Step 2 : Step size

Let an input  $x(nT_s)$  be of continuous amplitude in the range  $-x_{\max}$  to  $+x_{\max}$ .

Therefore the total amplitude range becomes,

$$\begin{aligned} \text{Total amplitude range} &= x_{\max} - (-x_{\max}) \quad \dots\dots\dots(2) \\ &= 2x_{\max} \end{aligned}$$

If this amplitude range is divided into 'q' levels of quantizer, then the step size 'δ' is given as,

$$\begin{aligned} \delta &= \frac{x_{\max} - (-x_{\max})}{q} \\ &= \frac{2x_{\max}}{q} \quad \dots\dots\dots(3) \end{aligned}$$

If signal  $x(t)$  is normalized to minimum and maximum values equal to 1, then

$$\begin{aligned} x_{\max} &= 1 \\ -x_{\max} &= -1 \quad \dots\dots\dots(4) \end{aligned}$$

Therefore step size will be,

$$\delta = \frac{2}{q} \quad (\text{for normalized signal}) \quad \dots\dots\dots(5)$$

#### Step 3 : Pdf of Quantization error

If step size 'δ' is sufficiently small, then it is reasonable to assume that the quantization error 'ε' will be uniformly distributed random variable. The maximum quantization error is given by

$$\epsilon_{\max} = \frac{|\delta|}{2} \quad \dots\dots\dots(6)$$

i.e.  $-\frac{\delta}{2} \geq \epsilon_{\max} \geq \frac{\delta}{2} \quad \dots\dots\dots(7)$

Thus over the interval  $\left(-\frac{\delta}{2}, \frac{\delta}{2}\right)$  quantization error is uniformly distributed random variable.

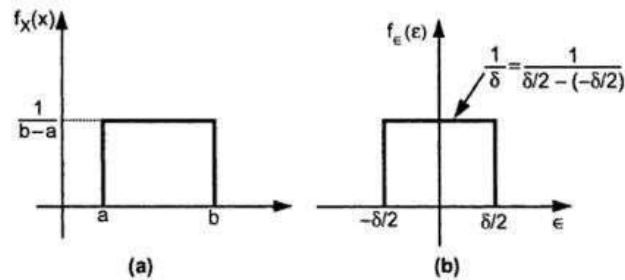

**Fig. 10 (a) Uniform distribution**  
**(b) Uniform distribution for quantization error**

In above figure, a random variable is said to be uniformly distributed over an interval (a, b). Then PDF of 'X' is given by, (from equation of Uniform PDF).

$$f_X(x) = \begin{cases} 0 & \text{for } x \leq a \\ \frac{1}{b-a} & \text{for } a < x \leq b \\ 0 & \text{for } x > b \end{cases} \dots\dots\dots(8)$$

Thus with the help of above equation we can define the probability density function for quantization error 'ε' as,

$$f_\epsilon(\epsilon) = \begin{cases} 0 & \text{for } \epsilon \leq \frac{\delta}{2} \\ \frac{1}{\delta} & \text{for } -\frac{\delta}{2} < \epsilon \leq \frac{\delta}{2} \\ 0 & \text{for } \epsilon > \frac{\delta}{2} \end{cases} \dots\dots\dots(9)$$

#### Step 4 : Noise Power

quantization error 'e' has zero average value.

That is mean ' $m_e$ ' of the quantization error is zero.

The signal to quantization noise ratio of the quantizer is defined as,

$$\frac{S}{N} = \frac{\text{Signal power (normalized)}}{\text{Noise power (normalized)}} \quad \dots 10$$

If type of signal at input i.e.,  $x(t)$  is known, then it is possible to calculate signal power.

The noise power is given as,

$$\text{Noise power} = \frac{V_{noise}^2}{R} \quad \dots (11)$$

Here  $V_{noise}^2$  is the mean square value of noise voltage. Since noise is defined by random variable 'e' and PDF  $f_e(\epsilon)$ , its mean square value is given as,

$$\text{mean square value} = E[\epsilon^2] = \bar{\epsilon}^2 \quad \dots (12)$$

The mean square value of a random variable 'X' is given as,

$$\bar{X}^2 = E[X^2] = \int_{-\infty}^{\infty} x^2 f_X(x) dx \quad \text{By definition} \quad \dots (13)$$

$$\text{Here} \quad E[\epsilon^2] = \int_{-\infty}^{\infty} \epsilon^2 f_e(\epsilon) d\epsilon \quad \dots (14)$$

From equation 9 we can write above equation as,

$$\begin{aligned} E[\epsilon^2] &= \int_{-\delta/2}^{\delta/2} \epsilon^2 \times \frac{1}{\delta} d\epsilon \\ &= \frac{1}{\delta} \left[ \frac{\epsilon^3}{3} \right]_{-\delta/2}^{\delta/2} = \frac{1}{\delta} \left[ \frac{(\delta/2)^3}{3} + \frac{(\delta/2)^3}{3} \right] \\ &= \frac{1}{3\delta} \left[ \frac{\delta^3}{8} + \frac{\delta^3}{8} \right] = \frac{\delta^2}{12} \quad \dots (15) \end{aligned}$$

∴ From equation 1.8.25, the mean square value of noise voltage is,

$$V_{noise}^2 = \text{mean square value} = \frac{\delta^2}{12}$$

When load resistance,  $R = 1$  ohm, then the noise power is normalized i.e.,

$$\begin{aligned} \text{Noise power (normalized)} &= \frac{V_{noise}^2}{1} && \text{[with } R = 1 \text{ in equation 11 ]} \\ &= \frac{\delta^2 / 12}{1} = \frac{\delta^2}{12} \end{aligned}$$

Thus we have,

**Normalized noise power**

**or Quantization noise power =  $\frac{\delta^2}{12}$  ; For linear quantization.**

**or Quantization error (in terms of power)**

... (16)

**Derivation of Maximum Signal to Quantization Noise Ratio for Linear Quantization:**

signal to quantization noise ratio is given as,

$$\begin{aligned} \frac{S}{N} &= \frac{\text{Normalized signal power}}{\text{Normalized noise power}} \\ &= \frac{\text{Normalized signal power}}{(\delta^2 / 12)} \end{aligned} \quad \dots (17)$$

The number of bits 'v' and quantization levels 'q' are related as,

$$q = 2^v \quad \dots (18)$$

Putting this value in equation (3) we have,

$$\delta = \frac{2 x_{\max}}{2^v} \quad \dots (19)$$

Putting this value in equation 1.8.30 we get,

$$\frac{S}{N} = \frac{\text{Normalized signal power}}{\left( \frac{2 x_{\max}}{2^v} \right)^2 + 12}$$

Let normalized signal power be denoted as 'P'.

$$\frac{S}{N} = \frac{P}{\frac{4 x_{\max}^2}{2^{2v}} \times \frac{1}{12}} = \frac{3P}{x_{\max}^2} \cdot 2^{2v}$$

This is the required relation for maximum signal to quantization noise ratio. Thus,

$$\text{Maximum signal to quantization noise ratio : } \frac{S}{N} = \frac{3P}{x_{\max}^2} \cdot 2^{2v} \quad \dots (20)$$

This equation shows that signal to noise power ratio of quantizer increases exponentially with increasing bits per sample.

If we assume that input  $x(t)$  is normalized, i.e.,

$$x_{\max} = 1 \quad \dots (21)$$

Then signal to quantization noise ratio will be,

$$\frac{S}{N} = 3 \times 2^{2v} \times P \quad \dots (22)$$

If the destination signal power 'P' is normalized, i.e.,

$$P \leq 1 \quad \dots (23)$$

Then the signal to noise ratio is given as,

$$\frac{S}{N} \leq 3 \times 2^{2v} \quad \dots (24)$$

Since  $x_{\max} = 1$  and  $P \leq 1$ , the signal to noise ratio given by above equation is normalized.

Expressing the signal to noise ratio in decibels,

$$\begin{aligned} \left(\frac{S}{N}\right)_{dB} &= 10 \log_{10} \left(\frac{S}{N}\right)_{dB} \quad \text{since power ratio.} \\ &\leq 10 \log_{10} [3 \times 2^{2v}] \\ &\leq (4.8 + 6v) \text{ dB} \end{aligned}$$

Thus,

$$\begin{aligned} &\text{Signal to Quantization noise ratio} \\ &\text{for normalized values of power : } \left(\frac{S}{N}\right)_{dB} \leq (4.8 + 6v) \text{ dB} \\ &\text{'P' and amplitude of input } x(t) \end{aligned} \quad \dots (25)$$

### Non-Uniform Quantization:

In non-uniform quantization, the step size is not fixed. It varies according to certain law or as per input signal amplitude. The following fig shows the characteristics of Non uniform quantizer.

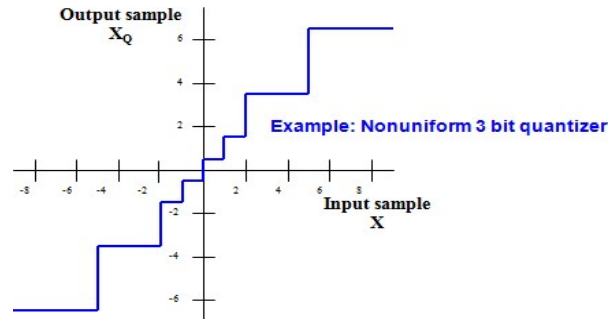

In this figure observe that step size is small at low input signal levels. Hence quantization error is also small at these inputs. Therefore signal to quantization noise power ratio is improved at low signal levels. Stepsize is higher at high input levels. Hence signal to noise power ratio remains almost same throughout the dynamic range of quantizer.

### Companding PCM System:

- Non-uniform quantizers are difficult to make and expensive.
- An alternative is to first pass the speech signal through nonlinearity before quantizing with a uniform quantizer.
- The nonlinearity causes the signal amplitude to be **compressed**.
  - The input to the quantizer will have a more uniform distribution.
- At the receiver, the signal is **expanded** by an inverse to the nonlinearity.
- The process of compressing and expanding is called **Companding**.

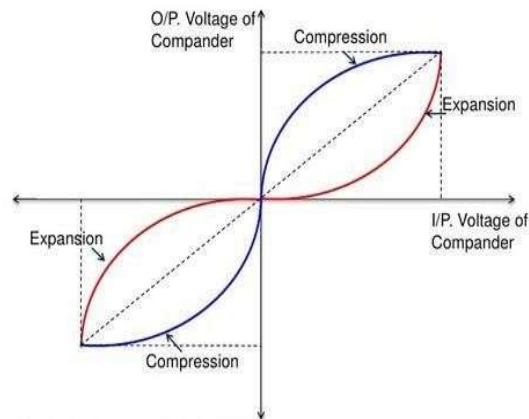



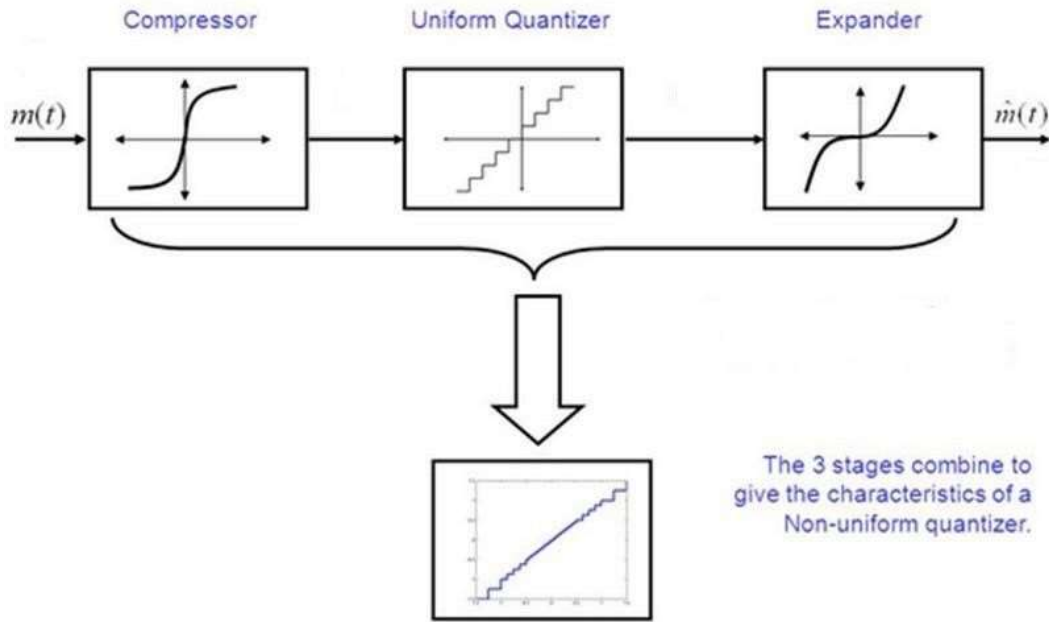

**$\mu$  - Law Companding for Speech Signals**

Normally for speech and music signals a  $\mu$  - law compression is used. This compression is defined by the following equation,

$$Z(x) = (\text{Sgn } x) \frac{\ln(1 + \mu |x|)}{\ln(1 + \mu)} |x| \leq 1 \quad \dots (1)$$

Below Fig shows the variation of signal to noise ratio with respect to signal level without companding and with companding.

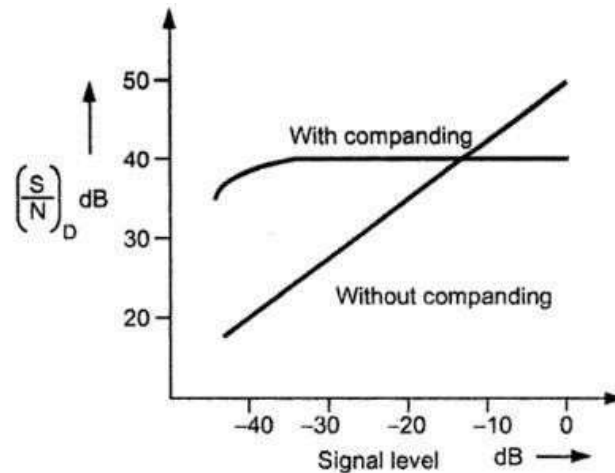

**Fig. 11 PCM performance with  $\mu$  - law companding**

It can be observed from above figure that signal to noise ratio of PCM remains almost constant with companding.

#### A-Law for Companding

The A law provides piecewise compressor characteristic. It has linear segment for low level inputs and logarithmic segment for high level inputs. It is defined as,

$$Z(x) = \begin{cases} \frac{A|x|}{1+\ln A} & \text{for } 0 \leq |x| \leq \frac{1}{A} \\ \frac{1+\ln(A|x|)}{1+\ln A} & \text{for } \frac{1}{A} \leq |x| \leq 1 \end{cases} \quad \dots (2)$$

When  $A = 1$ , we get uniform quantization. The practical value for  $A$  is 87.56. Both A-law and  $\mu$ -law companding is used for PCM telephone systems.

#### Signal to Noise Ratio of Companded PCM

The signal to noise ratio of companded PCM is given as,

$$\frac{S}{N} = \frac{3q^2}{[\ln(1+\mu)]^2} \quad \dots (3)$$

Here  $q = 2^v$  is number of quantization levels.

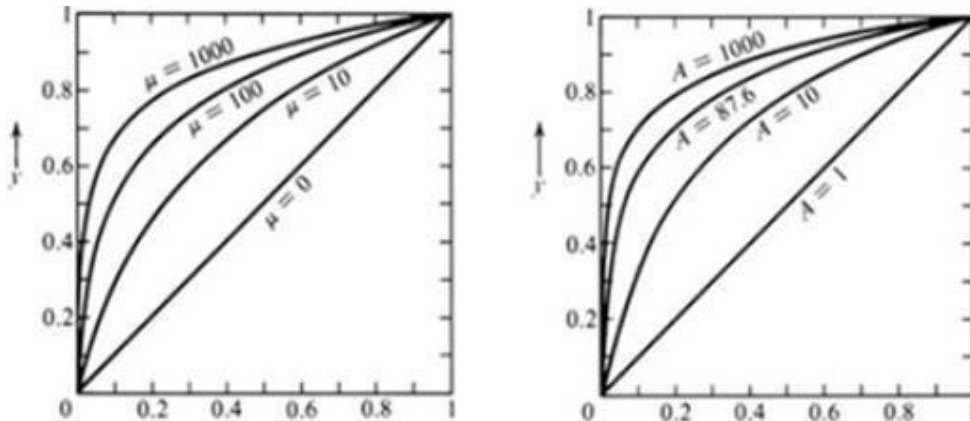

#### Differential Pulse Code Modulation (DPCM):

Redundant Information in PCM:

The samples of a signal are highly correlated with each other. This is because any signal does not change fast. That is its value from present sample to next sample does not differ by large amount. The adjacent samples of the signal carry the same information with little difference. When these samples are encoded by standard PCM system, the resulting encoded signal contains redundant information.

Fig. shows a continuous time signal  $x(t)$  by dotted line. This signal is sampled by flat top sampling at intervals  $T_s, 2T_s, 3T_s, \dots, nT_s$ . The sampling frequency is selected to be higher than nyquist rate. The samples are encoded by using 3 bit (7 levels) PCM. The sample is quantized to the nearest digital level as shown by small

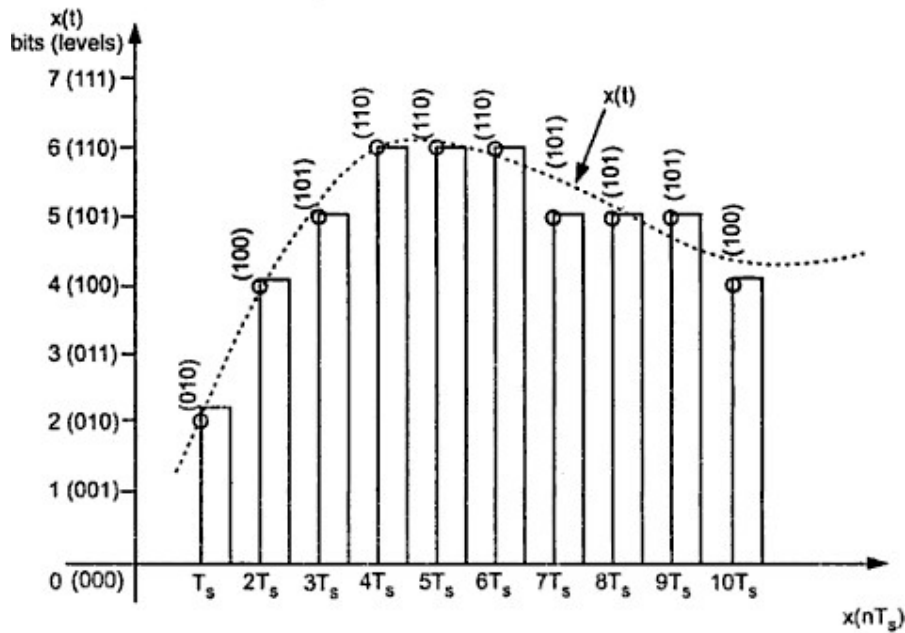

Fig. Redundant information in PCM

circles in the diagram. The encoded binary value of each sample is written on the top of the samples. We can see from Fig. that the samples taken at  $4T_s, 5T_s$  and  $6T_s$  are encoded to same value of (110). This information can be carried only by one sample. But three samples are carrying the same information means it is redundant. Consider another example of samples taken at  $9T_s$  and  $10T_s$ . The difference between these samples is only due to last bit and first two bits are redundant, since they do not change.

### Principle of DPCM

If this redundancy is reduced, then overall bit rate will decrease and number of bits required to transmit one sample will also be reduced. This type of digital pulse modulation scheme is called Differential Pulse Code Modulation.

### DPCM Transmitter

The differential pulse code modulation works on the principle of prediction. The value of the present sample is predicted from the past samples. The prediction may not be exact but it is very close to the actual sample value. Fig. shows the transmitter of Differential Pulse Code Modulation (DPCM) system. The sampled signal is denoted by  $x(nT_s)$  and the predicted signal is denoted by  $\hat{x}(nT_s)$ . The comparator finds out the difference between the actual sample value  $x(nT_s)$  and predicted sample value  $\hat{x}(nT_s)$ . This is called error and it is denoted by  $e(nT_s)$ . It can be defined as,

$$e(nT_s) = x(nT_s) - \hat{x}(nT_s) \quad \dots\dots\dots(1)$$

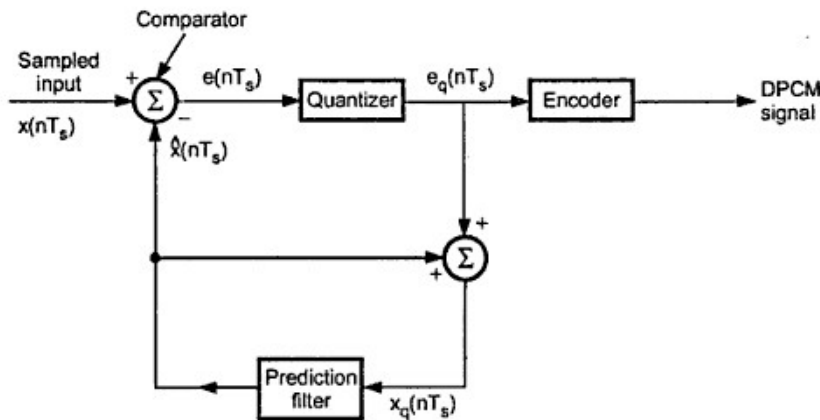

Fig. Differential pulse code modulation transmitter

Thus error is the difference between unquantized input sample  $x(nT_s)$  and prediction of it  $\hat{x}(nT_s)$ . The predicted value is produced by using a prediction filter. The quantizer output signal  $e_q(nT_s)$  and previous prediction is added and given as

input to the prediction filter. This signal is called  $x_q(nT_s)$ . This makes the prediction more and more close to the actual sampled signal. We can see that the quantized error signal  $e_q(nT_s)$  is very small and can be encoded by using small number of bits. Thus number of bits per sample are reduced in DPCM.

The quantizer output can be written as,

$$e_q(nT_s) = e(nT_s) + q(nT_s) \quad \dots\dots\dots(2)$$

Here  $q(nT_s)$  is the quantization error. As shown in Fig. the prediction filter input  $x_q(nT_s)$  is obtained by sum  $\hat{x}(nT_s)$  and quantizer output i.e.,

$$x_q(nT_s) = \hat{x}(nT_s) + e_q(nT_s) \quad \dots\dots\dots(3)$$

Putting the value of  $e_q(nT_s)$  from equation 2 in the above equation we get,

$$x_q(nT_s) = \hat{x}(nT_s) + e(nT_s) + q(nT_s) \quad \dots\dots\dots(4)$$

Equation 1 is written as,

$$e(nT_s) = x(nT_s) - \hat{x}(nT_s)$$

$$\therefore e(nT_s) + \hat{x}(nT_s) = x(nT_s) \quad \dots\dots\dots(5)$$

$\therefore$  Putting the value of  $e(nT_s) + \hat{x}(nT_s)$  from above equation into equation 4 we get,

$$x_q(nT_s) = x(nT_s) + q(nT_s) \quad \dots\dots\dots(6)$$

Thus the quantized version of the signal  $x_q(nT_s)$  is the sum of original sample value and quantization error  $q(nT_s)$ . The quantization error can be positive or negative. Thus equation 6 does not depend on the prediction filter characteristics.

### Reconstruction of DPCM Signal

Fig. shows the block diagram of DPCM receiver.

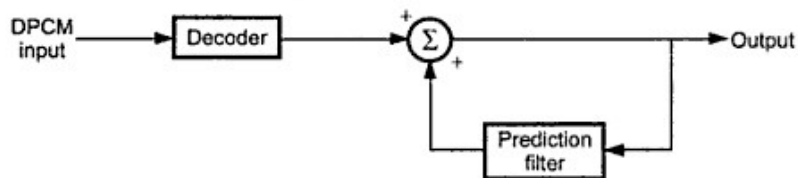

Fig. DPCM receiver

The decoder first reconstructs the quantized error signal from incoming binary signal. The prediction filter output and quantized error signals are summed up to give the quantized version of the original signal. Thus the signal at the receiver differs from actual signal by quantization error  $q(nT_s)$ , which is introduced permanently in the reconstructed signal.

### Line Coding:

In telecommunication, a line code is a code chosen for use within a communications system for transmitting a digital signal down a transmission line. Line coding is often used for digital data transport.

The waveform pattern of voltage or current used to represent the 1s and 0s of a digital signal on a transmission link is called line encoding. The common types of

line encoding are unipolar, polar, bipolar and Manchester encoding. Line codes are used commonly in computer communication networks over short distances.

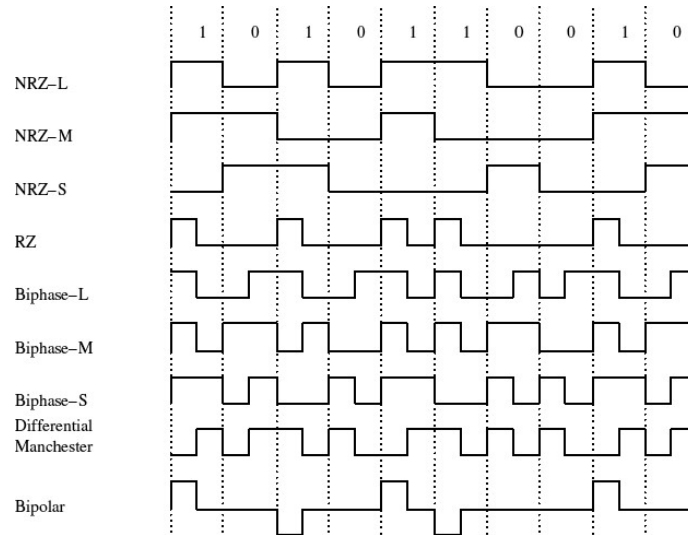

Signal	Comments
NRZ-L	Non-return to zero level. This is the standard positive logic signal format used in digital circuits. 1 forces a high level 0 forces a low level
NRZ-M	Non return to zero mark 1 forces a transition 0 does nothing
NRZ-S	Non return to zero space 1 does nothing 0 forces a transition
RZ	Return to zero 1 goes high for half the bit period 0 does nothing
Biphase-L	Manchester. Two consecutive bits of the same type force a transition at the beginning of a bit period. 1 forces a negative transition in the middle of the bit 0 forces a positive transition in the middle of the bit
Biphase-M	There is always a transition at the beginning of a bit period. 1 forces a transition in the middle of the bit 0 does nothing
Biphase-S	There is always a transition at the beginning of a bit period. 1 does nothing 0 forces a transition in the middle of the bit
Differential Manchester	There is always a transition in the middle of a bit period. 1 does nothing 0 forces a transition at the beginning of the bit
Bipolar	The positive and negative pulses alternate. 1 forces a positive or negative pulse for half the bit period 0 does nothing

## Time Division Multiplexing:

The sampling theorem provides the basis for transmitting the information contained in a band-limited message signal  $m(t)$  as a sequence of samples of  $m(t)$  taken uniformly at a rate that is usually slightly higher than the Nyquist rate. An important feature of the sampling process is a *conservation of time*. That is, the transmission of the message samples engages the communication channel for only a fraction of the sampling interval on a periodic basis, and in this way some of the time interval between adjacent samples is cleared for use by other independent message sources on a time-shared basis. We thereby obtain a *time-division multiplex (TDM) system*, which enables the joint utilization of a common communication channel by a plurality of independent message sources without mutual interference among them.

The concept of TDM is illustrated by the block diagram shown in Figure . Each input message signal is first restricted in bandwidth by a low-pass anti-aliasing filter to remove the frequencies that are nonessential to an adequate signal representation. The low-pass filter outputs are then applied to a *commutator*, which is usually implemented using electronic switching circuitry. The function of the commutator is twofold: (1) to take a narrow sample of each of the  $N$  input messages at a rate  $f_s$  that is slightly higher than  $2W$ , where  $W$  is the cutoff frequency of the anti-aliasing filter, and (2) to sequentially interleave these  $N$  samples inside the sampling interval  $T_s$ . Indeed, this latter function is the essence of the time-division multiplexing operation. Following the commutation process, the multiplexed signal is applied to a *pulse modulator*, the purpose of which is to transform the multiplexed signal into a form suitable for transmission over the common channel. It is clear that the use of time-division multiplexing introduces a bandwidth expansion factor  $N$ , because the scheme must squeeze  $N$  samples derived from  $N$  independent message sources into a time slot equal to one sampling interval. At the receiving end of the system, the received signal is applied to a *pulse demodulator*, which performs the reverse operation of the pulse modulator. The narrow samples produced at the pulse demodulator output are distributed to the appropriate low-pass reconstruction filters by means of a *decommutator*, which operates in *synchronism* with the commutator in the transmitter. This synchronization is essential for a satisfactory operation of the system.

The way this synchronization is implemented depends naturally on the method of pulse modulation used to transmit the multiplexed sequence of samples.

The TDM system is highly sensitive to dispersion in the common channel, that is, to variations of amplitude with frequency or lack of proportionality of phase with frequency. Accordingly, accurate equalization of both magnitude and phase responses of the channel is necessary to ensure a satisfactory operation of the system;

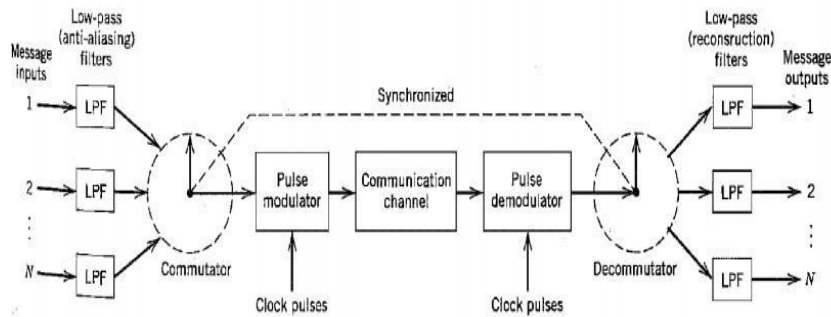

**FIGURE** Block diagram of TDM system.

TDM is immune to nonlinearities in the channel as a source of crosstalk. The reason for this behaviour is that different message signals are not simultaneously applied to the channel.

## Introduction to Delta Modulation

PCM transmits all the bits which are used to code the sample. Hence signaling rate and transmission channel bandwidth are large in PCM. To overcome this problem Delta Modulation is used.

### Delta Modulation

#### Operating Principle of DM

Delta modulation transmits only one bit per sample. That is the present sample value is compared with the previous sample value and the indication, whether the amplitude is increased or decreased is sent. Input signal  $x(t)$  is approximated to step signal by the delta modulator. This step size is fixed. The difference between the input signal  $x(t)$  and staircase approximated signal confined to two levels, i.e.  $+\delta$  and  $-\delta$ . If the difference is positive, then approximated signal is increased by one step i.e. ' $\delta$ '. If the difference is negative, then approximated signal is reduced by ' $\delta$ '. When the step is reduced, '0' is transmitted and if the step is increased, '1' is transmitted. Thus for each sample, only one binary bit is transmitted. Fig. shows the analog signal  $x(t)$  and its staircase approximated signal by the delta modulator.



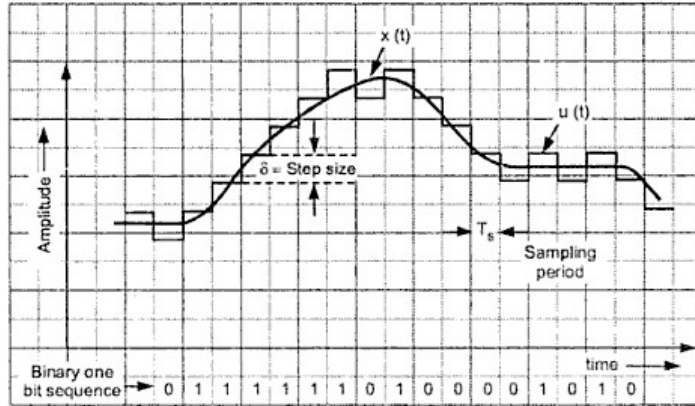

Fig. Delta modulation waveform

The principle of delta modulation can be explained by the following set of equations. The error between the sampled value of  $x(t)$  and last approximated sample is given as,

$$e(nT_s) = x(nT_s) - \hat{x}(nT_s) \quad \dots (1)$$

Here,  $e(nT_s)$  = Error at present sample

$x(nT_s)$  = Sampled signal of  $x(t)$

$\hat{x}(nT_s)$  = Last sample approximation of the staircase waveform.

We can call  $u(nT_s)$  as the present sample approximation of staircase output.

$$\text{Then, } u[(n-1)T_s] = \hat{x}(nT_s) \quad \dots (2)$$

= Last sample approximation of staircase waveform.

Let the quantity  $b(nT_s)$  be defined as,

$$b(nT_s) = \delta \operatorname{sgn}[e(nT_s)] \quad \dots (3)$$

That is depending on the sign of error  $e(nT_s)$  the sign of step size  $\delta$  will be decided. In other words,

$$\begin{aligned} b(nT_s) &= +\delta & \text{if } x(nT_s) &\geq \hat{x}(nT_s) \\ &= -\delta & \text{if } x(nT_s) &< \hat{x}(nT_s) \end{aligned} \quad \dots (4)$$

If  $b(nT_s) = +\delta$ ; binary '1' is transmitted

and if  $b(nT_s) = -\delta$ ; binary '0' is transmitted.

$T_s$  = Sampling interval.

### DM Transmitter

Fig. (a) shows the transmitter based on equations 3 to 5.

The summer in the accumulator adds quantizer output ( $\pm\delta$ ) with the previous sample approximation. This gives present sample approximation. i.e.,

$$\begin{aligned} u(nT_s) &= u(nT_s - T_s) + [\pm\delta] \quad \text{or} \\ &= u[(n-1)T_s] + b(nT_s) \quad \dots (5) \end{aligned}$$

The previous sample approximation  $u[(n-1)T_s]$  is restored by delaying one sample period  $T_s$ . The sampled input signal  $x(nT_s)$  and staircase approximated signal  $\hat{x}(nT_s)$  are subtracted to get error signal  $e(nT_s)$ .

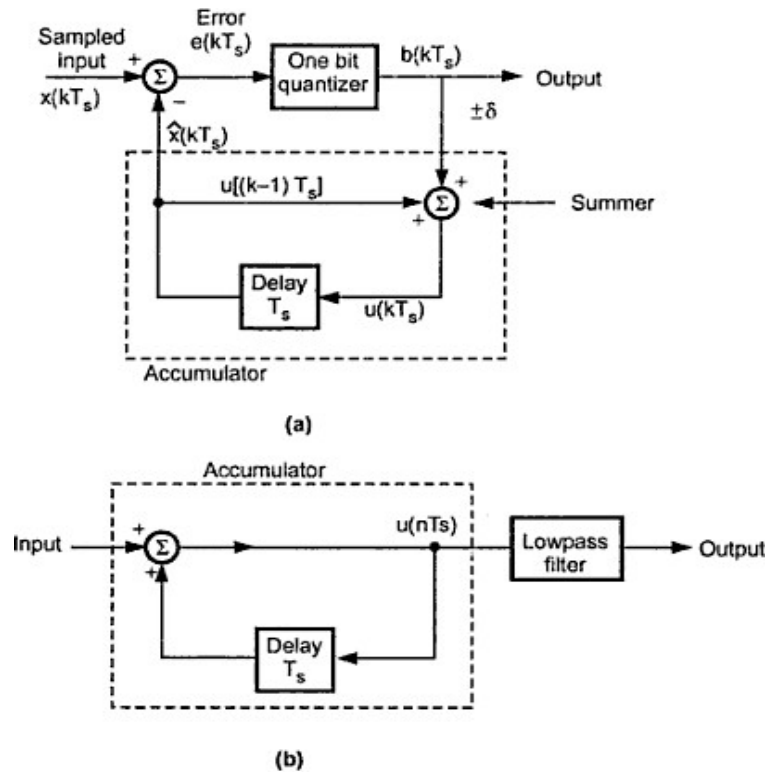

Fig. (a) Delta modulation transmitter and (b) Delta modulation receiver

Depending on the sign of  $e(nT_s)$  one bit quantizer produces an output step of  $+\delta$  or  $-\delta$ . If the step size is  $+\delta$ , then binary '1' is transmitted and if it is  $-\delta$ , then binary '0' is transmitted.

### DM Receiver

At the receiver shown in Fig. (b), the accumulator and low-pass filter are used. The accumulator generates the staircase approximated signal output and is delayed by one sampling period  $T_s$ . It is then added to the input signal. If input is binary '1' then it adds  $+\delta$  step to the previous output (which is delayed). If input is binary '0' then one step ' $\delta$ ' is subtracted from the delayed signal. The low-pass filter has the cutoff frequency equal to highest frequency in  $x(t)$ . This filter smoothen the staircase signal to reconstruct  $x(t)$ .

## Advantages and Disadvantages of Delta Modulation

### Advantages of Delta Modulation

The delta modulation has following advantages over PCM,

1. Delta modulation transmits only one bit for one sample. Thus the signaling rate and transmission channel bandwidth is quite small for delta modulation.
2. The transmitter and receiver implementation is very much simple for delta modulation. There is no analog to digital converter involved in delta modulation.

### Disadvantages of Delta Modulation

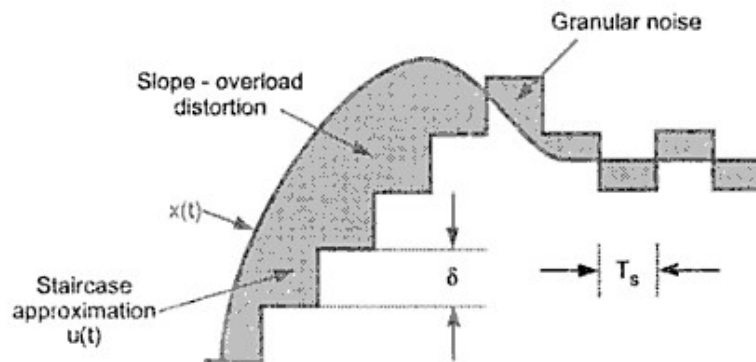

Fig. Quantization errors in delta modulation

The delta modulation has two drawbacks -

### **Slope Overload Distortion (Startup Error)**

This distortion arises because of the large dynamic range of the input signal.

As can be seen from Fig. the rate of rise of input signal  $x(t)$  is so high that the staircase signal cannot approximate it, the step size ' $\delta$ ' becomes too small for staircase signal  $u(t)$  to follow the steep segment of  $x(t)$ . Thus there is a large error between the staircase approximated signal and the original input signal  $x(t)$ . This error is called *slope overload distortion*. To reduce this error, the step size should be increased when slope of signal of  $x(t)$  is high.

Since the step size of delta modulator remains fixed, its maximum or minimum slopes occur along straight lines. Therefore this modulator is also called Linear Delta Modulator (LDM).

### **Granular Noise (Hunting)**

Granular noise occurs when the step size is too large compared to small variations in the input signal. That is for very small variations in the input signal, the staircase

signal is changed by large amount ( $\delta$ ) because of large step size. Fig shows that when the input signal is almost flat, the staircase signal  $u(t)$  keeps on oscillating by  $\pm\delta$  around the signal. The error between the input and approximated signal is called *granular noise*. The solution to this problem is to make step size small.

Thus large step size is required to accommodate wide dynamic range of the input signal (to reduce slope overload distortion) and small steps are required to reduce granular noise. Adaptive delta modulation is the modification to overcome these errors.

## **Adaptive Delta Modulation**

### **Operating Principle**

To overcome the quantization errors due to slope overload and granular noise, the step size ( $\delta$ ) is made adaptive to variations in the input signal  $x(t)$ . Particularly in the steep segment of the signal  $x(t)$ , the step size is increased. When the input is varying slowly, the step size is reduced. Then the method is called *Adaptive Delta Modulation (ADM)*.

The adaptive delta modulators can take continuous changes in step size or discrete changes in step size.

### **Transmitter and Receiver**

Fig. (a) shows the transmitter and (b) shows receiver of adaptive delta modulator. The logic for step size control is added in the diagram. The step size increases or decreases according to certain rule depending on one bit quantizer output.

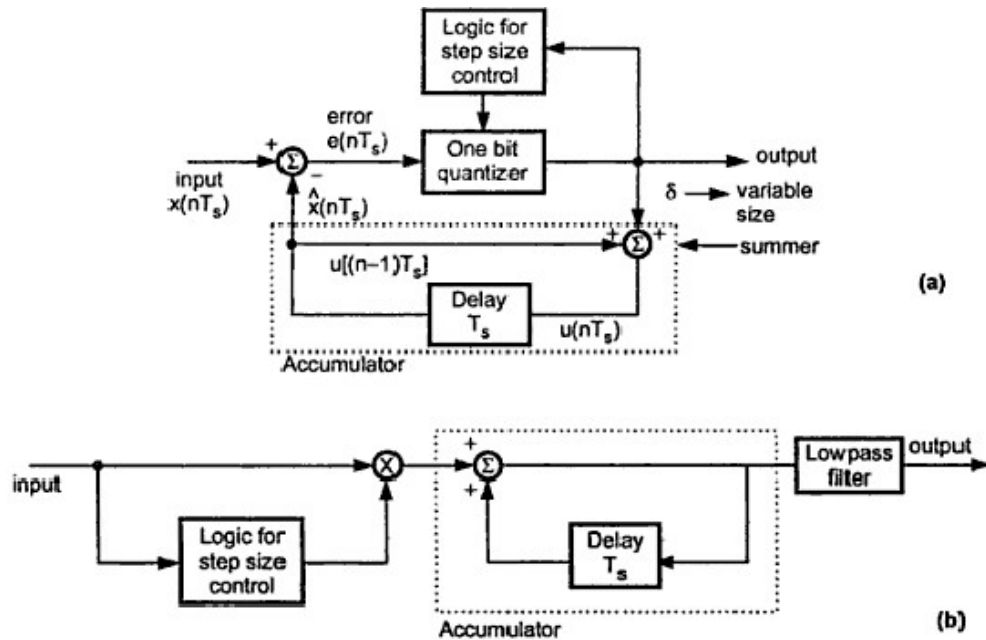

Fig. Adaptive delta modulator (a) Transmitter (b) Receiver

For example if one bit quantizer output is high (1), then step size may be doubled for next sample. If one bit quantizer output is low, then step size may be reduced by one step. Fig. shows the waveforms of adaptive delta modulator and sequence of bits transmitted.

In the receiver of adaptive delta modulator shown in Fig. (b) the first part generates the step size from each incoming bit. Exactly the same process is followed as that in transmitter. The previous input and present input decides the step size. It is then given to an accumulator which builds up staircase waveform. The low-pass filter then smoothens out the staircase waveform to reconstruct the smooth signal.

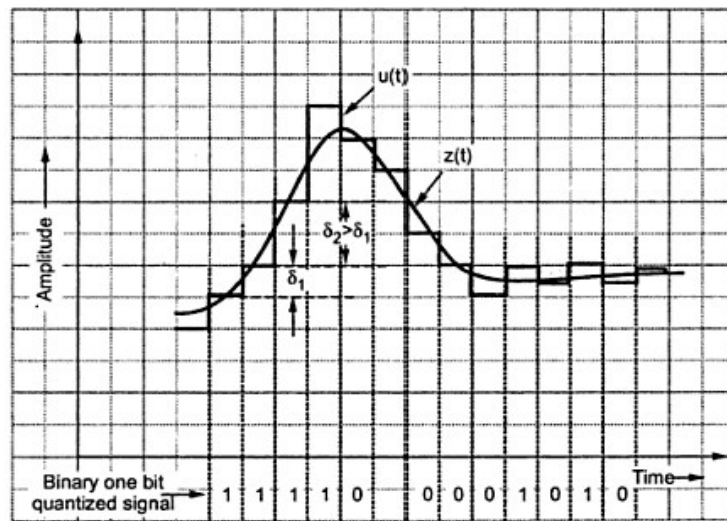

Fig. Waveforms of adaptive delta modulation

### Advantages of Adaptive Delta Modulation

Adaptive delta modulation has certain advantages over delta modulation. i.e.,

1. The signal to noise ratio is better than ordinary delta modulation because of the reduction in slope overload distortion and granular noise.
2. Because of the variable step size, the dynamic range of ADM is wide.
3. Utilization of bandwidth is better than delta modulation.

Plus other advantages of delta modulation are, only one bit per sample is required and simplicity of implementation of transmitter and receiver.

### Condition for Slope overload distortion occurrence:

Slope overload distortion will occur if

$$A_m > \frac{\delta}{2\pi f_m T_s}$$

where  $T_s$  is the sampling period.

Let the sine wave be represented as,

$$x(t) = A_m \sin(2\pi f_m t)$$

Slope of  $x(t)$  will be maximum when derivative of  $x(t)$  with respect to 't' will be maximum. The maximum slope of delta modulator is given

$$\begin{aligned} \text{Max. slope} &= \frac{\text{Step size}}{\text{Sampling period}} \\ &= \frac{\delta}{T_s} \end{aligned} \quad \dots\dots\dots(1)$$

Slope overload distortion will take place if slope of sine wave is greater than slope of delta modulator i.e.

$$\max \left| \frac{d}{dt} x(t) \right| > \frac{\delta}{T_s}$$

$$\max \left| \frac{d}{dt} A_m \sin(2\pi f_m t) \right| > \frac{\delta}{T_s}$$

$$\max |A_m 2\pi f_m \cos(2\pi f_m t)| > \frac{\delta}{T_s}$$

$$A_m 2\pi f_m > \frac{\delta}{T_s}$$

or  $A_m > \frac{\delta}{2\pi f_m T_s}$  \dots\dots\dots(2)

**Expression for Signal to Quantization Noise power ratio for Delta Modulation:**

To obtain signal power :

slope overload distortion will not occur if

$$A_m \leq \frac{\delta}{2\pi f_m T_s}$$

Here  $A_m$  is peak amplitude of sinusoidal signal

$\delta$  is the step size

$f_m$  is the signal frequency and

$T_s$  is the sampling period.

From above equation, the maximum signal amplitude will be,

$$A_m = \frac{\delta}{2\pi f_m T_s} \dots\dots\dots(1)$$

Signal power is given as,

$$P = \frac{V^2}{R}$$

Here V is the rms value of the signal. Here  $V = \frac{A_m}{\sqrt{2}}$ . Hence above equation

becomes,

$$P = \left( \frac{A_m}{\sqrt{2}} \right)^2 / R$$

Normalized signal power is obtained by taking  $R = 1$ . Hence,

$$P = \frac{A_m^2}{2}$$

Putting for  $A_m$  from equation 1

$$P = \frac{\delta^2}{8\pi^2 f_m^2 T_s^2} \dots\dots\dots(2)$$

This is an expression for signal power in delta modulation.

(ii) To obtain noise power

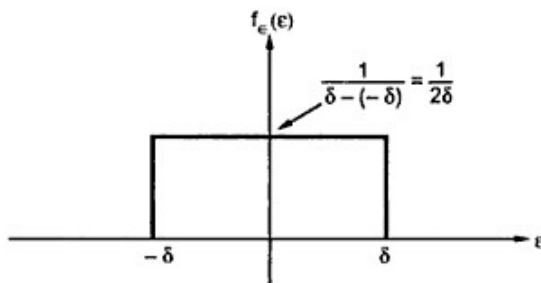

Fig. Uniform distribution of quantization error

We know that the maximum quantization error in delta modulation is equal to step size ' $\delta$ '. Let the quantization error be uniformly distributed over an interval  $[-\delta, \delta]$ . This is shown in Fig. From this figure the PDF of quantization error can be expressed as,

$$f_{\epsilon}(\epsilon) = \begin{cases} 0 & \text{for } \epsilon < -\delta \\ \frac{1}{2\delta} & \text{for } -\delta < \epsilon < \delta \\ 0 & \text{for } \epsilon > \delta \end{cases} \dots\dots\dots(3)$$

The noise power is given as,

$$\text{Noise power} = \frac{V_{\text{noise}}^2}{R}$$

Here  $V_{\text{noise}}^2$  is the mean square value of noise voltage. Since noise is defined by random variable 'e' and PDF  $f_{\epsilon}(\epsilon)$ , its mean square value is given as,

$$\text{mean square value} = E[\epsilon^2] = \overline{\epsilon^2}$$

mean square value is given as,

$$E[\epsilon^2] = \int_{-\infty}^{\infty} \epsilon^2 f_{\epsilon}(\epsilon) d\epsilon$$

From equation 3

$$\begin{aligned} E[\epsilon^2] &= \int_{-\delta}^{\delta} \epsilon^2 \cdot \frac{1}{2\delta} d\epsilon \\ &= \frac{1}{2\delta} \left[ \frac{\epsilon^3}{3} \right]_{-\delta}^{\delta} \\ &= \frac{1}{2\delta} \left[ \frac{\delta^3}{3} + \frac{\delta^3}{3} \right] = \frac{\delta^2}{3} \dots\dots\dots(4) \end{aligned}$$

Hence noise power will be,

$$\text{noise power} = \left( \frac{\delta^2}{3} \right) / R$$

Normalized noise power can be obtained with  $R = 1$ . Hence,

$$\text{noise power} = \frac{\delta^2}{3} \dots\dots\dots(5)$$



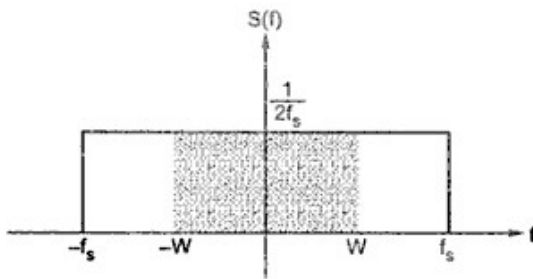

Fig. PSD of noise

This noise power is uniformly distributed over  $-f_s$  to  $f_s$  range. This is illustrated in Fig. At the output of delta modulator receiver there is lowpass reconstruction filter whose cutoff frequency is 'W'. This cutoff frequency is equal to highest signal frequency. The reconstruction filter passes part of the noise power at the output as Fig. From the geometry of Fig. output noise power will be,

$$\text{Output noise power} = \frac{W}{f_s} \times \text{noise power} = \frac{W}{f_s} \times \frac{\delta^2}{3}$$

We know that  $f_s = \frac{1}{T_s}$ , hence above equation becomes,

$$\text{Output noise power} = \frac{WT_s \delta^2}{3} \dots\dots\dots(6)$$

**(iii) To obtain signal to noise power ratio**

Signal to noise power ratio at the output of delta modulation receiver is given as,

$$\frac{S}{N} = \frac{\text{Normalized signal power}}{\text{Normalized noise power}}$$

From equation 2. and equation 6

$$\frac{S}{N} = \frac{\delta^2}{\frac{8\pi^2 f_m^2 T_s^2}{WT_s \delta^2}}$$

$$\boxed{\frac{S}{N} = \frac{3}{8\pi^2 W f_m^2 T_s^3}} \dots\dots\dots(7)$$

This is an expression for signal to noise power ratio in delta modulation.

## UNIT-2

### DIGITAL MODULATION TECHNIQUES

Digital Modulation provides more information capacity, high data security, quicker system availability with great quality communication. Hence, digital modulation techniques have a greater demand, for their capacity to convey larger amounts of data than analog ones.

There are many types of digital modulation techniques and we can even use a combination of these techniques as well. In this chapter, we will be discussing the most prominent digital modulation techniques.

if the information signal is digital and the amplitude ( $V$ ) of the carrier is varied proportional to the information signal, a digitally modulated signal called amplitude shift keying (ASK) is produced.

If the frequency ( $f$ ) is varied proportional to the information signal, frequency shift keying (FSK) is produced, and if the phase of the carrier ( $\theta$ ) is varied proportional to the information signal, phase shift keying (PSK) is produced. If both the amplitude and the phase are varied proportional to the information signal, quadrature amplitude modulation (QAM) results. ASK, FSK, PSK, and QAM are all forms of digital modulation:

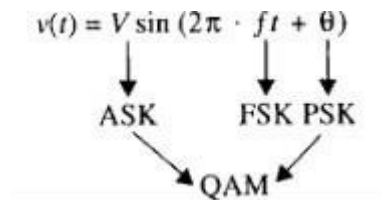

a simplified block diagram for a digital modulation system.

#### Amplitude Shift Keying

The amplitude of the resultant output depends upon the input data whether it should be a zero level or a variation of positive and negative, depending upon the carrier frequency.

**Amplitude Shift Keying (ASK)** is a type of Amplitude Modulation which represents the binary data in the form of variations in the amplitude of a signal.

Following is the diagram for ASK modulated waveform along with its input.

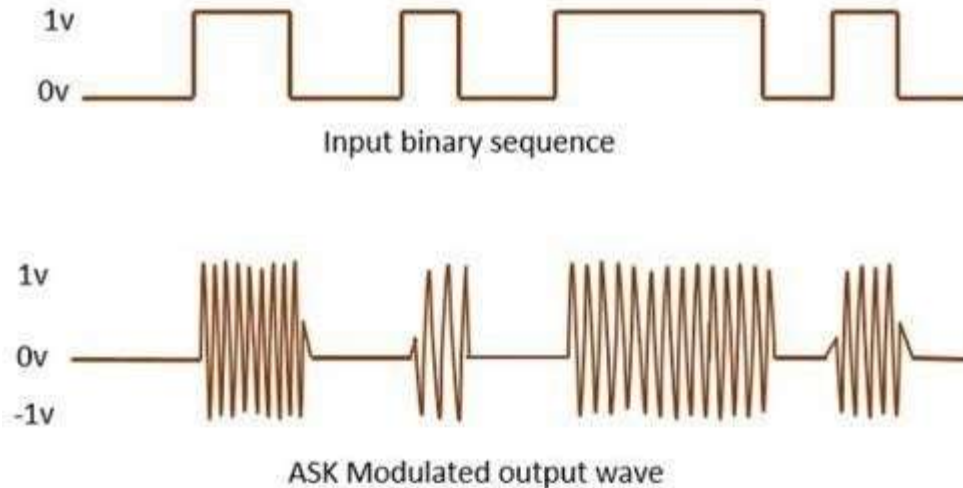

Any modulated signal has a high frequency carrier. The binary signal when ASK is modulated, gives a zero value for LOW input and gives the carrier output for HIGH input. Mathematically, amplitude-shift keying is

$$v_{(ask)}(t) = [1 + v_m(t)] \left[ \frac{A}{2} \cos(\omega_c t) \right]$$

where  $v_{ask}(t)$  = amplitude-shift keying wave

$v_m(t)$  = digital information (modulating) signal (volts)

$A/2$  = unmodulated carrier amplitude (volts)

$\omega_c$  = analog carrier radian frequency (radians per second,  $2\pi f_c t$ )

In above Equation, the modulating signal [ $v_m(t)$ ] is a normalized binary waveform, where + 1 V = logic 1 and -1 V = logic 0. Therefore, for a logic 1 input,  $v_m(t) = + 1$  V, Equation 2.12 reduces to

$$\begin{aligned} v_{(ask)}(t) &= [1 + 1] \left[ \frac{A}{2} \cos(\omega_c t) \right] \\ &= \underline{A \cos(\omega_c t)} \end{aligned}$$

Mathematically, amplitude-shift keying is (2.12) where  $v_{ask}(t)$  = amplitude-shift keying wave

$v_m(t)$  = digital information (modulating) signal (volts)  $A/2$  = unmodulated carrier amplitude (volts)

$\omega_c$  = analog carrier radian frequency (radians per second,  $2\pi f_c t$ ) In Equation 2.12, the modulating signal  $[v_m(t)]$  is a normalized binary waveform, where  $+1 \text{ V} = \text{logic 1}$  and  $-1 \text{ V} = \text{logic 0}$ . Therefore, for a logic 1 input,  $v_m(t) = +1 \text{ V}$ , Equation 2.12 reduces to and for a logic 0 input,  $v_m(t) = -1 \text{ V}$ , Equation reduces to

$$v_{(ask)}(t) = [1 - 1] \left[ \frac{A}{2} \cos(\omega_c t) \right]$$

Thus, the modulated wave  $v_{ask}(t)$ , is either  $A \cos(\omega_c t)$  or 0. Hence, the carrier is either "on" or "off," which is why amplitude-shift keying is sometimes referred to as on-off keying (OOK).

it can be seen that for every change in the input binary data stream, there is one change in the ASK waveform, and the time of one bit ( $t_b$ ) equals the time of one analog signaling element ( $t_s$ ).

$$B = f_b / 1 = f_b \quad \text{baud} = f_b / 1 = f_b$$

**Example :**

Determine the baud and minimum bandwidth necessary to pass a 10 kbps binary signal using amplitude shift keying. 10Solution For ASK,  $N = 1$ , and the baud and minimum bandwidth are determined from Equations 2.11 and 2.10, respectively:

$$B = 10,000 / 1 = 10,000$$

$$\text{baud} = 10,000 / 1 = 10,000$$

The use of amplitude-modulated analog carriers to transport digital information is a relatively low-quality, low-cost type of digital modulation and, therefore, is seldom used except for very low-speed telemetry circuits.

**ASK TRANSMITTER:**

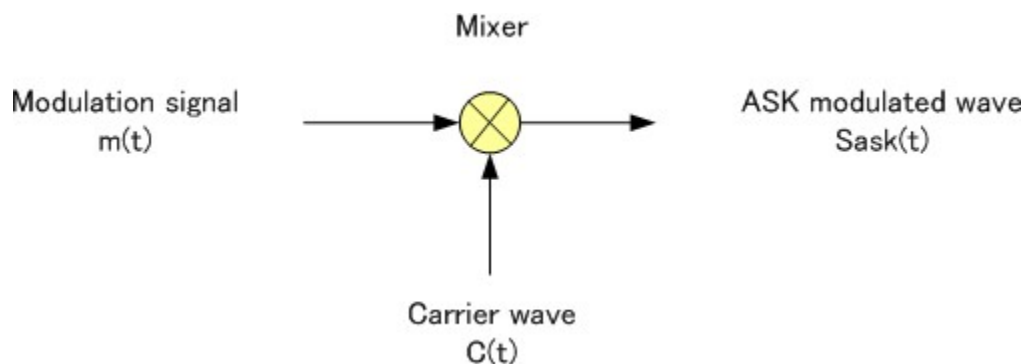

The input binary sequence is applied to the product modulator. The product modulator amplitude modulates the sinusoidal carrier .it passes the carrier when input bit is '1' .it blocks the carrier when input bit is '0.'

### Coherent ASK DETECTOR:

### FREQUENCYSHIFT KEYING

The frequency of the output signal will be either high or low, depending upon the input data applied.

**Frequency Shift Keying (FSK)** is the digital modulation technique in which the frequency of the carrier signal varies according to the discrete digital changes. FSK is a scheme of frequency modulation.

Following is the diagram for FSK modulated waveform along with its input.

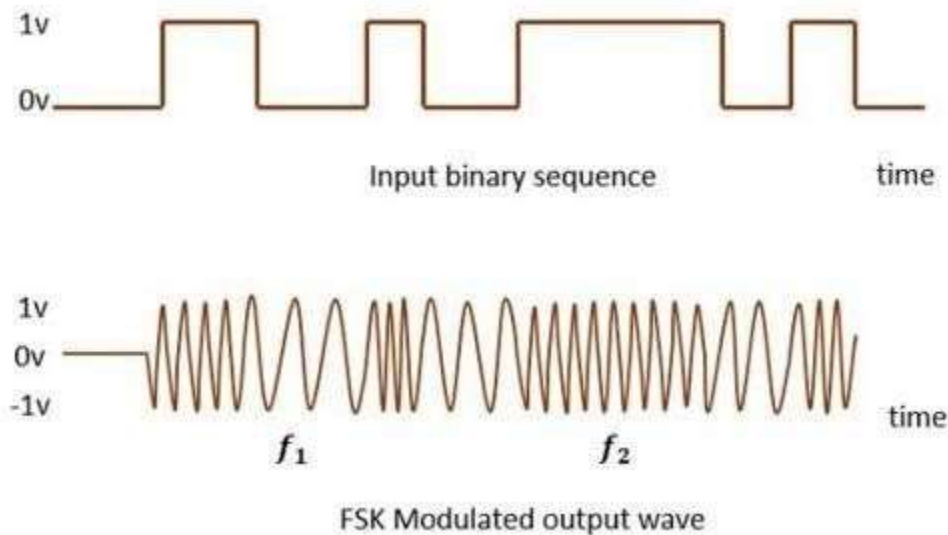

The output of a FSK modulated wave is high in frequency for a binary HIGH input and is low in frequency for a binary LOW input. The binary 1s and 0s are called **Mark** and **Space frequencies**.

FSK is a form of constant-amplitude angle modulation similar to standard frequency modulation (FM) except the modulating signal is a binary signal that varies between two discrete voltage levels rather than a continuously changing analog waveform. Consequently, FSK is sometimes called *binary FSK* (BFSK). The general expression for FSK is

where

$$v_{fsk}(t) = V_c \cos\{2\pi[f_c + v_m(t) \Delta f]t\}$$

$v_{fsk}(t)$  = binary FSK waveform

$V_c$  = peak analog carrier amplitude (volts)

$f_c$  = analog carrier center frequency(hertz)

$\Delta f$  = peak change (shift)in the analog carrier frequency(hertz)

$v_m(t)$  = binary input (modulating) signal (volts)

From Equation 2.13, it can be seen that the peak shift in the carrier frequency (  $\Delta f$  ) is proportional to the amplitude of the binary input signal (  $v_m[t]$  ), and the direction of the shift is determined by the polarity.

The modulating signal is a normalized binary waveform where a logic 1 = + 1 V and a logic 0 = -1

V. Thus, for a logic 1 input,  $v_m(t) = + 1$ , Equation 2.13 can be rewritten as

$$v_{fsk}(t) = V_c \cos[2\pi(f_c + \Delta f)t]$$

For a logic 0 input,  $v_m(t) = -1$ , Equation becomes

$$v_{fsk}(t) = V_c \cos[2\pi(f_c - \Delta f)t]$$

With binary FSK, the carrier center frequency (  $f_c$  ) is shifted (deviated) up and down in the frequency domain by the binary input signal as shown in Figure 2-3.

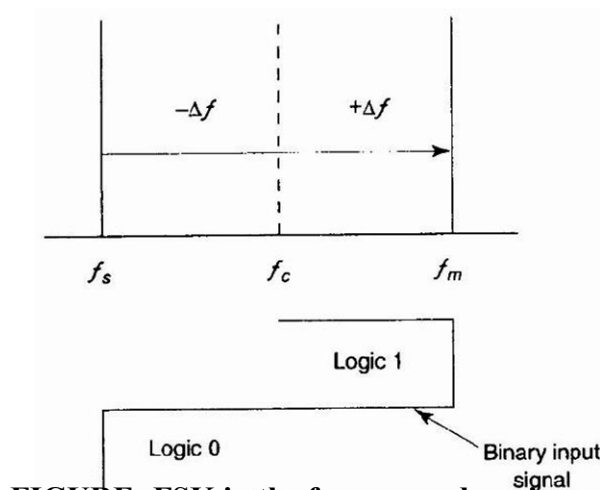

**FIGURE: FSK in the frequency domain**

As the binary input signal changes from a logic 0 to a logic 1 and vice versa, the output frequency shifts between two frequencies: a mark, or logic 1 frequency ( $f_m$ ), and a space, or logic 0 frequency ( $f_s$ ). The mark and space frequencies are separated from the carrier frequency by the peak frequency deviation ( $f$ ) and from each other by  $2f$ .

Frequency deviation is illustrated in Figure 2-3 and expressed mathematically as

$$f = |f_m - f_s| / 2 \quad (2.14)$$

where  $f$  = frequency deviation (hertz)

$|f_m - f_s|$  = absolute difference between the mark and space frequencies (hertz)

Figure 2-4a shows in the time domain the binary input to an FSK modulator and the corresponding FSK output.

When the binary input ( $f_b$ ) changes from a logic 1 to a logic 0 and vice versa, the FSK output frequency shifts from a mark ( $f_m$ ) to a space ( $f_s$ ) frequency and vice versa.

In Figure 2-4a, the mark frequency is the higher frequency ( $f_c + f$ ) and the space frequency is the lower frequency ( $f_c - f$ ), although this relationship could be just the opposite.

Figure 2-4b shows the truth table for a binary FSK modulator. The truth table shows the input and output possibilities for a given digital modulation scheme.

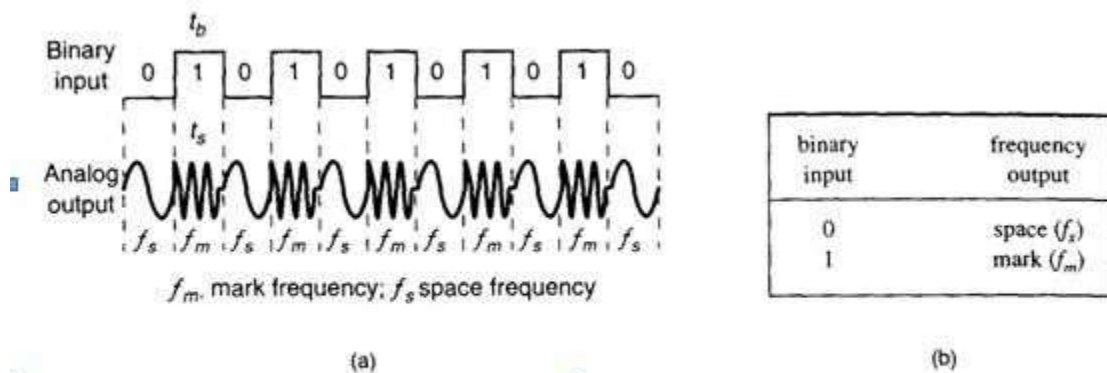

FIGURE 2-4 FSK in the time domain: (a) waveform: (b) truth table

## FSK Bit Rate, Baud, and Bandwidth

In Figure 2-4a, it can be seen that the time of one bit ( $t_b$ ) is the same as the time the FSK output is a mark or space frequency ( $t_s$ ). Thus, the bit time equals the time of an FSK signaling element, and the bit rate equals the baud.

The baud for binary FSK can also be determined by substituting  $N = 1$  in Equation 2.11:

$$\text{baud} = f_b / 1 = f_b$$

The minimum bandwidth for FSK is given as

$$B = |(f_s - f_b) - (f_m - f_b)|$$

$$= |(f_s - f_m)| + 2f_b$$

and since  $|(f_s - f_m)|$  equals  $2f$ , the minimum bandwidth can be approximated as

$$B = 2(f + f_b) \quad (2.15)$$

where

$B$  = minimum Nyquist bandwidth (hertz)

$f$  = frequency deviation  $|(f_m - f_s)|$  (hertz)

$f_b$  = input bit rate (bps)

### Example 2-2

Determine (a) the peak frequency deviation, (b) minimum bandwidth, and (c) baud for a binary FSK signal with a mark frequency of 49 kHz, a space frequency of 51 kHz, and an input bit rate of 2 kbps.

### Solution

a. The peak frequency deviation is determined from Equation 2.14:

$$f = |149\text{kHz} - 51\text{kHz}| / 2 = 1\text{ kHz}$$

b. The minimum bandwidth is determined from Equation 2.15:

$$\begin{aligned} B &= 2(100 + 2000) \\ &= 6\text{ kHz} \end{aligned}$$



c. For FSK,  $N = 1$ , and the baud is determined from Equation 2.11 as

$$\text{baud} = 2000 / 1 = 2000$$

### FSK TRANSMITTER:

Figure 2-6 shows a simplified binary FSK modulator, which is very similar to a conventional FM modulator and is very often a voltage-controlled oscillator (VCO). The center frequency ( $f_c$ ) is chosen such that it falls halfway between the mark and space frequencies.

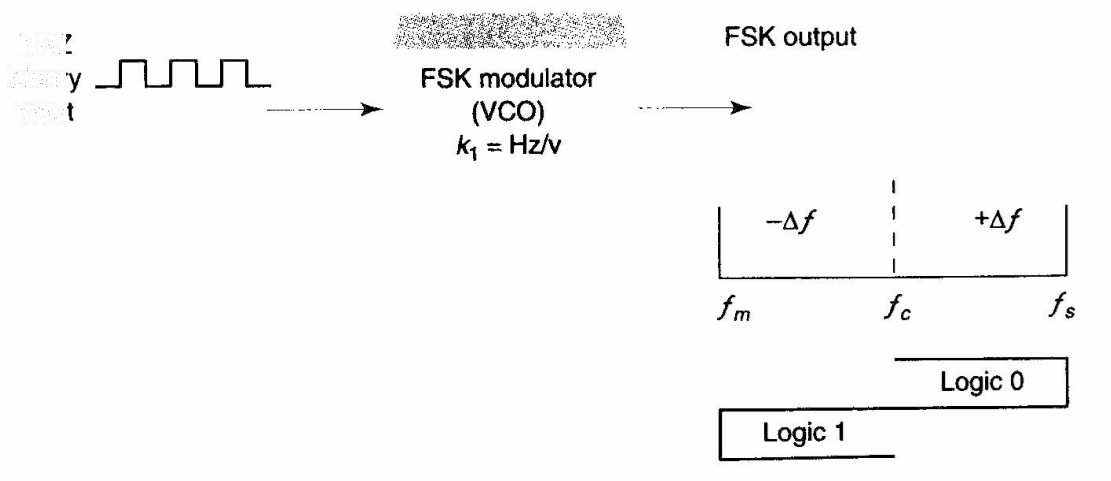

A logic 1 input shifts the VCO output to the mark frequency, and a logic 0 input shifts the VCO output to the space frequency. Consequently, as the binary input signal changes back and forth between logic 1 and logic 0 conditions, the VCO output shifts or deviates back and forth between the mark and space frequencies.

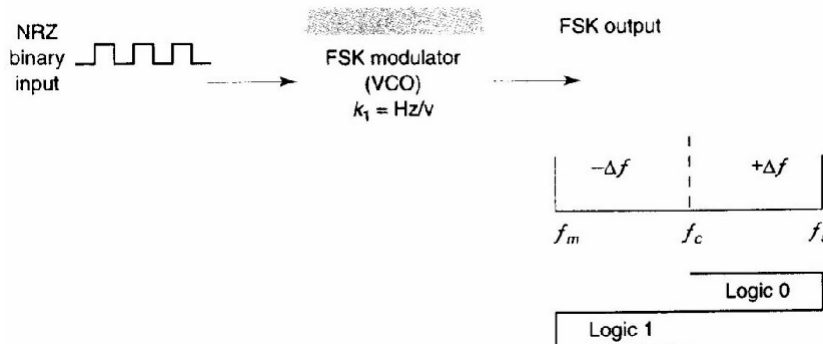

**FIGURE 2-6 FSK modulator**

A VCO-FSK modulator can be operated in the sweep mode where the peak frequency deviation is simply the product of the binary input voltage and the deviation sensitivity of the VCO.

With the sweep mode of modulation, the frequency deviation is expressed mathematically as

$$f = v_m(t)k_f \quad (2-19)$$

$v_m(t)$  = peak binary modulating-signal voltage (volts)

$k_f$  = deviation sensitivity (hertz per volt).

### FSK Receiver

FSK demodulation is quite simple with a circuit such as the one shown in Figure 2-7.

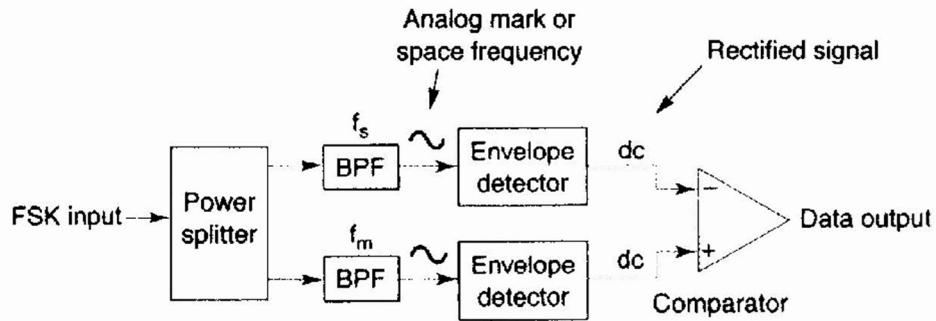
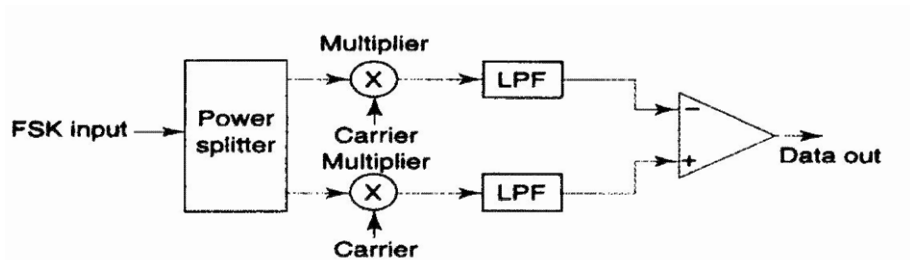

**FIGURE 2-7 Noncoherent FSK demodulator**

The FSK input signal is simultaneously applied to the inputs of both bandpass filters (BPFs) through a power splitter. The respective filter passes only the mark or only the space frequency on to its respective envelope detector. The envelope detectors, in turn, indicate the total power in each passband, and the comparator responds to the largest of the two powers. This type of FSK detection is referred to as noncoherent detection.

Figure 2-8 shows the block diagram for a coherent FSK receiver. The incoming FSK signal is multiplied by a recovered carrier signal that has the exact same frequency and phase as the transmitter reference.

However, the two transmitted frequencies (the mark and space frequencies) are not generally continuous; it is not practical to reproduce a local reference that is coherent with both of them. Consequently, coherent FSK detection is seldom used.



**FIGURE 2-8 Coherent FSK demodulator**

## PHASESHIFT KEYING:

The phase of the output signal gets shifted depending upon the input. These are mainly of two types, namely BPSK and QPSK, according to the number of phase shifts. The other one is DPSK which changes the phase according to the previous value.

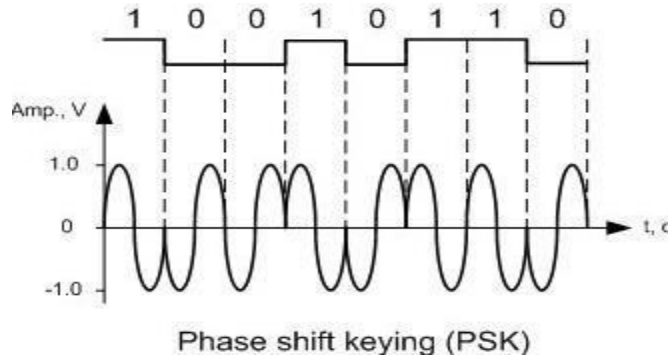

**Phase Shift Keying (PSK)** is the digital modulation technique in which the phase of the carrier signal is changed by varying the sine and cosine inputs at a particular time. PSK technique is widely used for wireless LANs, bio-metric, contactless operations, along with RFID and Bluetooth communications.

PSK is of two types, depending upon the phases the signal gets shifted. They are –

Binary Phase Shift Keying (BPSK)

This is also called as **2-phase PSK** (or) **Phase Reversal Keying**. In this technique, the sine wave carrier takes two phase reversals such as  $0^\circ$  and  $180^\circ$ .

BPSK is basically a DSB-SC (Double Sideband Suppressed Carrier) modulation scheme, for message being the digital information.

Following is the image of BPSK Modulated output wave along with its input.

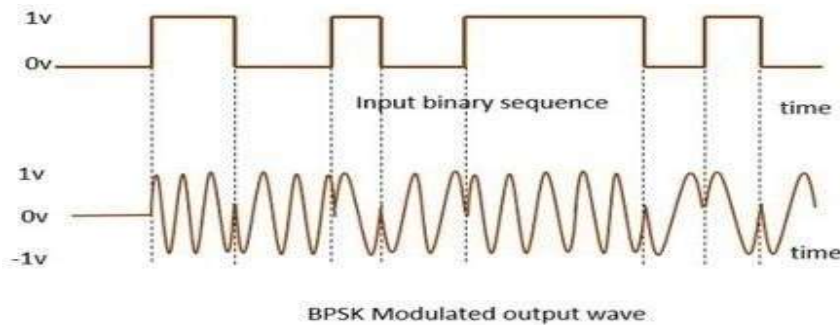

## Binary Phase-Shift Keying

The simplest form of PSK is *binary phase-shift keying* (BPSK), where  $N = 1$  and  $M = 2$ . Therefore, with BPSK, two phases ( $2^1 = 2$ ) are possible for the carrier. One phase represents a logic 1, and the other phase represents a logic 0. As the input digital signal changes state (i.e., from a 1 to a 0 or from a 0 to a 1), the phase of the output carrier shifts between two angles that are separated by  $180^\circ$ .

Hence, other names for BPSK are *phase reversal keying* (PRK) and *biphase modulation*. BPSK is a form of square-wave modulation of a *continuous wave (CW)* signal.

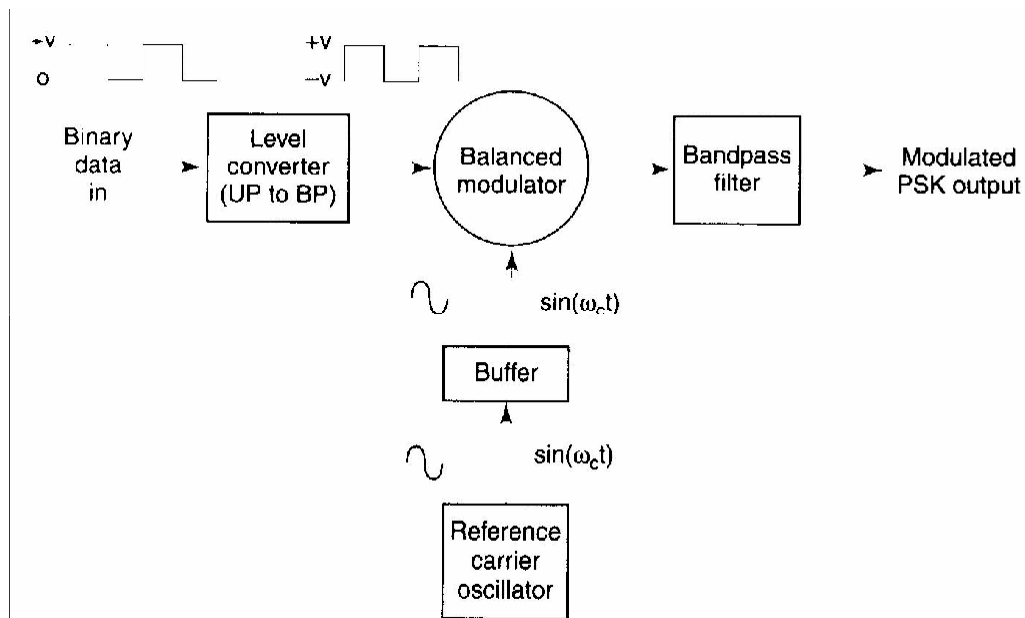

FIGURE 2-12 BPSK transmitter

### BPSK TRANSMITTER:

Figure 2-12 shows a simplified block diagram of a BPSK transmitter. The balanced modulator acts as a phase reversing switch. Depending on the logic condition of the digital input, the carrier is transferred to the output either in phase or  $180^\circ$  out of phase with the reference carrier oscillator.

Figure 2-13 shows the schematic diagram of a balanced ring modulator. The balanced modulator has two inputs: a carrier that is in phase with the reference oscillator and the binary digital data. For the balanced modulator to operate properly, the digital input voltage must be much greater than the peak carrier voltage.

This ensures that the digital input controls the on/off state of diodes D1 to D4. If the binary input is a logic 1 (positive voltage), diodes D1 and D2 are forward biased and on, while diodes D3 and D4

are reverse biased and off (Figure 2-13b). With the polarities shown, the carrier voltage is developed across transformer T2 in phase with the carrier voltage across T1

1. Consequently, the output signal is in phase with the reference oscillator.

If the binary input is a logic 0 (negative voltage), diodes D1 and D2 are reverse biased and off, while diodes D3 and D4 are forward biased and on (Figure 9-13c). As a result, the carrier voltage is developed across transformer T2 180° out of phase with the carrier voltage across T1.

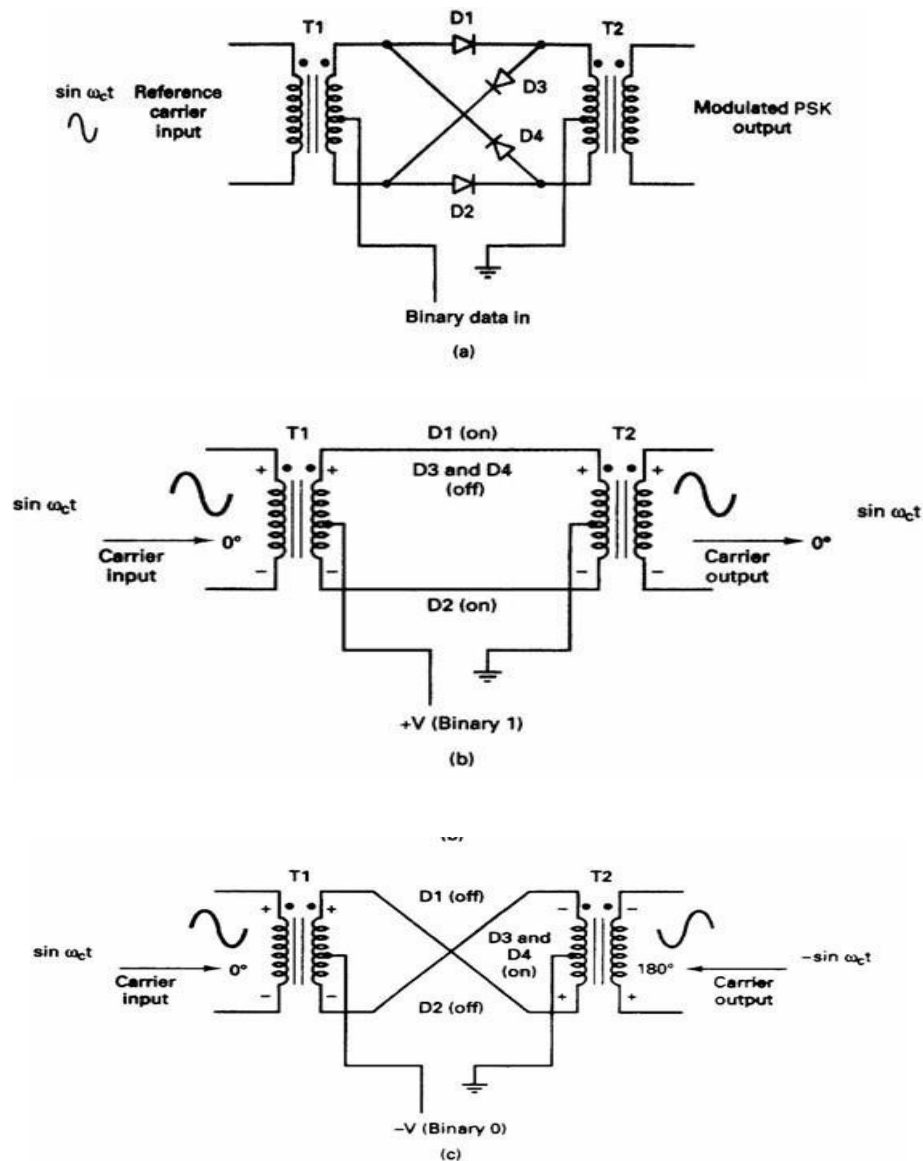

**FIGURE 9-13 (a) Balanced ring modulator; (b) logic 1 input; (c) logic 0 input**

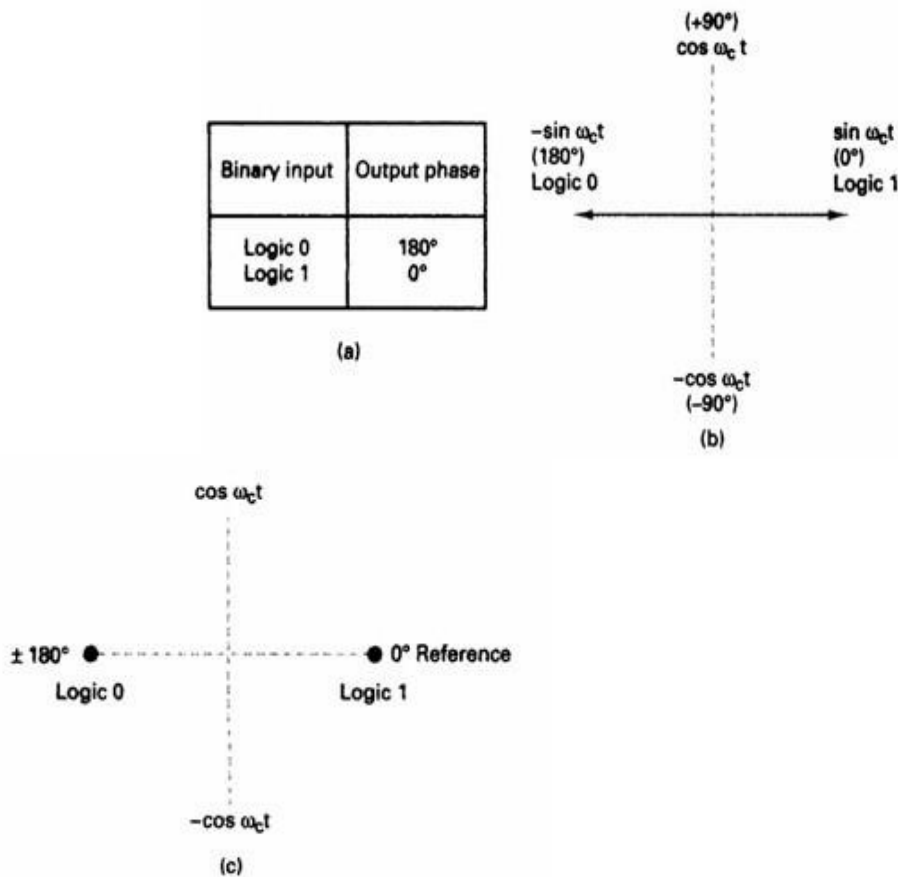

FIGURE 2-14 BPSK modulator: (a) truth table; (b) phasor diagram; (c) constellation diagram

### BANDWIDTH CONSIDERATIONS OF BPSK:

In a BPSK modulator, the carrier input signal is multiplied by the binary data.

If +1 V is assigned to a logic 1 and -1 V is assigned to a logic 0, the input carrier ( $\sin \omega_c t$ ) is multiplied by either a + or - 1.

The output signal is either  $+1 \sin \omega_c t$  or  $-1 \sin \omega_c t$  the first represents a signal that is *in phase* with the reference oscillator, the latter a signal that is 180° out of phase with the reference oscillator. Each time the input logic condition changes, the output phase changes.

Mathematically, the output of a BPSK modulator is proportional to

$$\text{BPSK output} = [\sin (2\pi f_a t)] \times [\sin (2\pi f_c t)] \quad (2.20)$$

where

$f_a$  = maximum fundamental frequency of binary input (hertz)

$f_c$  = reference carrier frequency (hertz)

Solving for the trig identity for the product of two sine functions,

$$0.5\cos[2\pi(f_c - f_a)t] - 0.5\cos[2\pi(f_c + f_a)t]$$

Thus, the minimum double-sided Nyquist bandwidth ( $B$ ) is

$$f_c + f_a \quad \text{or} \quad \frac{f_c + f_a}{2}$$

$$-(f_c + f_a) \quad \text{or} \quad \frac{-f_c + f_a}{2}$$

$$2f_a$$

and because  $f_a = f_b / 2$ , where  $f_b$  = input bit rate,

where  $B$  is the minimum double-sided Nyquist bandwidth.

Figure 2-15 shows the output phase-versus-time relationship for a BPSK waveform. Logic 1 input produces an analog output signal with a  $0^\circ$  phase angle, and a logic 0 input produces an analog output signal with a  $180^\circ$  phase angle.

As the binary input shifts between a logic 1 and a logic 0 condition and vice versa, the phase of the BPSK waveform shifts between  $0^\circ$  and  $180^\circ$ , respectively.

BPSK signaling element ( $t_s$ ) is equal to the time of one information bit ( $t_b$ ), which indicates that the bit rate equals the baud.

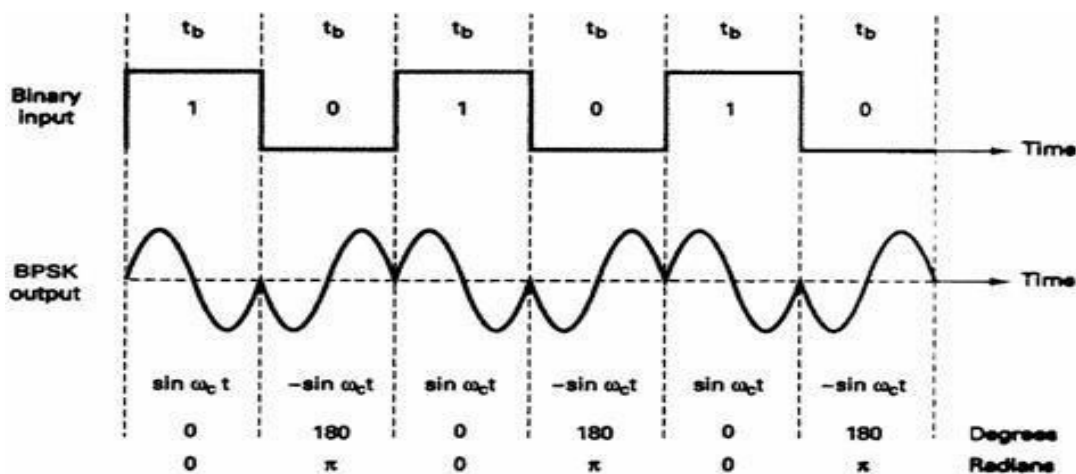

FIGURE 2-15 Output phase-versus-time relationship for a BPSK modulator

**Example:**

For a BPSK modulator with a carrier frequency of 70 MHz and an input bit rate of 10 Mbps, determine the maximum and minimum upper and lower side frequencies, draw the output spectrum, determine the minimum Nyquist bandwidth, and calculate the baud.

Solution

Substituting into Equation 2-20 yields

$$\begin{aligned} \text{output} &= [\sin(2\pi f_a t)] \times [\sin(2\pi f_c t)]; f_a = f_b / 2 = 5 \text{ MHz} \\ &= [\sin 2\pi(5\text{MHz})t] \times [\sin 2\pi(70\text{MHz})t] \\ &= 0.5\cos[2\pi(70\text{MHz} - 5\text{MHz})t] - 0.5\cos[2\pi(70\text{MHz} + 5\text{MHz})t] \\ &\qquad \text{lower side frequency} \qquad \qquad \text{upper side frequency} \end{aligned}$$

**Minimum lower side frequency (LSF):**

$$\text{LSF} = 70\text{MHz} - 5\text{MHz} = 65\text{MHz}$$

**Maximum upper side frequency (USF):**

$$\text{USF} = 70 \text{ MHz} + 5 \text{ MHz} = 75 \text{ MHz}$$

Therefore, the output spectrum for the worst-case binary input conditions is as follows: The minimum Nyquist bandwidth (*B*) is

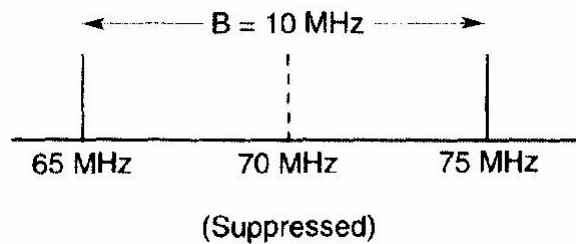

$$B = 75 \text{ MHz} - 65 \text{ MHz} = 10 \text{ MHz}$$

and the baud =  $f_b$  or 10 megabaud.

**BPSK receiver:**

Figure 2-16 shows the block diagram of a BPSK receiver.



The input signal maybe  $+\sin \omega_c t$  or  $-\sin \omega_c t$ . The coherent carrier recovery circuit detects and regenerates a carrier signal that is both frequency and phase coherent with the original transmit carrier.

The balanced modulator is a product detector; the output is the product of the two inputs (the BPSK signal and the recovered carrier).

The low-pass filter (LPF) operates the recovered binary data from the complex demodulated signal.

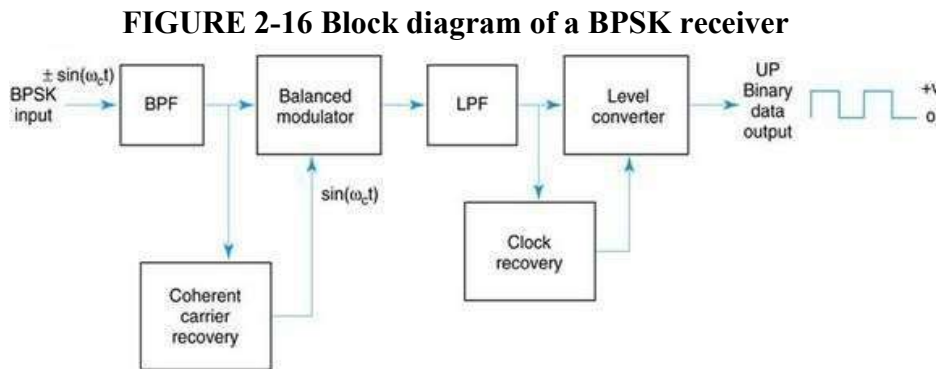

Mathematically, the demodulation process is as follows.

For a BPSK input signal of  $+\sin \omega_c t$  (logic 1), the output of the balanced modulator is

$$\text{output} = (\sin \omega_c t)(\sin \omega_c t) = \sin^2 \omega_c t \quad (2.21)$$

or

$$\sin^2 \omega_c t = 0.5(1 - \cos 2\omega_c t) = 0.5 - 0.5 \cos 2\omega_c t$$

↓  
filtered out

leaving output =  $+0.5 \text{ V} = \text{logic 1}$

It can be seen that the output of the balanced modulator contains a positive voltage ( $+1/2 \text{ V}$ ) and a cosine wave at twice the carrier frequency ( $2 \omega_c t$ ).

The LPF has a cutoff frequency much lower than  $2 \omega_c t$ , and, thus, blocks the second harmonic of the carrier and passes only the positive constant component. A positive voltage represents a demodulated logic 1.

For a BPSK input signal of  $-\sin \omega_c t$  (logic 0), the output of the balanced modulator is

$$\text{output} = (-\sin \omega_c t)(\sin \omega_c t) = -\sin^2 \omega_c t$$

or

$$\sin^2 \omega_c t = -0.5(1 - \cos 2\omega_c t) = 0.5 + 0.5 \cos 2\omega_c t$$

↓  
filtered out

leaving

output = - 0.5 V = logic 0

The output of the balanced modulator contains a negative voltage ( $-[1/2]V$ ) and a cosine wave at twice the carrier frequency ( $2\omega_c t$ ).

Again, the LPF blocks the second harmonic of the carrier and passes only the negative constant component. A negative voltage represents a demodulated logic 0.

### QUADRATURE PHASE SHIFT KEYING (QPSK):

This is the phase shift keying technique, in which the sine wave carrier takes four phase reversals such as  $0^\circ$ ,  $90^\circ$ ,  $180^\circ$ , and  $270^\circ$ .

If this kind of techniques are further extended, PSK can be done by eight or sixteen values also, depending upon the requirement. The following figure represents the QPSK waveform for two bits input, which shows the modulated result for different instances of binary inputs.

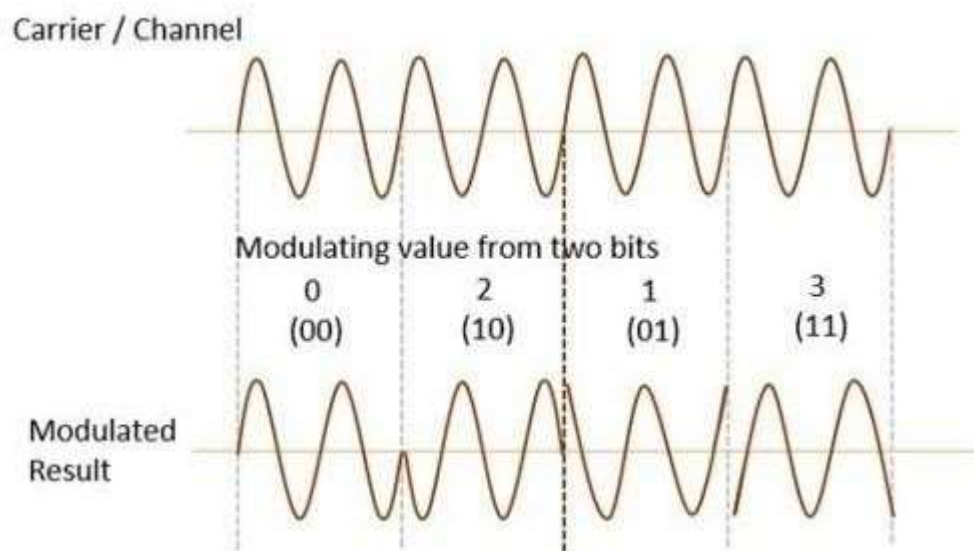

QPSK is a variation of BPSK, and it is also a DSB-SC (Double Sideband Suppressed Carrier) modulation scheme, which sends two bits of digital information at a time, called as **bigits**.

Instead of the conversion of digital bits into a series of digital stream, it converts them into bit-pairs.

This decreases the data bit rate to half, which allows space for the other users.

### QPSK transmitter.

A block diagram of a QPSK modulator is shown in Figure 2-17. Two bits (a dibit) are clocked into the bit splitter. After both bits have been serially inputted, they are simultaneously parallel outputted.

The I bit modulates a carrier that is in phase with the reference oscillator (hence the name "I" for "in phase" channel), and the Q bit modulate, a carrier that is 90° out of phase.

For a logic 1 = +1 V and a logic 0 = -1 V, two phases are possible at the output of the I balanced modulator ( $+\sin \omega_c t$  and  $-\sin \omega_c t$ ), and two phases are possible at the output of the Q balanced modulator ( $+\cos \omega_c t$ , and  $-\cos \omega_c t$ ).

When the linear summer combines the two quadrature (90° out of phase) signals, there are four possible resultant phasors given by these expressions:  $+\sin \omega_c t + \cos \omega_c t$ ,  $+\sin \omega_c t - \cos \omega_c t$ ,  $-\sin \omega_c t + \cos \omega_c t$ , and  $-\sin \omega_c t - \cos \omega_c t$ .

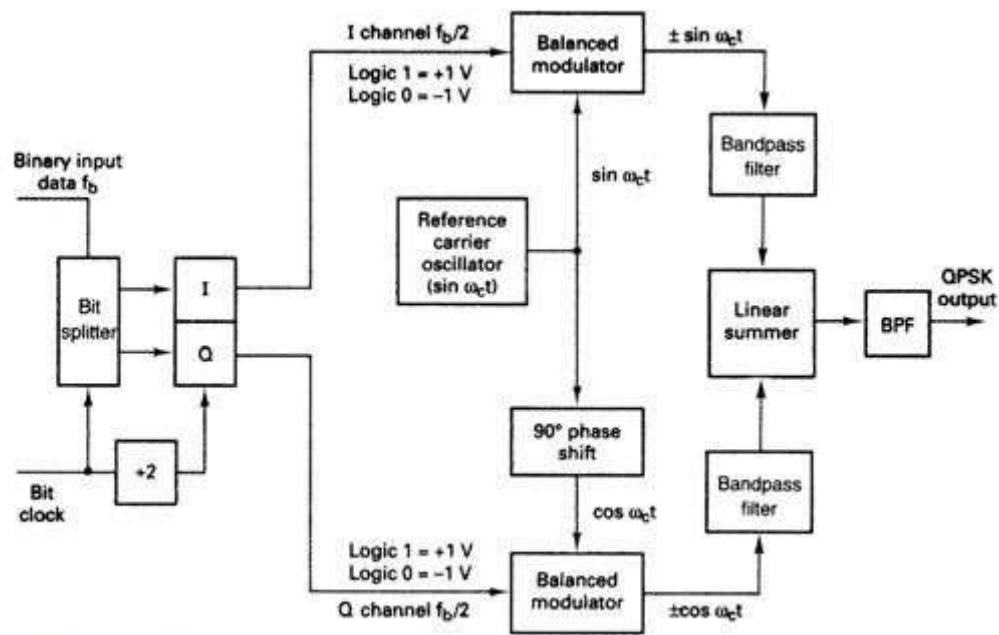

FIGURE 2-17 QPSK modulator

**Example:**

For the QPSK modulator shown in Figure 2-17, construct the truth table, phasor diagram, and constellation diagram.

**Solution**

For a binary data input of Q = 0 and I = 0, the two inputs to the I balanced modulator are -1 and  $\sin \omega_c t$ , and the two inputs to the Q balanced modulator are -1 and  $\cos \omega_c t$ .

Consequently, the outputs are

I balanced modulator  $=(-1)(\sin \omega_c t) = -1 \sin \omega_c t$

Q balanced modulator  $=(-1)(\cos \omega_c t) = -1 \cos \omega_c t$  and the output of the linear summer is  $-1 \cos \omega_c t - 1 \sin \omega_c t = 1.414 \sin(\omega_c t - 135^\circ)$

For the remaining dibit codes (01, 10, and 11), the procedure is the same. The results are shown in Figure 2-18a.

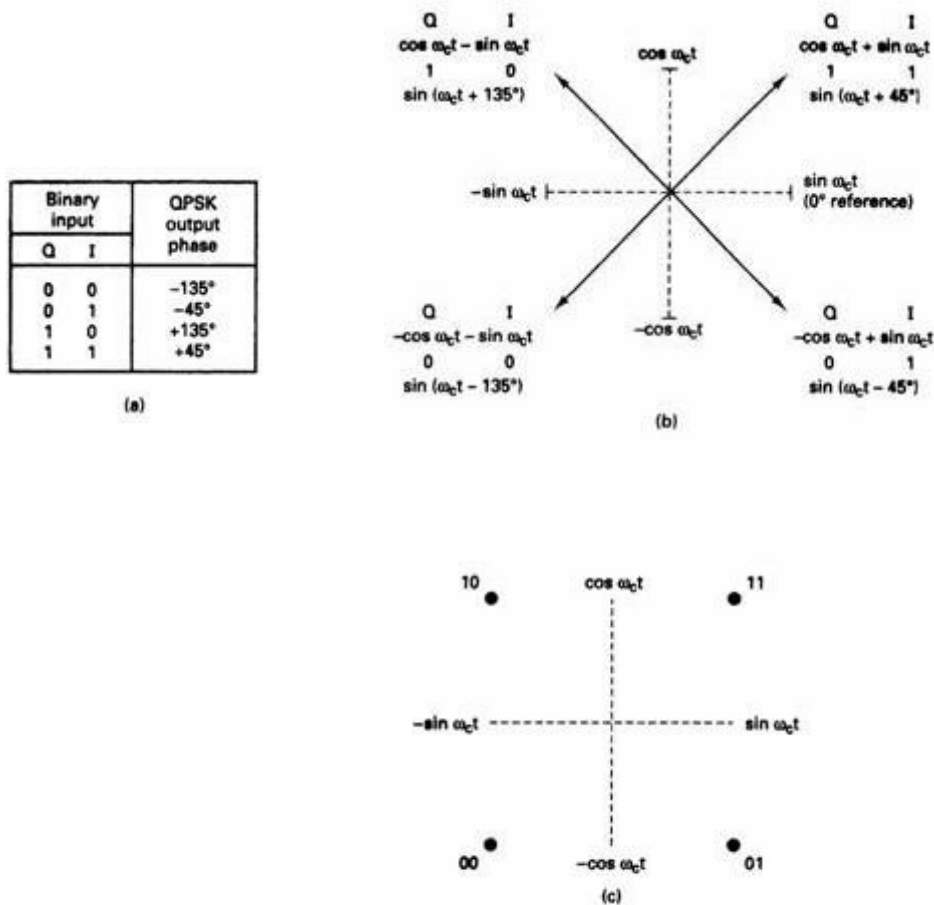
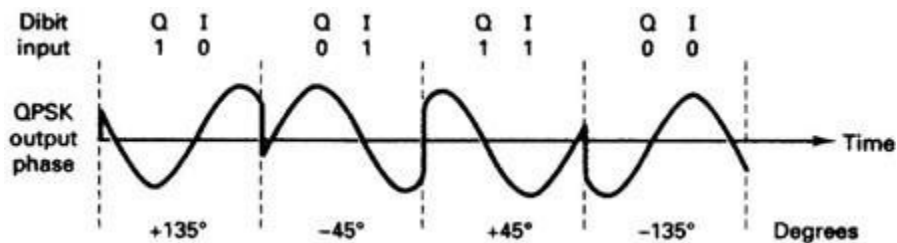

**FIGURE 2-18 QPSK modulator: (a) truth table; (b) phasor diagram; (c) constellation diagram**

In Figures 2-18b and c, it can be seen that with QPSK each of the four possible output phasors has exactly the same amplitude. Therefore, the binary information must be encoded entirely in the phase of the output signal

Figure 2-18b, it can be seen that the angular separation between any two adjacent phasors in QPSK is  $90^\circ$ . Therefore, a QPSK signal can undergo almost a  $+45^\circ$  or  $-45^\circ$  shift in phase during transmission and still retain the correct encoded information when demodulated at the receiver.

Figure 2-19 shows the output phase-versus-time relationship for a QPSK modulator.



**FIGURE 2-19 Output phase-versus-time relationship for a PSK modulator**

### **Bandwidth considerations of QPSK**

With QPSK, because the input data are divided into two channels, the bit rate in either the I or the Q channel is equal to one-half of the input data rate ( $f_b/2$ ) (one-half of  $f_b/2 = f_b/4$ ).

### **QPSK RECEIVER:**

The block diagram of a QPSK receiver is shown in Figure 2-21

The power splitter directs the input QPSK signal to the I and Q product detectors and the carrier recovery circuit. The carrier recovery circuit reproduces the original transmit carrier oscillator signal. The recovered carrier must be frequency and phase coherent with the transmit reference carrier. The QPSK signal is demodulated in the I and Q product detectors, which generate the original I and Q data bits. The outputs of the product detectors are fed to the bit combining circuit, where they are converted from parallel I and Q data channels to a single binary output data stream. The incoming QPSK signal may be any one of the four possible output phases shown in Figure 2-18. To illustrate the demodulation process, let the incoming QPSK signal be  $-\sin \omega_c t + \cos \omega_c t$ . Mathematically, the demodulation process is as follows.

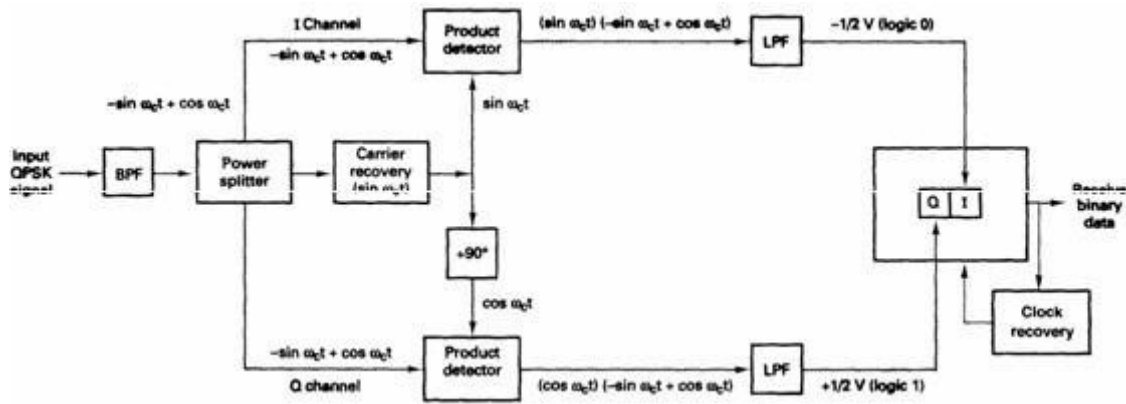

FIGURE 2-21 QPSK receiver

The receive QPSK signal  $(-\sin \omega_c t + \cos \omega_c t)$  is one of the inputs to the I product detector. The other input is the recovered carrier  $(\sin \omega_c t)$ . The output of the I product detector is

$$\begin{aligned}
 I &= \underbrace{(-\sin \omega_c t + \cos \omega_c t)}_{\text{QPSK input signal}} \underbrace{(\sin \omega_c t)}_{\text{carrier}} \\
 &= (-\sin \omega_c t)(\sin \omega_c t) + (\cos \omega_c t)(\sin \omega_c t) \\
 &= -\sin^2 \omega_c t + (\cos \omega_c t)(\sin \omega_c t) \\
 &= -\frac{1}{2}(1 - \cos 2\omega_c t) + \frac{1}{2} \sin(\omega_c + \omega_c)t + \frac{1}{2} \sin(\omega_c - \omega_c)t \\
 I &= -\frac{1}{2} + \frac{1}{2} \cos 2\omega_c t + \frac{1}{2} \sin 2\omega_c t + \frac{1}{2} \sin 0 \\
 &= -\frac{1}{2} \text{V (logic 0)}
 \end{aligned} \tag{2.23}$$

Again, the receive QPSK signal  $(-\sin \omega_c t + \cos \omega_c t)$  is one of the inputs to the Q product detector. The other input is the recovered carrier shifted  $90^\circ$  in phase  $(\cos \omega_c t)$ . The output of the Q product detector is

$$\begin{aligned}
Q &= \underbrace{(-\sin \omega_c t + \cos \omega_c t)}_{\text{QPSK input signal}} \underbrace{(\cos \omega_c t)}_{\text{carrier}} \\
&= \cos^2 \omega_c t - (\sin \omega_c t)(\cos \omega_c t) \\
&= \frac{1}{2}(1 + \cos 2\omega_c t) - \frac{1}{2}\sin(\omega_c + \omega_c)t - \frac{1}{2}\sin(\omega_c - \omega_c)t \\
Q &= \frac{1}{2} + \frac{1}{2}\cos 2\omega_c t - \frac{1}{2}\sin 2\omega_c t - \frac{1}{2}\sin 0 \\
&= \frac{1}{2}V(\text{logic 1})
\end{aligned} \tag{2.24}$$

The demodulated I and Q bits (0 and 1, respectively) correspond to the constellation diagram and truth table for the QPSK modulator shown in Figure 2-18.

#### DIFFERENTIAL PHASE SHIFT KEYING (DPSK):

In DPSK (Differential Phase Shift Keying) the phase of the modulated signal is shifted relative to the previous signal element. No reference signal is considered here. The signal phase follows the high or low state of the previous element. This DPSK technique doesn't need a reference oscillator.

The following figure represents the model waveform of DPSK.

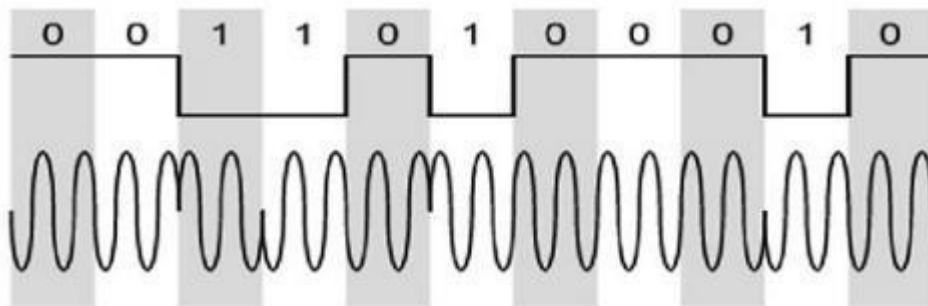

It is seen from the above figure that, if the data bit is LOW i.e., 0, then the phase of the signal is not reversed, but is continued as it was. If the data is HIGH i.e., 1, then the phase of the signal is reversed, as with NRZI, invert on 1 (a form of differential encoding).

If we observe the above waveform, we can say that the HIGH state represents an **M** in the modulating signal and the LOW state represents a **W** in the modulating signal.

The word binary represents two-bits. **M** simply represents a digit that corresponds to the number of conditions, levels, or combinations possible for a given number of binary variables.

This is the type of digital modulation technique used for data transmission in which instead of one-bit, two or **more bits are transmitted at a time**. As a single signal is used for multiple bit transmission, the channel bandwidth is reduced.

### **DBPSK TRANSMITTER.:**

Figure 2-37a shows a simplified block diagram of a *differential binary phase-shift keying* (DBPSK) transmitter. An incoming information bit is XNORed with the preceding bit prior to entering the BPSK modulator (balanced modulator).

For the first data bit, there is no preceding bit with which to compare it. Therefore, an initial reference bit is assumed. Figure 2-37b shows the relationship between the input data, the XNOR output data, and the phase at the output of the balanced modulator. If the initial reference bit is assumed a logic 1, the output from the XNOR circuit is simply the complement of that shown.

In Figure 2-37b, the first data bit is XNORed with the reference bit. If they are the same, the XNOR output is a logic 1; if they are different, the XNOR output is a logic 0. The balanced modulator operates the same as a conventional BPSK modulator; a logic 1 produces  $+\sin \omega_c t$  at the output, and A logic 0 produces  $-\sin \omega_c t$  at the output.



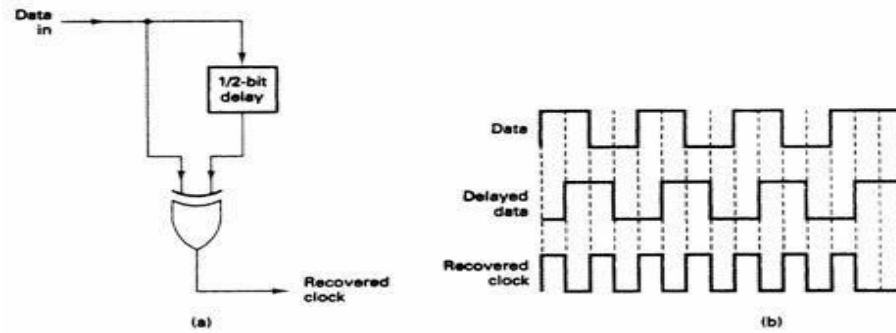

FIGURE 9-40 (a) Clock recovery circuit; (b) timing diagram

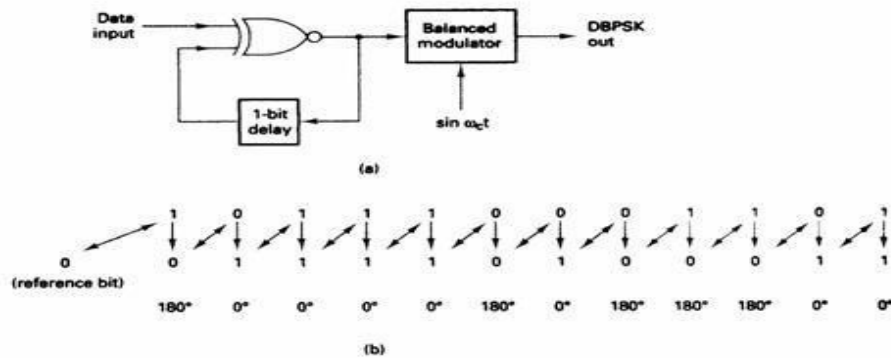
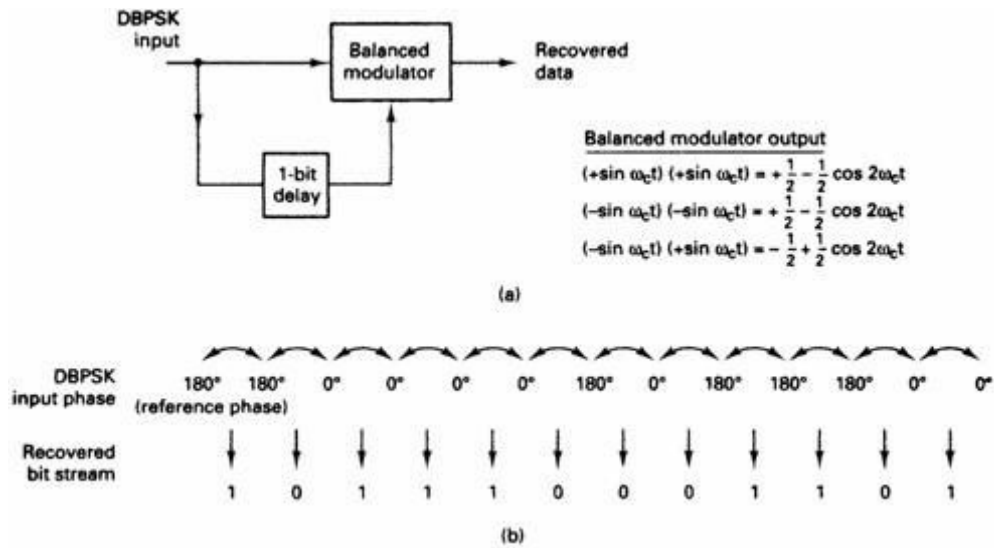

FIGURE 2-37 DBPSK modulator (a) block diagram (b) timing diagram

### BPSK RECEIVER:

Figure 9-38 shows the block diagram and timing sequence for a DBPSK receiver. The received signal is delayed by one bit time, then compared with the next signaling element in the balanced modulator. If they are the same, a logic 1 (+ voltage) is generated. If they are different, a logic 0 (- voltage) is generated. [f the reference phase is incorrectly assumed, only the first demodulated bit is in error. Differential encoding can be implemented with higher-than-binary digital modulation schemes, although the differential algorithms are much more complicated than for DBPSK.

The primary advantage of DBPSK is the simplicity with which it can be implemented. With DBPSK, no carrier recovery circuit is needed. A disadvantage of DBPSK is, that it requires between 1 dB and 3 dB more signal-to-noise ratio to achieve the same bit error rate as that of absolute PSK.



**FIGURE 2-38 DBPSK demodulator: (a) block diagram; (b) timing sequence**

### COHERENT RECEPTION OF FSK:

The coherent demodulator for the coherent FSK signal falls in the general form of coherent demodulators described in Appendix B. The demodulator can be implemented with two correlators as shown in Figure 3.5, where the two reference signals are  $\cos(2\pi f_1 t)$  and  $\cos(2\pi f_2 t)$ . They must be synchronized with the received signal. The receiver is optimum in the sense that it minimizes the error probability for equally likely binary signals. Even though the receiver is rigorously derived in Appendix B, some heuristic explanation here may help understand its operation. When  $s_1(t)$  is transmitted, the upper correlator yields a signal 1 with a positive signal component and a noise component. However, the lower correlator output, due to the signals' orthogonality, has only a noise component. Thus the output of the summer is most likely above zero, and the threshold detector will most likely produce a 1. When  $s_2(t)$  is transmitted, opposite things happen to the two correlators and the threshold detector will most likely produce a 0. However, due to the noise nature that its values range from  $-\infty$  to  $\infty$ , occasionally the noise amplitude might overpower the signal amplitude, and then detection errors will happen. An alternative to Figure 3.5 is to use just one correlator with the reference signal  $\cos(2\pi f_1 t) - \cos(2\pi f_2 t)$  (Figure 3.6). The correlator in Figure 3.6 can be replaced by a matched filter that matches  $\cos(2\pi f_1 t) - \cos(2\pi f_2 t)$  (Figure 3.7). All

implementations are equivalent in terms of error performance (see Appendix B). Assuming an AWGN channel, the received signal is

$$r(t) = s_i(t) + n(t), \quad i = 1, 2$$

where  $n(t)$  is the additive white Gaussian noise with zero mean and a two-sided power spectral density  $N_0/2$ . From (B.33) the bit error probability for any equally likely binary signals is

$$P_b = Q \left( \sqrt{\frac{E_1 + E_2 - 2\rho_{12}\sqrt{E_1 E_2}}{2N_0}} \right)$$

where  $N_0/2$  is the two-sided power spectral density of the additive white Gaussian noise. For Sunde's FSK signals  $E_1 = E_2 = E_b$ ,  $\rho_{12} = 0$  (orthogonal). thus the error probability is

$$P_b = Q \left( \sqrt{\frac{E_b}{N_0}} \right)$$

where  $E_b = A^2T/2$  is the average bit energy of the FSK signal. The above  $P_b$  is plotted in Figure 3.8 where  $P_b$  of noncoherently demodulated FSK, whose expression will be given shortly, is also plotted for comparison.

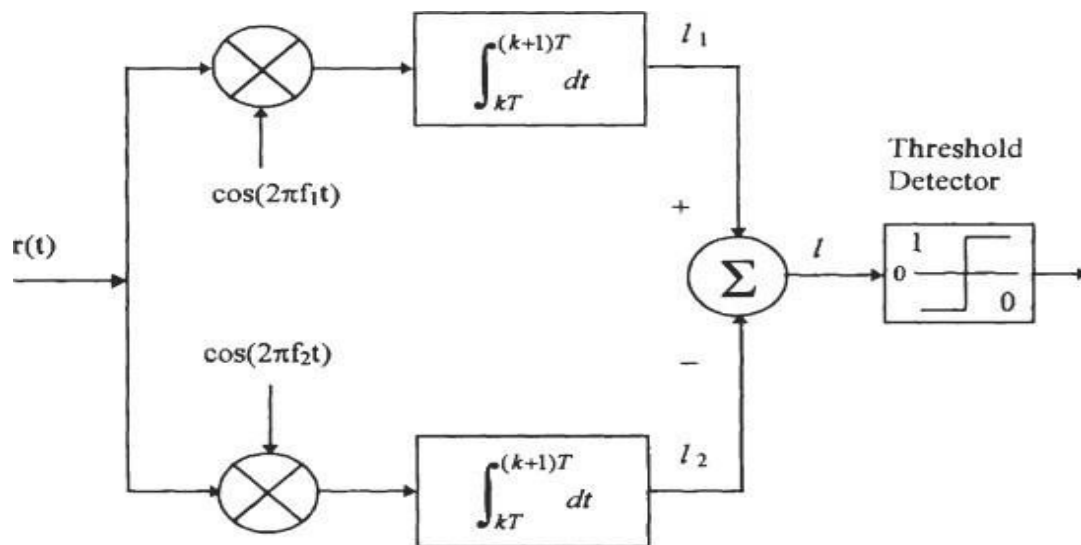

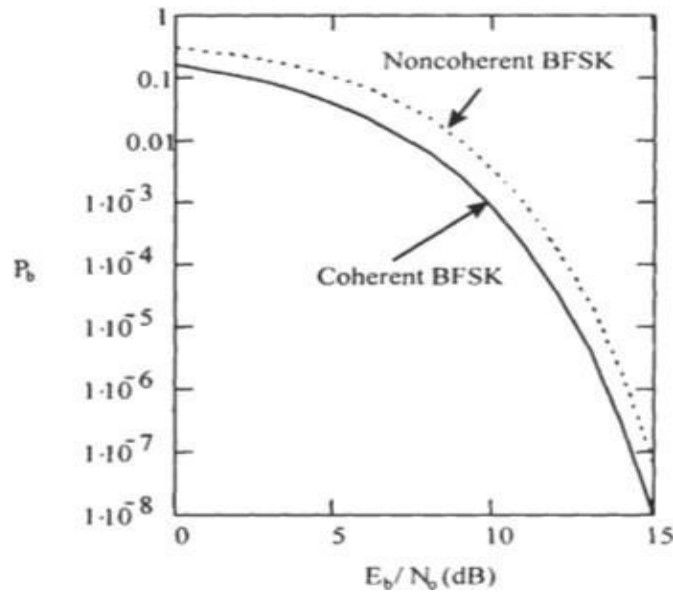

Figure:  $P_b$  of coherently and non-coherently demodulated FSK signal.

#### NONCOHERENT DEMODULATION AND ERROR PERFORMANCE:

Coherently FSK signals can be noncoherently demodulated to avoid the carrier recovery. Noncoherently generated FSK can only be noncoherently demodulated. We refer to both cases as noncoherent FSK. In both cases the demodulation problem becomes a problem of detecting signals with unknown phases. In Appendix B we have shown that the optimum receiver is a quadrature receiver. It can be implemented using correlators or equivalently, matched filters. Here we assume that the binary noncoherent FSK signals are equally likely and with equal energies. Under these assumptions, the demodulator using correlators is shown in Figure 3.9. Again, like in the coherent case, the optimality of the receiver has been rigorously proved (Appendix B). However, we can easily understand its operation by some heuristic argument as follows. The received signal (ignoring noise for the moment) with an unknown phase can be written as

$$\begin{aligned}
 s_i(t, \theta) &= A \cos(2\pi f_i t + \theta), \quad i = 1, 2 \\
 &= A \cos \theta \cos 2\pi f_i t - A \sin \theta \sin 2\pi f_i t
 \end{aligned}$$

The signal consists of an in phase component  $A \cos \theta \cos 2\pi f_c t$  and a quadrature component  $A \sin \theta \sin 2\pi f_c t$ . Thus the signal is partially correlated with  $\cos 2\pi f_c t$  and partially correlated with  $\sin 2\pi f_c t$ . Therefore we use two correlators to collect the signal energy in these two parts. The outputs of the in phase and quadrature correlators will be  $\cos \theta$  and  $\sin \theta$ , respectively. Depending on the value of the unknown phase  $\theta$ , these two outputs could be anything in  $(-1, 1)$ . Fortunately the squared sum of these two signals is not dependent on the unknown phase. That is

$$\left(\frac{AT}{2} \cos \theta\right)^2 + \left(\frac{AT}{2} \sin \theta\right)^2 = \frac{A^2 T^2}{2}$$

This quantity is actually the mean value of the statistics  $I$  when signal  $s_i(t)$  is transmitted and noise is taken into consideration. When  $s_i(t)$  is not transmitted the mean value of  $I$  is 0. The comparator decides which signal is sent by checking these  $I$ 's. The matched filter equivalence to Figure 3.9 is shown in Figure 3.10 which has the same error performance. For implementation simplicity we can replace the matched filters by bandpass filters centered at  $f_1$  and  $f_2$ , respectively (Figure 3.11).

However, if the bandpass filters are not matched to the FSK signals, degradation to

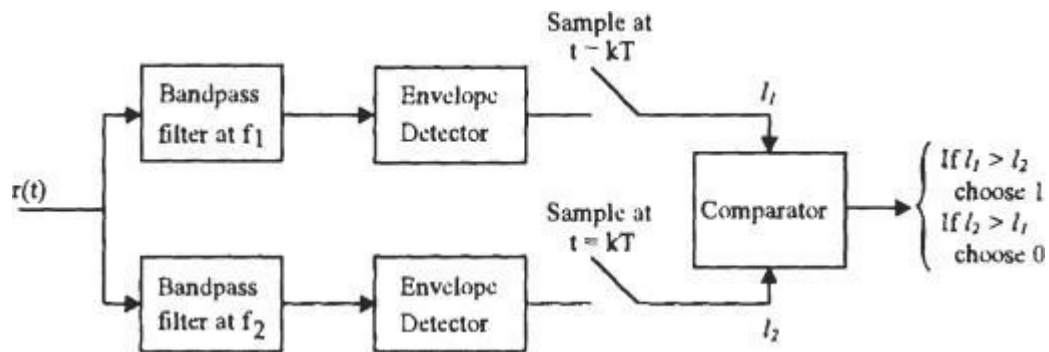

various extents will result. The bit error probability can be derived using the correlator demodulator (Appendix B). Here we further assume that the FSK signals are orthogonal, then from Appendix B the error probability is

$$P_b = \frac{1}{2} e^{-E_b/2N_0}$$

## PART-2

### DATATRANSMISSION

#### BASE BAND SIGNAL RECEIVER:

Consider that a binary encoded signal consists of a time sequence of voltage levels  $+V$  or  $-V$ . if there is a guard interval between the bits, the signal forms a sequence of positive and negative pulses. in either case there is no particular interest in preserving the waveform of the signal after reception .we are interested only in knowing within each bit interval whether the transmitted voltage was  $+V$  or  $-V$ . With noise present, the receives signal and noise together will yield sample values generally different from  $\pm V$ . In this case, what deduction shall we make from the sample value concerning the transmitted bit?

Suppose that the noise is gaussian and therefore the noise voltage has a probability density which is entirely symmetrical with respect to zero volts. Then the probability that the noise has increased the sample value is the same as the probability that the noise has decreased the sample value. It then seems entirely reasonable that we can do no better than to assume that if the sample value is positive the transmitted level was  $+V$ , and if the sample value is negative the transmitted level was  $-V$ . It is, of course, possible that at the sampling time the noise voltage may be of magnitude larger than  $V$  and of a polarity opposite to the polarity assigned to the transmitted bit. In this case an error will be made as indicated in Fig. 11.1-1. Here the transmitted bit is represented by the voltage  $+V$  which is sustained over an interval  $T$  from  $t_1$  to  $t_2$ . Noise has been superimposed on the level  $+V$  so that the voltage  $v$  represents the received signal and noise. If now the sampling should happen to take place at a time  $t = t_1 + \Delta t$ , an error will have been made.

We can reduce the probability of error by processing the received signal plus noise in such a manner that we are then able to find a sample time where the sample voltage due to the signal is emphasized relative to the sample voltage due to the noise. Such a processor (receiver) is shown in Fig. 11.1-2. The signal input during a bit interval is indicated. As a matter of convenience we have set  $t = 0$  at the beginning of the interval. The waveform of the signal  $s(t)$  before  $t = 0$  and after  $t = T$  has not been indicated since, as will appear, the operation of the receiver during each bit interval is independent of the waveform during past and future bit intervals.

The signal  $s(t)$  with added white gaussian noise  $n(t)$  of power spectral density  $\eta/2$  is presented to an integrator. At time  $t = 0 +$  we require that capacitor  $C$  be uncharged. Such a discharged condition may be ensured by a brief closing of switch  $SW_1$  at time  $t = 0 -$ , thus relieving  $C$  of any charge it may have acquired during the previous interval. The sample is taken at the output of the integrator by closing this sampling switch  $SW_2$ . This sample is taken at the end of the bit interval, at  $t = T$ . The signal processing indicated in Fig. 11.1-2 is described by the phrase *integrate and dump*, the term *dump* referring to the abrupt discharge of the capacitor after each sampling.

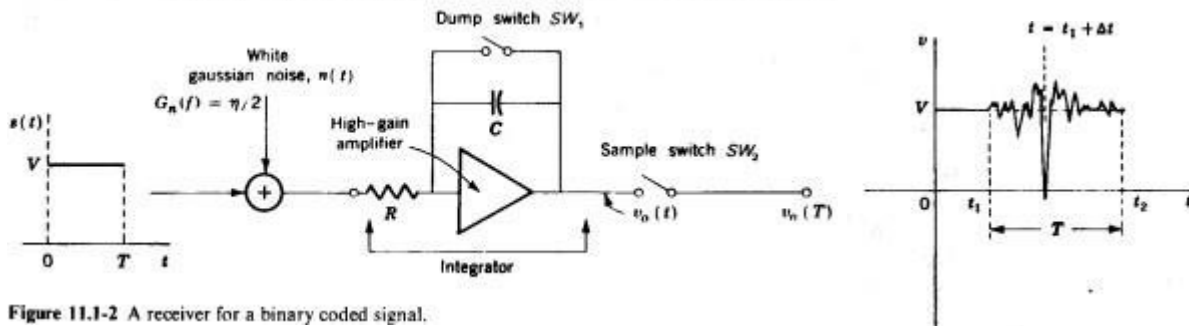

Figure 11.1-2 A receiver for a binary coded signal.

### Peak Signal to RMS Noise Output Voltage Ratio

The integrator yields an output which is the integral of its input multiplied by  $1/RC$ . Using  $\tau = RC$ , we have

$$v_o(T) = \frac{1}{\tau} \int_0^T [s(t) + n(t)] dt = \frac{1}{\tau} \int_0^T s(t) dt + \frac{1}{\tau} \int_0^T n(t) dt \quad (11.1-1)$$

The sample voltage due to the signal is

$$s_o(T) = \frac{1}{\tau} \int_0^T V dt = \frac{VT}{\tau} \quad (11.1-2)$$

The sample voltage due to the noise is

$$n_o(T) = \frac{1}{\tau} \int_0^T n(t) dt \quad (11.1-3)$$

This noise-sampling voltage  $n_o(T)$  is a gaussian random variable in contrast with  $n(t)$ , which is a gaussian random process.

The variance of  $n_o(T)$  was found in Sec. 7.9 [see Eq. (7.9-17)] to be

$$\sigma_o^2 = \overline{n_o^2(T)} = \frac{\eta T}{2\tau^2} \quad (11.1-4)$$

and, as noted in Sec. 7.3,  $n_o(T)$  has a gaussian probability density.

The output of the integrator, before the sampling switch, is  $v_o(t) = s_o(t) + n_o(t)$ . As shown in Fig. 11.1-3a, the signal output  $s_o(t)$  is a ramp, in each bit interval, of duration  $T$ . At the end of the interval the ramp attains the voltage  $s_o(T)$  which is  $+VT/\tau$  or  $-VT/\tau$ , depending on whether the bit is a 1 or a 0. At the end of each interval the switch  $SW_1$  in Fig. 11.1-2 closes momentarily to discharge the capacitor so that  $s_o(t)$  drops to zero. The noise  $n_o(t)$ , shown in Fig. 11.1-3b, also starts each interval with  $n_o(0) = 0$  and has the random value  $n_o(T)$  at the end of each interval. The sampling switch  $SW_2$  closes briefly just before the closing of  $SW_1$  and hence reads the voltage

$$v_o(T) = s_o(T) + n_o(T) \quad (11.1-5)$$

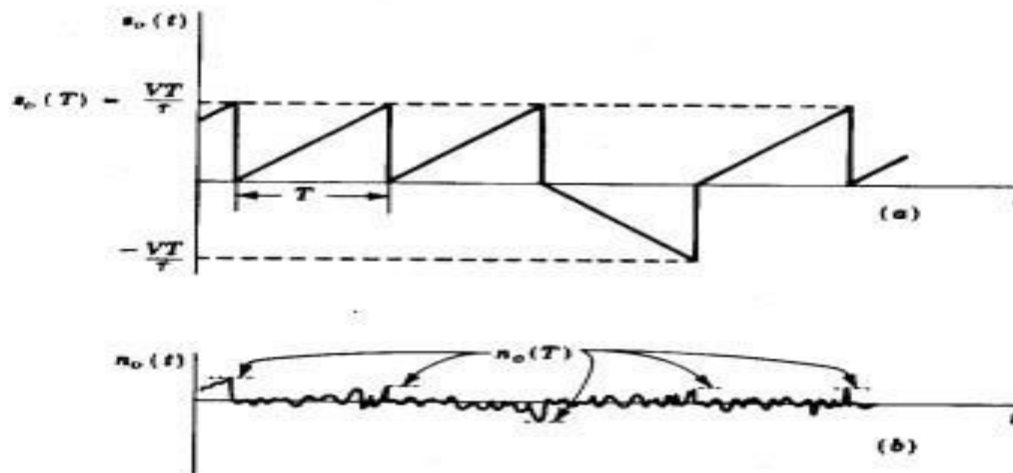

Figure 11.1-3 (a) The signal output and (b) the noise output of the integrator of Fig. 11.1-2.

We would naturally like the output signal voltage to be as large as possible in comparison with the noise voltage. Hence a figure of merit of interest is the signal-to-noise ratio

$$\frac{[s_o(T)]^2}{[n_o(T)]^2} = \frac{2}{\eta} V^2 T \quad (11.1-6)$$

This result is calculated from Eqs. (11.1-2) and (11.1-4). Note that the signal-to-noise ratio increases with increasing bit duration  $T$  and that it depends on  $V^2 T$  which is the normalized energy of the bit signal. Therefore, a bit represented by a narrow, high amplitude signal and one by a wide, low amplitude signal are equally effective, provided  $V^2 T$  is kept constant.

It is instructive to note that the integrator filters the signal and the noise such that the signal voltage increases linearly with time, while the standard deviation (rms value) of the noise increases more slowly, as  $\sqrt{T}$ . Thus, the integrator enhances the signal relative to the noise, and this enhancement increases with time as shown in Eq. (11.1-6).

## PROBABILITY OF ERROR

Since the function of a receiver of a data transmission is to distinguish the bit 1 from the bit 0 in the presence of noise, a most important characteristic is the probability that an error will be made in such a determination. We now calculate this error probability  $P_e$  for the integrate and dump receiver of Fig. 11.1-2



We have seen that the probability density of the noise sample  $n_o(T)$  is gaussian and hence appears as in Fig. 11.2-1. The density is therefore given by

$$f[n_o(T)] = \frac{e^{-n_o^2(T)/2\sigma_o^2}}{\sqrt{2\pi\sigma_o^2}} \quad (11.2-1)$$

where  $\sigma_o^2$ , the variance, is  $\sigma_o^2 \equiv \overline{n_o^2(T)}$  given by Eq. (11.1-4). Suppose, then, that during some bit interval the input-signal voltage is held at, say,  $-V$ . Then, at the sample time, the signal sample voltage is  $s_o(T) = -VT/\tau$ , while the noise sample is  $n_o(T)$ . If  $n_o(T)$  is positive and larger in magnitude than  $VT/\tau$ , the total sample voltage  $v_o(T) = s_o(T) + n_o(T)$  will be positive. Such a positive sample voltage will result in an error, since as noted earlier, we have instructed the receiver to interpret such a positive sample voltage to mean that the signal voltage was  $+V$  during the bit interval. The probability of such a misinterpretation, that is, the probability that  $n_o(T) > VT/\tau$ , is given by the area of the shaded region in Fig. 11.2-1. The probability of error is, using Eq. (11.2-1).

$$P_e = \int_{VT/\tau}^{\infty} f[n_o(T)] dn_o(T) = \int_{VT/\tau}^{\infty} \frac{e^{-n_o^2(T)/2\sigma_o^2}}{\sqrt{2\pi\sigma_o^2}} dn_o(T) \quad (11.2-2)$$

Defining  $x \equiv n_o(T)/\sqrt{2}\sigma_o$ , and using Eq. (11.1-4), Eq. (11.2-2) may be rewritten as

$$\begin{aligned} P_e &= \frac{1}{2} \frac{2}{\sqrt{\pi}} \int_{x=V\sqrt{T}/\eta}^{\infty} e^{-x^2} dx \\ &= \frac{1}{2} \operatorname{erfc} \left( V \sqrt{\frac{T}{\eta}} \right) = \frac{1}{2} \operatorname{erfc} \left( \frac{V^2 T}{\eta} \right)^{1/2} = \frac{1}{2} \operatorname{erfc} \left( \frac{E_s}{\eta} \right)^{1/2} \end{aligned} \quad (11.2-3)$$

in which  $E_s = V^2 T$  is the signal energy of a bit.

If the signal voltage were held instead at  $+V$  during some bit interval, then it is clear from the symmetry of the situation that the probability of error would again be given by  $P_e$  in Eq. (11.2-3). Hence Eq. (11.2-3) gives  $P_e$  quite generally.

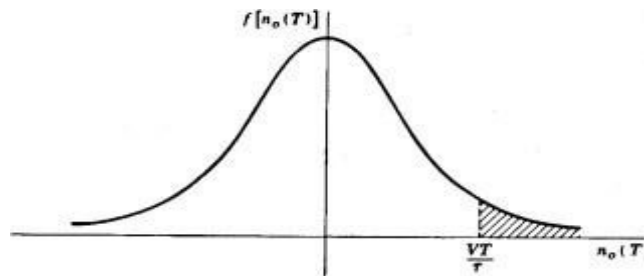

Figure 11.2-1 The gaussian probability density of the noise sample  $n_o(T)$ .

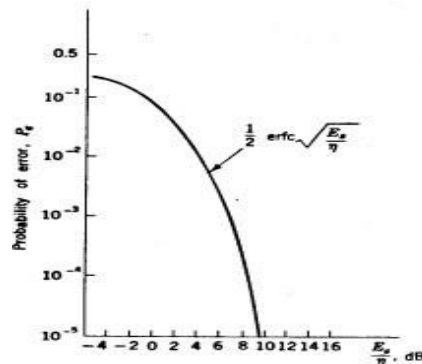

Figure 11.2-2 Variation of  $P_e$  versus  $E_s/\eta$ .

The probability of error  $p_e$ , as given in eq.(11.2-3), is plotted in fig.11.2-2. note that  $p_e$  decreases rapidly as  $E_s/\eta$  increases. The maximum value of  $p_e$  is  $1/2$ . thus ,even if the signal is entirely lost in the noise so that any determination of the receiver is a sheer guess, the receiver cannot be wrong more than half the time on the average.

### THE OPTIMUM FILTER:

In the receiver system of Fig 11.1-2, the signal was passed through a filter(integrator),so that at the sampling time the signal voltage might be emphasized in comparison with the noise voltage. We are naturally led to risk whether the integrator is the optimum filter for the purpose of minimizing the probability of error. We shall find that the received signal contemplated in system of fig 11.1-2 the integrator is indeed the optimum filter. However, before returning specifically to the integrator receiver.

We assume that the received signal is a binary waveform. One binary digit is represented by a signal waveform  $S_1(t)$  which persists for time  $T$ , while the other bit is represented by the waveform  $S_2(t)$  which also lasts for an interval  $T$ . For example, in the transmission at baseband, as shown in fig 11.1-2  $S_1(t)=+V$ ; for other modulation systems, different waveforms are transmitted. for example for PSK signaling ,  $S_1(t)=A\cos\omega_0 t$  and  $S_2(t)=-A\cos\omega_0 t$ ; while for FSK,  $S_1(t)=A\cos(\omega_0+\Omega)t$ .

As shown in Fig. 11.3-1 the input, which is  $s_1(t)$  or  $s_2(t)$ , is corrupted by the addition of noise  $n(t)$ . The noise is gaussian and has a spectral density  $G(f)$ . [In most cases of interest the noise is white, so that  $G(f) = \eta/2$ . However, we shall assume the more general possibility, since it introduces no complication to do so.] The signal and noise are filtered and then sampled at the end of each bit interval. The output sample is either  $v_o(T) = s_{o1}(T) + n_o(T)$  or  $v_o(T) = s_{o2}(T) + n_o(T)$ . We assume that immediately after each sample, every energy-storing element in the filter has been discharged.

We have already considered in Sec. 2.22, the matter of signal determination in the presence of noise. Thus, we note that in the absence of noise the output sample would be  $v_o(T) = s_{o1}(T)$  or  $s_{o2}(T)$ . When noise is present we have shown that to minimize the probability of error one should assume that  $s_1(t)$  has been transmitted if  $v_o(T)$  is closer to  $s_{o1}(T)$  than to  $s_{o2}(T)$ . Similarly, we assume  $s_2(t)$  has been transmitted if  $v_o(T)$  is closer to  $s_{o2}(T)$ . The decision boundary is therefore midway between  $s_{o1}(T)$  and  $s_{o2}(T)$ . For example, in the baseband system of Fig. 11.1-2, where  $s_{o1}(T) = VT/\tau$  and  $s_{o2}(T) = -VT/\tau$ , the decision boundary is  $v_o(T) = 0$ . In general, we shall take the decision boundary to be

$$v_o(T) = \frac{s_{o1}(T) + s_{o2}(T)}{2} \quad (11.3-1)$$

The probability of error for this general case may be deduced as an extension of the considerations used in the baseband case. Suppose that  $s_{o1}(T) > s_{o2}(T)$  and that  $s_2(t)$  was transmitted. If, at the sampling time, the noise  $n_o(T)$  is positive and larger in magnitude than the voltage difference  $\frac{1}{2}[s_{o1}(T) + s_{o2}(T)] - s_{o2}(T)$ , an error will have been made. That is, an error [we decide that  $s_1(t)$  is transmitted rather than  $s_2(t)$ ] will result if

$$n_o(T) \geq \frac{s_{o1}(T) - s_{o2}(T)}{2} \quad (11.3-2)$$

Hence probability of error is

$$P_e = \int_{\sqrt{(s_{o1}(T) - s_{o2}(T))/2}}^{\infty} \frac{e^{-n_o^2(T)/2\sigma_o^2}}{\sqrt{2\pi\sigma_o^2}} dn_o(T) \quad (11.3-3)$$

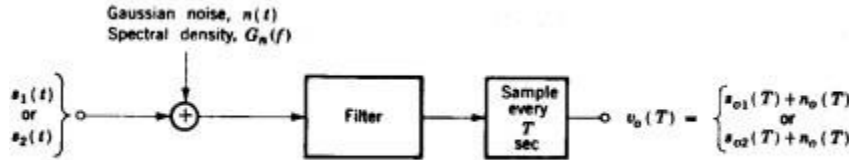

Figure 11.3-1 A receiver for binary coded signalling.

If we make the substitution  $x \equiv n_o(T)/\sqrt{2}\sigma_o$ , Eq. (11.3-3) becomes

$$P_e = \frac{1}{2} \frac{2}{\sqrt{\pi}} \int_{|s_{o1}(T) - s_{o2}(T)|/2\sqrt{2}\sigma_o}^{\infty} e^{-x^2} dx \quad (11.3-4a)$$

$$P_e = \frac{1}{2} \operatorname{erfc} \left[ \frac{s_{o1}(T) - s_{o2}(T)}{2\sqrt{2}\sigma_o} \right] \quad (11.3-4b)$$

Note that for the case  $s_{o1}(T) = VT/\tau$  and  $s_{o2}(T) = -VT/\tau$ , and, using Eq. (11.1-4), Eq. (11.3-4b) reduces to Eq. (11.2-3) as expected.

The complementary error function is a monotonically decreasing function of its argument. (See Fig. 11.2-2.) Hence, as is to be anticipated,  $P_e$  decreases as the difference  $s_{o1}(T) - s_{o2}(T)$  becomes larger and as the rms noise voltage  $\sigma_o$  becomes smaller. The optimum filter, then, is the filter which maximizes the ratio

$$\gamma = \frac{s_{o1}(T) - s_{o2}(T)}{\sigma_o} \quad (11.3-5)$$

We now calculate the transfer function  $H(f)$  of this optimum filter. As a matter of mathematical convenience we shall actually maximize  $\gamma^2$  rather than  $\gamma$ .

### Calculation of the Optimum-Filter Transfer Function $H(f)$

The fundamental requirement we make of a binary encoded data receiver is that it distinguishes the voltages  $s_1(t) + n(t)$  and  $s_2(t) + n(t)$ . We have seen that the ability of the receiver to do so depends on how large a particular receiver can make  $\gamma$ . It is important to note that  $\gamma$  is proportional not to  $s_1(t)$  nor to  $s_2(t)$ , but rather to the *difference* between them. For example, in the baseband system we represented the signals by voltage levels  $+V$  and  $-V$ . But clearly, if our only interest was in distinguishing levels, we would do just as well to use  $+2$  volts and  $0$  volt, or  $+8$  volts and  $+6$  volts, etc. (The  $+V$  and  $-V$  levels, however, have the advantage of requiring the least average power to be transmitted.) Hence, while  $s_1(t)$  or  $s_2(t)$  is the received signal, the signal which is to be compared with the noise, i.e., the signal which is relevant in all our error-probability calculations, is the difference signal

$$p(t) \equiv s_1(t) - s_2(t) \quad (11.3-6)$$

Thus, for the purpose of calculating the minimum error probability, we shall assume that the input signal to the optimum filter is  $p(t)$ . The corresponding *output signal* of the filter is then

$$p_o(t) \equiv s_{o1}(t) - s_{o2}(t) \quad (11.3-7)$$

We shall let  $P(f)$  and  $P_o(f)$  be the Fourier transforms, respectively, of  $p(t)$  and  $p_o(t)$ .

If  $H(f)$  is the transfer function of the filter,

$$P_o(f) = H(f)P(f) \quad (11.3-8)$$

and 
$$p_o(T) = \int_{-\infty}^{\infty} P_o(f)e^{j2\pi fT} df = \int_{-\infty}^{\infty} H(f)P(f)e^{j2\pi fT} df \quad (11.3-9)$$

The input noise to the optimum filter is  $n(t)$ . The output noise is  $n_o(t)$  which has a power spectral density  $G_{n_o}(f)$  and is related to the power spectral density of the input noise  $G_n(f)$  by

$$G_{n_o}(f) = |H(f)|^2 G_n(f) \quad (11.3-10)$$

Using Parseval's theorem (Eq. 1.13-5), we find that the normalized output noise power, i.e., the noise variance  $\sigma_o^2$ , is

$$\sigma_o^2 = \int_{-\infty}^{\infty} G_{n_o}(f) df = \int_{-\infty}^{\infty} |H(f)|^2 G_n(f) df \quad (11.3-11)$$

From Eqs. (11.3-9) and (11.3-11) we now find that

$$\gamma^2 = \frac{p_o^2(T)}{\sigma_o^2} = \frac{|\int_{-\infty}^{\infty} H(f)P(f)e^{j2\pi fT} df|^2}{\int_{-\infty}^{\infty} |H(f)|^2 G_n(f) df} \quad (11.3-12)$$

Equation (11.3-12) is unaltered by the inclusion or deletion of the absolute value sign in the numerator since the quantity within the magnitude sign  $p_o(T)$  is a positive real number. The sign has been included, however, in order to allow further development of the equation through the use of the *Schwarz inequality*.

The *Schwarz inequality* states that given arbitrary complex functions  $X(f)$  and  $Y(f)$  of a common variable  $f$ , then

$$\left| \int_{-\infty}^{\infty} X(f)Y(f) df \right|^2 \leq \int_{-\infty}^{\infty} |X(f)|^2 df \int_{-\infty}^{\infty} |Y(f)|^2 df \quad (11.3-13)$$

The equal sign applies when

$$X(f) = KY^*(f) \quad (11.3-14)$$

where  $K$  is an arbitrary constant and  $Y^*(f)$  is the complex conjugate of  $Y(f)$ .

We now apply the Schwarz inequality to Eq. (11.3-12) by making the identification

$$X(f) \equiv \sqrt{G_n(f)} H(f) \quad (11.3-15)$$

and 
$$Y(f) \equiv \frac{1}{\sqrt{G_n(f)}} P(f)e^{j2\pi fT} \quad (11.3-16)$$

Using Eqs. (11.3-15) and (11.3-16) and using the Schwarz inequality, Eq. (11.3-13), we may rewrite Eq. (11.3-12) as

$$\frac{p_o^2(T)}{\sigma_o^2} = \frac{|\int_{-\infty}^{\infty} X(f)Y(f) df|^2}{\int_{-\infty}^{\infty} |X(f)|^2 df} \leq \int_{-\infty}^{\infty} |Y(f)|^2 df \quad (11.3-17)$$

or, using Eq. (11.3-16),

$$\frac{p_o^2(T)}{\sigma_n^2} \leq \int_{-\infty}^{\infty} |Y(f)|^2 df = \int_{-\infty}^{\infty} \frac{|P(f)|^2}{G_n(f)} df \quad (11.3-18)$$

The ratio  $p_o^2(T)/\sigma_n^2$  will attain its maximum value when the equal sign in Eq. (11.3-18) may be employed as is the case when  $X(f) = KY^*(f)$ . We then find from Eqs. (11.3-15) and (11.3-16) that the optimum filter which yields such a maximum ratio  $p_o^2(T)/\sigma_n^2$  has a transfer function

$$H(f) = K \frac{P^*(f)}{G_n(f)} e^{-j2\pi fT} \quad (11.3-19)$$

Correspondingly, the maximum ratio is, from Eq. (11.3-18),

$$\left[ \frac{p_o^2(T)}{\sigma_n^2} \right]_{\max} = \int_{-\infty}^{\infty} \frac{|P(f)|^2}{G_n(f)} df \quad (11.3-20)$$

In succeeding sections we shall have occasion to apply Eqs. (11.3-19) and (11.3-20) to a number of cases of interest.

## 11.4 WHITE NOISE: THE MATCHED FILTER

An optimum filter which yields a maximum ratio  $p_o^2(T)/\sigma_n^2$  is called a *matched filter* when the input noise is *white*. In this case  $G_n(f) = \eta/2$ , and Eq. (11.3-19) becomes

$$H(f) = K \frac{P^*(f)}{\eta/2} e^{-j2\pi fT} \quad (11.4-1)$$

The impulsive response of this filter, i.e., the response of the filter to a unit strength impulse applied at  $t = 0$ , is

$$h(t) = \mathcal{F}^{-1}[H(f)] = \frac{2K}{\eta} \int_{-\infty}^{\infty} P^*(f) e^{-j2\pi fT} e^{j2\pi ft} df \quad (11.4-2a)$$

$$= \frac{2K}{\eta} \int_{-\infty}^{\infty} P^*(f) e^{j2\pi f(t-T)} df \quad (11.4-2b)$$

A physically realizable filter will have an impulse response which is real, i.e., not complex. Therefore  $h(t) = h^*(t)$ . Replacing the right-hand member of Eq. (11.4-2b) by its complex conjugate, an operation which leaves the equation unaltered, we have

$$h(t) = \frac{2K}{\eta} \int_{-\infty}^{\infty} P(f) e^{j2\pi f(T-t)} df \quad (11.4-3a)$$

$$= \frac{2K}{\eta} p(T-t) \quad (11.4-3b)$$

Finally, since  $p(t) \equiv s_1(t) - s_2(t)$  [see Eq. (11.3-6)], we have

$$h(t) = \frac{2K}{\eta} [s_1(T-t) - s_2(T-t)] \quad (11.4-4)$$

The significance of these results for the matched filter may be more readily appreciated by applying them to a specific example. Consider then, as in Fig. 11.4-1a, that  $s_1(t)$  is a triangular waveform of duration  $T$ , while  $s_2(t)$ , as shown in Fig. 11.4-1b, is of identical form except of reversed polarity. Then  $p(t)$  is as shown in Fig. 11.4-1c, and  $p(-t)$  appears in Fig. 11.4-1d. The waveform  $p(-t)$  is the waveform  $p(t)$  rotated around the axis  $t = 0$ . Finally, the waveform  $p(T - t)$  called for as the impulse response of the filter in Eq. (11.4-3b) is this rotated waveform  $p(-t)$  translated in the positive  $t$  direction by amount  $T$ . This last translation ensures that  $h(t) = 0$  for  $t < 0$  as is required for a *causal* filter.

In general, the impulsive response of the matched filter consists of  $p(t)$  rotated about  $t=0$  and then delayed long enough (i.e., a time  $T$ ) to make the filter realizable. We may note in passing, that any additional delay that a filter might introduce would in no way interfere with the performance of the filter, for both signal and noise would be delayed by the same amount, and at the sampling time (which would need similarity to be delayed) the ratio of signal to noise would remain unaltered.

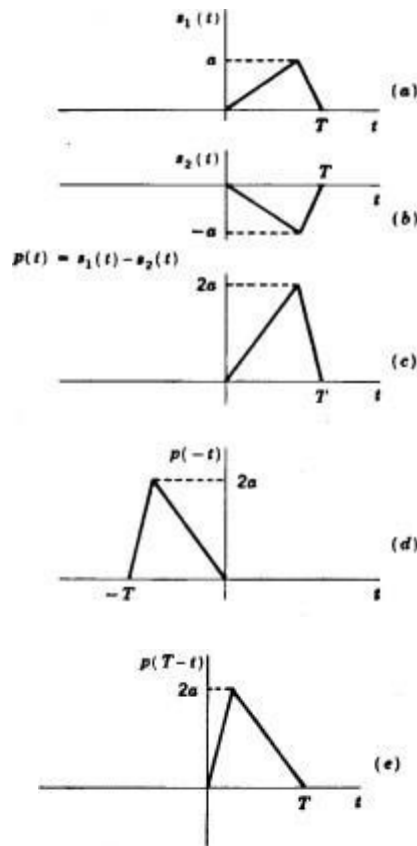

Figure 11.4-1 The signals (a)  $s_1(t)$ , (b)  $s_2(t)$ , and (c)  $p(t) = s_1(t) - s_2(t)$ . (d)  $p(t)$  rotated about the axis  $t = 0$ . (e) The waveform in (d) translated to the right by amount  $T$ .

## 11.5 PROBABILITY OF ERROR OF THE MATCHED FILTER

The probability of error which results when employing a matched filter, may be found by evaluating the maximum signal-to-noise ratio  $[p_o^2(T)/\sigma_o^2]_{\max}$  given by Eq. (11.3-20). With  $G_n(f) = \eta/2$ , Eq. (11.3-20) becomes

$$\left[ \frac{p_o^2(T)}{\sigma_o^2} \right]_{\max} = \frac{2}{\eta} \int_{-\infty}^{\infty} |P(f)|^2 df \quad (11.5-1)$$

From parseval's theorem we have

$$\int_{-\infty}^{\infty} |P(f)|^2 df = \int_{-\infty}^{\infty} p^2(t) dt = \int_0^T p^2(t) dt \quad (11.5-2)$$

In the last integral in Eq. (11.5-2), the limits take account of the fact that  $p(t)$  persists for only a time  $T$ . With  $p(t) = s_1(t) - s_2(t)$ , and using Eq. (11.5-2), we may write Eq. (11.5-1) as

$$\left[ \frac{p_o^2(T)}{\sigma_o^2} \right]_{\max} = \frac{2}{\eta} \int_0^T [s_1(t) - s_2(t)]^2 dt \quad (11.5-3a)$$

$$= \frac{2}{\eta} \left[ \int_0^T s_1^2(t) dt + \int_0^T s_2^2(t) dt - 2 \int_0^T s_1(t)s_2(t) dt \right] \quad (11.5-3b)$$

$$= \frac{2}{\eta} (E_{s1} + E_{s2} - 2E_{s12}) \quad (11.5-3c)$$

Here  $E_{s1}$  and  $E_{s2}$  are the energies, respectively, in  $s_1(t)$  and  $s_2(t)$ , while  $E_{s12}$  is the energy due to the correlation between  $s_1(t)$  and  $s_2(t)$ .

Suppose that we have selected  $s_1(t)$ , and let  $s_1(t)$  have an energy  $E_{s1}$ . Then it can be shown that if  $s_2(t)$  is to have the *same energy*, the optimum choice of  $s_2(t)$  is

$$s_2(t) = -s_1(t) \quad (11.5-4)$$

The choice is optimum in that it yields a maximum output signal  $p_o^2(T)$  for a given signal energy. Letting  $s_2(t) = -s_1(t)$ , we find

$$E_{s1} = E_{s2} = -E_{s12} \equiv E_s$$

and Eq. (11.5-3c) becomes

$$\left[ \frac{p_o^2(T)}{\sigma_o^2} \right]_{\max} = \frac{8E_s}{\eta} \quad (11.5-5)$$

Rewriting Eq. (11.3-4b) using  $p_o(T) = s_{o1}(T) - s_{o2}(T)$ , we have

$$P_e = \frac{1}{2} \operatorname{erfc} \left[ \frac{p_o(T)}{2\sqrt{2}\sigma_o} \right] = \frac{1}{2} \operatorname{erfc} \left[ \frac{p_o^2(T)}{8\sigma_o^2} \right]^{1/2} \quad (11.5-6)$$

Combining Eq. (11.5-6) with (11.5-5), we find that the minimum error probability  $(P_e)_{\min}$  corresponding to a maximum value of  $p_o^2(T)/\sigma_o^2$  is

$$(P_e)_{\min} = \frac{1}{2} \operatorname{erfc} \left\{ \frac{1}{8} \left[ \frac{p_o^2(T)}{\sigma_o^2} \right]_{\max} \right\}^{1/2} \quad (11.5-7)$$

$$= \frac{1}{2} \operatorname{erfc} \left( \frac{E_s}{\eta} \right)^{1/2} \quad (11.5-8)$$

We note that Eq. (11.5-8) establishes more generally the idea that the error probability depends only on the signal energy and not on the signal waveshape. Previously we had established this point only for signals which had constant voltage levels.

We note also that Eq. (11.5-8) gives  $(P_e)_{\min}$  for the case of the matched filter and when  $s_1(t) = -s_2(t)$ . In Sec. 11.2 we considered the case when  $s_1(t) = +V$  and  $s_2(t) = -V$  and the filter employed was an integrator. There we found [Eq. (11.2-3)] that the result for  $P_e$  was identical with  $(P_e)_{\min}$  given in Eq. (11.5-8). This agreement leads us to suspect that for an input signal where  $s_1(t) = +V$  and  $s_2(t) = -V$ , the integrator is the matched filter. Such is indeed the case. For when we have

$$s_1(t) = V \quad 0 \leq t \leq T \quad (11.5-9a)$$

$$s_2(t) = -V \quad 0 \leq t \leq T \quad (11.5-9b)$$

the impulse response of the matched filter is, from Eq. (11.4-4),

$$h(t) = \frac{2K}{\eta} [s_1(T-t) - s_2(T-t)] \quad (11.5-10)$$

The quantity  $s_1(T-t) - s_2(T-t)$  is a pulse of amplitude  $2V$  extending from  $t = 0$  to  $t = T$  and may be rewritten, with  $u(t)$  the unit step,

$$h(t) = \frac{2K}{\eta} (2V)[u(t) - u(t-T)] \quad (11.5-11)$$

The constant factor of proportionality  $4KV/\eta$  in the expression for  $h(t)$  (that is, the gain of the filter) has no effect on the probability of error since the gain affects signal and noise alike. We may therefore select the coefficient  $K$  in Eq. (11.5-11) so that  $4KV/\eta = 1$ . Then the inverse transform of  $h(t)$ , that is, the transfer function of the filter, becomes, with  $s$  the Laplace transform variable,

$$H(s) = \frac{1}{s} - \frac{e^{-sT}}{s} \quad (11.5-12)$$

The first term in Eq. (11.5-12) represents an integration beginning at  $t = 0$ , while the second term represents an integration with reversed polarity beginning at  $t = T$ . The overall response of the matched filter is an integration from  $t = 0$  to  $t = T$  and a zero response thereafter. In a physical system, as already described, we achieve the effect of a zero response after  $t = T$  by sampling at  $t = T$ , so that so far as the determination of one bit is concerned we ignore the response after  $t = T$ .

## COHERENT RECEPTION: CORRELATION:

We discuss now an alternative type of receiving system which, as we shall see, is identical in performance with the matched filter receiver. Again, as shown in Fig. 11.6-1, the input is a binary data waveform  $s_1(t)$  or  $s_2(t)$  corrupted by noise  $n(t)$ . The bit length is  $T$ . The received signal plus noise  $v_A(t)$  is multiplied by a locally generated waveform  $s_1(t) - s_2(t)$ . The output of the multiplier is passed through an integrator whose output is sampled at  $t = T$ . As before, immediately after each sampling, at the beginning of each new bit interval, all energy-storing elements in the integrator are discharged. This type of receiver is called a *correlator*, since we are *correlating* the received signal and noise with the waveform  $s_1(t) - s_2(t)$ .

The output signal and noise of the correlator shown in Fig. 11.6-1 are

$$s_o(T) = \frac{1}{\tau} \int_0^T s_A(t)[s_1(t) - s_2(t)] dt \quad (11.6-1)$$



$$n_o(T) = \frac{1}{\tau} \int_0^T n(t)[s_1(t) - s_2(t)] dt \quad (11.6-2)$$

Where  $s_1(t)$  is either  $s_1(t)$  or  $s_2(t)$ , and where  $\pi$  is the constant of the integrator (i.e., the integrator output is  $1/\pi$  times the integral of its input). We now compare these outputs with the matched filter outputs.

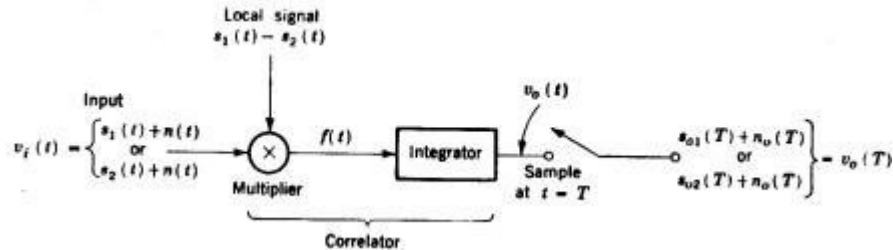

**Fig:11.6-1 Coherent system of signal reception**

If  $h(t)$  is the impulsive response of the matched filter, then the output of the matched filter  $v_o(t)$  can be found using the convolution integral. We have

$$v_o(t) = \int_{-\infty}^{\infty} v_i(\lambda)h(t - \lambda) d\lambda = \int_0^T v_i(\lambda)h(t - \lambda) d\lambda \quad (11.6-3)$$

The limits on the integral have been changed to 0 and T since we are interested in the filter response to a bit which extends only over that interval. Using Eq.(11.4-4) which gives  $h(t)$  for the matched filter, we have

$$h(t) = \frac{2K}{\eta} [s_1(T - t) - s_2(T - t)] \quad (11.6-4)$$

so that 
$$h(t - \lambda) = \frac{2K}{\eta} [s_1(T - t + \lambda) - s_2(T - t + \lambda)] \quad (11.6-5)$$

sub 11.6-5 in 11.6-3

$$v_o(t) = \frac{2K}{\eta} \int_0^T v_i(\lambda)[s_1(T - t + \lambda) - s_2(T - t + \lambda)] d\lambda \quad (11.6-6)$$

Since  $v_i(\lambda) = s_i(\lambda) + n(\lambda)$ , and  $v_o(t) = s_o(t) + n_o(t)$ , setting  $t = T$  yields

$$s_o(T) = \frac{2K}{\eta} \int_0^T s_i(\lambda)[s_1(\lambda) - s_2(\lambda)] d\lambda \quad (11.6-7)$$

where  $s_i(\lambda)$  is equal to  $s_1(\lambda)$  or  $s_2(\lambda)$ . Similarly we find that

$$n_o(T) = \frac{2K}{\eta} \int_0^T n(\lambda)[s_1(\lambda) - s_2(\lambda)] d\lambda \quad (11.6-8)$$

Thus  $s_o(T)$  and  $n_o(T)$ , as calculated from eqs.(11.6-1) and (11.6-2) for the correlation receiver, and as calculated from eqs.(11.6-7) and (11.6-8) for the matched filter receiver, are identical. Hence the performances of the two systems are identical. The matched filter and the correlator are not simply

two distinct, independent techniques which happens to yield the same result. In fact they are two techniques of synthesizing the optimum filter  $h(t)$

### 5.13.1 Error Probability of ASK

In Amplitude Shift Keying (ASK), some number of carrier cycles are transmitted to send '1' and no signal is transmitted for binary '0'. Thus,

$$\text{Binary '1'} \Rightarrow x_1(t) = \sqrt{2P_s} \cos(2\pi f_0 t) \text{ and}$$

$$\text{Binary '0'} \Rightarrow x_2(t) = 0 \text{ (i.e. no signal)} \quad \dots (5.13.1)$$

Here  $P_s$  is the normalized power of the signal in  $1\Omega$  load. i.e. power  $P_s = \frac{A^2}{2}$ .

Hence  $A = \sqrt{2P_s}$ . Therefore in above equation for  $x_1(t)$  amplitude 'A' is replaced by  $\sqrt{2P_s}$ .

We know that the probability of error of the optimum filter is given as,

$$P_e = \frac{1}{2} \operatorname{erfc} \left\{ \frac{x_{01}(T) - x_{02}(T)}{2\sqrt{2}\sigma} \right\} \quad \dots (5.13.2)$$

$$\text{Here } \left[ \frac{x_{01}(T) - x_{02}(T)}{\sigma} \right]_{\max}^2 = \int_{-\infty}^{\infty} \frac{|X(f)|^2}{S_{ni}(f)} df$$

The above equations can be applied to matched filter when we consider white Gaussian noise. The power spectral density of white Gaussian noise is given as,

$$S_{ni}(f) = \frac{N_0}{2}$$

Putting this value of  $S_{ni}(f)$  in above equations we get,

$$\begin{aligned} \left[ \frac{x_{01}(T) - x_{02}(T)}{\sigma} \right]_{\max}^2 &= \int_{-\infty}^{\infty} \frac{|X(f)|^2}{\frac{N_0}{2}} df \\ &= \frac{2}{N_0} \int_{-\infty}^{\infty} |X(f)|^2 df \quad \dots (5.13.3) \end{aligned}$$

Parseval's power theorem states that,

$$\int_{-\infty}^{\infty} |X(f)|^2 df = \int_{-\infty}^{\infty} x^2(t) dt$$

Hence equation 5.13.3 becomes,

$$\left[ \frac{x_{01}(T) - x_{02}(T)}{\sigma} \right]_{\max}^2 = \frac{2}{N_0} \int_{-\infty}^{\infty} x^2(t) dt$$

We know that  $x(t)$  is present from 0 to  $T$ . Hence limits in above equation can be changed as follows :

$$\left[ \frac{x_{01}(T) - x_{02}(T)}{\sigma} \right]_{\max}^2 = \frac{2}{N_0} \int_0^T x^2(t) dt \quad \dots (5.13.4)$$

We know that  $x(t) = x_1(t) - x_2(t)$ . For ASK  $x_2(t)$  is zero, hence  $x(t) = x_1(t)$ . Hence above equation becomes,

$$\left[ \frac{x_{01}(T) - x_{02}(T)}{\sigma} \right]_{\max}^2 = \frac{2}{N_0} \int_0^T x_1^2(t) dt$$

Putting equation of  $x_1(t)$  from equation 5.13.1 in above equation we get,

$$\begin{aligned} \left[ \frac{x_{01}(T) - x_{02}(T)}{\sigma} \right]_{\max}^2 &= \frac{2}{N_0} \int_0^T \left[ \sqrt{2P_s} \cos(2\pi f_0 t) \right]^2 dt \\ &= \frac{4P_s}{N_0} \int_0^T \cos^2(2\pi f_0 t) dt \end{aligned}$$

We know that  $\cos^2 \theta = \frac{1 + \cos 2\theta}{2}$ . Here applying this formula to  $\cos^2(2\pi f_0 t)$  we get,

$$\begin{aligned} \left[ \frac{x_{01}(T) - x_{02}(T)}{\sigma} \right]_{\max}^2 &= \frac{4P_s}{N_0} \int_0^T \frac{1 + \cos 4\pi f_0 t}{2} dt \\ &= \frac{4P_s}{N_0} \cdot \frac{1}{2} \left\{ \int_0^T dt + \int_0^T \cos 4\pi f_0 t dt \right\} \\ &= \frac{2P_s}{N_0} \left\{ [t]_0^T + \left[ \frac{\sin 4\pi f_0 t}{4\pi f_0} \right]_0^T \right\} \\ &= \frac{2P_s}{N_0} \left\{ T + \frac{\sin 4\pi f_0 T}{4\pi f_0} \right\} \quad \dots (5.13.5) \end{aligned}$$

We know that  $T$  is the bit period and in this one bit period, the carrier has integer number of cycles. Thus the product  $f_0 T$  is an integer. This is illustrated in Fig. 5.13.1

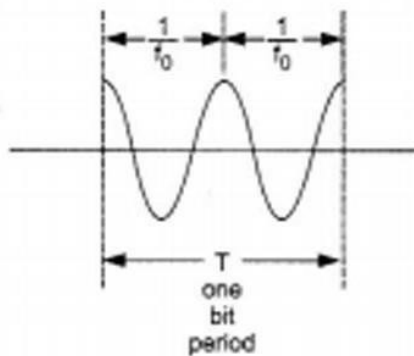

Fig. 5.13.1 In one bit period  $T$ , the carrier completes its two cycles. The carrier has frequency  $f_0$ . From figure we can write,

$$T = \frac{1}{f_0} + \frac{1}{f_0}$$

$$\text{i.e. } T = \frac{2}{f_0}$$

$$\therefore f_0 T = 2 \quad (\text{integer no. of cycles})$$

As shown in above figure, the carrier completes two cycles in one bit duration. Hence

$$f_0 T = 2$$

Therefore, in general if carrier completes 'k' number of cycles, then,

$$f_0 T = k \quad (\text{Here } k \text{ is an integer})$$

Therefore the sine term in equation 5.13.5 becomes,  $\sin 4\pi k$  and  $k$  is integer.

For all integer values of  $k$ ,  $\sin 4\pi k = 0$ . Hence equation 5.13.5 becomes,

$$\left[ \frac{x_{01}(T) - x_{02}(T)}{\sigma} \right]_{\max}^2 = \frac{2P_s T}{N_0} \quad \dots (5.13.6)$$

$$\therefore \left[ \frac{x_{01}(T) - x_{02}(T)}{\sigma} \right]_{\max} = \sqrt{\frac{2P_s T}{N_0}} \quad \dots (5.13.7)$$

Putting this value in equation 5.13.2 we get error probability of ASK using matched filter detection as,

$$P_e = \frac{1}{2} \operatorname{erfc} \left\{ \frac{1}{2\sqrt{2}} \cdot \sqrt{\frac{2P_s T}{N_0}} \right\} = \frac{1}{2} \operatorname{erfc} \sqrt{\frac{P_s T}{4N_0}}$$

Here  $P_s T = E$ , i.e. energy of one bit hence above equation becomes,

$$\boxed{\text{Error probability of ASK : } P_e = \frac{1}{2} \operatorname{erfc} \sqrt{\frac{E}{4N_0}}} \quad \dots (5.13.8)$$

This is the expression for error probability of ASK using matched filter detection.

## Error Probability of Binary FSK

The observation vector  $\mathbf{x}$  has two elements  $x_1$  and  $x_2$  that are defined by, respectively,

$$x_1 = \int_0^{T_b} x(t)\phi_1(t) dt \quad (6.92)$$

$$x_2 = \int_0^{T_b} x(t)\phi_2(t) dt \quad (6.93)$$

where  $x(t)$  is the received signal, the form of which depends on which symbol was transmitted. Given that symbol 1 was transmitted,  $x(t)$  equals  $s_1(t) + w(t)$ , where  $w(t)$  is the sample function of a white Gaussian noise process of zero mean and power spectral density  $N_0/2$ . If, on the other hand, symbol 0 was transmitted,  $x(t)$  equals  $s_2(t) + w(t)$ .

Now, applying the decision rule of Equation (5.59), we find that the observation space is partitioned into two decision regions, labeled  $Z_1$  and  $Z_2$  in Figure 6.25. The decision boundary, separating region  $Z_1$  from region  $Z_2$  is the perpendicular bisector of

the line joining the two message points. The receiver decides in favor of symbol 1 if the received signal point represented by the observation vector  $\mathbf{x}$  falls inside region  $Z_1$ . This occurs when  $x_1 > x_2$ . If, on the other hand, we have  $x_1 < x_2$ , the received signal point falls inside region  $Z_2$ , and the receiver decides in favor of symbol 0. On the decision boundary, we have  $x_1 = x_2$ , in which case the receiver makes a random guess in favor of symbol 1 or 0.

Define a new Gaussian random variable  $Y$  whose sample value  $y$  is equal to the difference between  $x_1$  and  $x_2$ ; that is,

$$y = x_1 - x_2 \quad (6.94)$$

The mean value of the random variable  $Y$  depends on which binary symbol was transmitted. Given that symbol 1 was transmitted, the Gaussian random variables  $X_1$  and  $X_2$ , whose sample values are denoted by  $x_1$  and  $x_2$ , have mean values equal to  $\sqrt{E_b}$  and zero, respectively. Correspondingly, the conditional mean of the random variable  $Y$ , given that symbol 1 was transmitted, is

$$\begin{aligned} E[Y|1] &= E[X_1|1] - E[X_2|1] \\ &= +\sqrt{E_b} \end{aligned} \quad (6.95)$$

On the other hand, given that symbol 0 was transmitted, the random variables  $X_1$  and  $X_2$  have mean values equal to zero and  $\sqrt{E_b}$ , respectively. Correspondingly, the conditional mean of the random variable  $Y$ , given that symbol 0 was transmitted, is

$$\begin{aligned} E[Y|0] &= E[X_1|0] - E[X_2|0] \\ &= -\sqrt{E_b} \end{aligned} \quad (6.96)$$

The variance of the random variable  $Y$  is independent of which binary symbol was transmitted. Since the random variables  $X_1$  and  $X_2$  are statistically independent, each with a variance equal to  $N_0/2$ , it follows that

$$\begin{aligned} \text{var}[Y] &= \text{var}[X_1] + \text{var}[X_2] \\ &= N_0 \end{aligned} \quad (6.97)$$

Suppose we know that symbol 0 was transmitted. The conditional probability density function of the random variable  $Y$  is then given by

$$f_Y(y|0) = \frac{1}{\sqrt{2\pi N_0}} \exp\left[-\frac{(y + \sqrt{E_b})^2}{2N_0}\right] \quad (6.98)$$

Since the condition  $x_1 > x_2$ , or equivalently,  $y > 0$ , corresponds to the receiver making a decision in favor of symbol 1, we deduce that the conditional probability of error, given that symbol 0 was transmitted, is

$$\begin{aligned} p_{10} &= P(y > 0 | \text{symbol 0 was sent}) \\ &= \int_0^{\infty} f_Y(y|0) dy \\ &= \frac{1}{\sqrt{2\pi N_0}} \int_0^{\infty} \exp\left[-\frac{(y + \sqrt{E_b})^2}{2N_0}\right] dy \end{aligned} \quad (6.99)$$

$$\frac{y + \sqrt{E_b}}{\sqrt{2N_0}} = z \quad (6.100)$$

Then, changing the variable of integration from  $y$  to  $z$ , we may rewrite Equation (6.99) as follows:

$$\begin{aligned} p_{10} &= \frac{1}{\sqrt{\pi}} \int_{\sqrt{E_b/2N_0}}^{\infty} \exp(-z^2) dz \\ &= \frac{1}{2} \text{erfc}\left(\sqrt{\frac{E_b}{2N_0}}\right) \end{aligned} \quad (6.101)$$

Similarly, we may show the  $p_{01}$ , the conditional probability of error given that symbol 1 was transmitted, has the same value as in Equation (6.101). Accordingly, averaging  $p_{10}$  and  $p_{01}$ , we find that the *average probability of bit error* or, equivalently, the *bit error rate for coherent binary FSK* is (assuming equiprobable symbols)

$$P_e = \frac{1}{2} \operatorname{erfc}\left(\sqrt{\frac{E_b}{2N_0}}\right) \quad (6.102)$$

Comparing Equations (6.20) and (6.102), we see that, in a coherent binary FSK system, we have to double the *bit energy-to-noise density ratio*,  $E_b/N_0$ , to maintain the same bit error rate as in a coherent binary PSK system. This result is in perfect accord with the signal-space diagrams of Figures 6.3 and 6.25, where we see that in a binary PSK system the Euclidean distance between the two message points is equal to  $2\sqrt{E_b}$ , whereas in a binary FSK system the corresponding distance is  $\sqrt{2E_b}$ . For a prescribed  $E_b$ , the minimum distance  $d_{\min}$  in binary PSK is therefore  $\sqrt{2}$  times that in binary FSK. Recall from Chapter 5 that the probability of error decreases exponentially as  $d_{\min}^2$ , hence the difference between the formulas of Equations (6.20) and (6.102).

### **Error Probability of QPSK**

In a coherent QPSK system, the received signal  $x(t)$  is defined by

$$x(t) = s_i(t) + w(t), \quad \begin{cases} 0 \leq t \leq T \\ i = 1, 2, 3, 4 \end{cases} \quad (6.28)$$

where  $w(t)$  is the sample function of a white Gaussian noise process of zero mean and power spectral density  $N_0/2$ . Correspondingly, the observation vector  $\mathbf{x}$  has two elements,  $x_1$  and  $x_2$ , defined by

$$\begin{aligned} x_1 &= \int_0^T x(t) \phi_1(t) dt \\ &= \sqrt{E} \cos\left[(2i-1) \frac{\pi}{4}\right] + w_1 \\ &= \pm \sqrt{\frac{E}{2}} + w_1 \end{aligned} \quad (6.29)$$



$$\begin{aligned}
x_2 &= \int_0^T x(t)\phi_2(t) dt \\
&= -\sqrt{E} \sin\left[(2i-1)\frac{\pi}{4}\right] + w_2 \\
&= \mp\sqrt{\frac{E}{2}} + w_2
\end{aligned} \tag{6.30}$$

Thus the observable elements  $x_1$  and  $x_2$  are sample values of independent Gaussian random variables with mean values equal to  $\pm\sqrt{E/2}$  and  $\mp\sqrt{E/2}$ , respectively, and with a common variance equal to  $N_0/2$ .

The decision rule is now simply to decide that  $s_1(t)$  was transmitted if the received signal point associated with the observation vector  $\mathbf{x}$  falls inside region  $Z_1$ , decide that  $s_2(t)$  was transmitted if the received signal point falls inside region  $Z_2$ , and so on. An erroneous decision will be made if, for example, signal  $s_4(t)$  is transmitted but the noise  $w(t)$  is such that the received signal point falls outside region  $Z_4$ .

To calculate the average probability of symbol error, we note from Equation (6.24) that a coherent QPSK system is in fact equivalent to two coherent binary PSK systems working in parallel and using two carriers that are in phase quadrature; this is merely a statement of the quadrature-carrier multiplexing property of coherent QPSK. The in-phase channel output  $x_1$  and the quadrature channel output  $x_2$  (i.e., the two elements of the observation vector  $\mathbf{x}$ ) may be viewed as the individual outputs of the two coherent binary PSK systems. Thus, according to Equations (6.29) and (6.30), these two binary PSK systems may be characterized as follows:

- ▶ The signal energy per bit is  $E/2$ .
- ▶ The noise spectral density is  $N_0/2$ .

Hence, using Equation (6.20) for the average probability of bit error of a coherent binary PSK system, we may now state that the average probability of bit error in *each* channel of the coherent QPSK system is

$$\begin{aligned}
P' &= \frac{1}{2} \operatorname{erfc}\left(\sqrt{\frac{E/2}{N_0}}\right) \\
&= \frac{1}{2} \operatorname{erfc}\left(\sqrt{\frac{E}{2N_0}}\right)
\end{aligned} \tag{6.31}$$

Another important point to note is that the bit errors in the in-phase and quadrature channels of the coherent QPSK system are statistically independent. The in-phase channel makes a decision on one of the two bits constituting a symbol (dibit) of the QPSK signal, and the quadrature channel takes care of the other bit. Accordingly, the *average probability of a correct decision* resulting from the combined action of the two channels working together is

$$\begin{aligned}
 P_c &= (1 - P')^2 \\
 &= \left[ 1 - \frac{1}{2} \operatorname{erfc}\left(\sqrt{\frac{E}{2N_0}}\right) \right]^2 \\
 &= 1 - \operatorname{erfc}\left(\sqrt{\frac{E}{2N_0}}\right) + \frac{1}{4} \operatorname{erfc}^2\left(\sqrt{\frac{E}{2N_0}}\right)
 \end{aligned} \tag{6.32}$$

The average probability of symbol error for coherent QPSK is therefore

$$\begin{aligned}
 P_e &= 1 - P_c \\
 &= \operatorname{erfc}\left(\sqrt{\frac{E}{2N_0}}\right) - \frac{1}{4} \operatorname{erfc}^2\left(\sqrt{\frac{E}{2N_0}}\right)
 \end{aligned} \tag{6.33}$$

In the region where  $(E/2N_0) \gg 1$ , we may ignore the quadratic term on the right-hand side of Equation (6.33), so we approximate the formula for the average probability of symbol error for coherent QPSK as

$$P_e \approx \operatorname{erfc}\left(\sqrt{\frac{E}{2N_0}}\right) \tag{6.34}$$

The formula of Equation (6.34) may also be derived in another insightful way, using the signal-space diagram of Figure 6.6. Since the four message points of this diagram are circularly symmetric with respect to the origin, we may apply Equation (5.92), reproduced here in the form

$$P_e \leq \frac{1}{2} \sum_{\substack{k=1 \\ k \neq i}}^4 \operatorname{erfc}\left(\frac{d_{ik}}{2\sqrt{N_0}}\right) \quad \text{for all } i \tag{6.35}$$

Consider, for example, message point  $m_1$  (corresponding to dibit 10) chosen as the transmitted message point. The message points  $m_2$  and  $m_4$  (corresponding to dibits 00 and 11) are the *closest* to  $m_1$ . From Figure 6.6 we readily find that  $m_1$  is equidistant from  $m_2$  and  $m_4$  in a Euclidean sense, as shown by

$$d_{12} = d_{14} = \sqrt{2E}$$

Assuming that  $E/N_0$  is large enough to ignore the contribution of the most distant message point  $m_3$  (corresponding to dibit 01) relative to  $m_1$ , we find that the use of Equation (6.35) yields an approximate expression for  $P_e$  that is the same as Equation (6.34). Note that in mistaking either  $m_2$  or  $m_4$  for  $m_1$ , a single bit error is made; on the other hand, in mistaking  $m_3$  for  $m_1$ , two bit errors are made. For a high enough  $E/N_0$ , the likelihood of both bits of a symbol being in error is much less than a single bit, which is a further justification for ignoring  $m_3$  in calculating  $P_e$  when  $m_1$  is sent.

In a QPSK system, we note that since there are two bits per symbol, the transmitted signal energy per symbol is twice the signal energy per bit, as shown by

$$E = 2E_b \quad (6.36)$$

Thus expressing the average probability of symbol error in terms of the ratio  $E_b/N_0$ , we may write

$$P_e \approx \text{erfc}\left(\sqrt{\frac{E_b}{N_0}}\right) \quad (6.37)$$

With Gray encoding used for the incoming symbols, we find from Equations (6.31) and (6.36) that the *bit error rate* of QPSK is exactly

$$\text{BER} = \frac{1}{2} \text{erfc}\left(\sqrt{\frac{E_b}{N_0}}\right) \quad (6.38)$$

We may therefore state that a coherent QPSK system achieves the same average probability of bit error as a coherent binary PSK system for the same bit rate and the same  $E_b/N_0$ , but uses only half the channel bandwidth. Stated in a different way, for the same  $E_b/N_0$  and therefore the same average probability of bit error, a coherent QPSK system transmits information at twice the bit rate of a coherent binary PSK system for the same channel

bandwidth. For a prescribed performance, QPSK uses channel bandwidth better than binary PSK, which explains the preferred use of QPSK over binary PSK in practice.

## ERROR PROBABILITY OF BINARY PSK:

To realize a rule for making a decision in favor of symbol 1 or symbol 0, we partition the signal space into two regions:

- ▶ The set of points closest to message point 1 at  $+\sqrt{E_b}$ .
- ▶ The set of points closest to message point 2 at  $-\sqrt{E_b}$ .

This is accomplished by constructing the midpoint of the line joining these two message points, and then marking off the appropriate decision regions. In Figure 6.3 these decision regions are marked  $Z_1$  and  $Z_2$ , according to the message point around which they are constructed.

The decision rule is now simply to decide that signal  $s_1(t)$  (i.e., binary symbol 1) was transmitted if the received signal point falls in region  $Z_1$ , and decide that signal  $s_2(t)$  (i.e., binary symbol 0) was transmitted if the received signal point falls in region  $Z_2$ . Two kinds of erroneous decisions may, however, be made. Signal  $s_2(t)$  is transmitted, but the noise is such that the received signal point falls inside region  $Z_1$  and so the receiver decides in favor of signal  $s_1(t)$ . Alternatively, signal  $s_1(t)$  is transmitted, but the noise is such that the received signal point falls inside region  $Z_2$  and so the receiver decides in favor of signal  $s_2(t)$ .

To calculate the probability of making an error of the first kind, we note from Figure 6.3 that the decision region associated with symbol 1 or signal  $s_1(t)$  is described by

$$Z_1: 0 < x_1 < \infty$$

where the observable element  $x_1$  is related to the received signal  $x(t)$  by

$$x_1 = \int_0^{T_b} x(t)\phi_1(t) dt \quad (6.15)$$

The conditional probability density function of random variable  $X_1$ , given that symbol 0 [i.e., signal  $s_2(t)$ ] was transmitted, is defined by

$$\begin{aligned} f_{X_1}(x_1|0) &= \frac{1}{\sqrt{\pi N_0}} \exp\left[-\frac{1}{N_0} (x_1 - s_{21})^2\right] \\ &= \frac{1}{\sqrt{\pi N_0}} \exp\left[-\frac{1}{N_0} (x_1 + \sqrt{E_b})^2\right] \end{aligned} \quad (6.16)$$

The conditional probability of the receiver deciding in favor of symbol 1, given that symbol 0 was transmitted, is therefore

$$\begin{aligned} p_{10} &= \int_0^{\infty} f_{X_1}(x_1|0) dx_1 \\ &= \frac{1}{\sqrt{\pi N_0}} \int_0^{\infty} \exp\left[-\frac{1}{N_0} (x_1 + \sqrt{E_b})^2\right] dx_1 \end{aligned} \quad (6.17)$$

Putting

$$z = \frac{1}{\sqrt{N_0}} (x_1 + \sqrt{E_b}) \quad (6.18)$$

and changing the variable of integration from  $x_1$  to  $z$ , we may rewrite Equation (6.17) in the compact form

$$\begin{aligned} p_{10} &= \frac{1}{\sqrt{\pi}} \int_{\sqrt{E_b/N_0}}^{\infty} \exp(-z^2) dz \\ &= \frac{1}{2} \operatorname{erfc}\left(\sqrt{\frac{E_b}{N_0}}\right) \end{aligned} \quad (6.19)$$

where  $\operatorname{erfc}(\cdot)$  is the complementary error function.

Thus, averaging the conditional error probabilities  $p_{10}$  and  $p_{01}$ , we find that the *average probability of symbol error* or, equivalently, the *bit error rate for coherent binary PSK* is (assuming equiprobable symbols)

$$P_e = \frac{1}{2} \operatorname{erfc}\left(\sqrt{\frac{E_b}{N_0}}\right) \quad (6.20)$$

As we increase the transmitted signal energy per bit,  $E_b$ , for a specified noise spectral density  $N_0$ , the message points corresponding to symbols 1 and 0 move further apart, and the average probability of error  $P_e$  is correspondingly reduced in accordance with Equation (6.20), which is intuitively satisfying.

# **UNIT III**

## **Information Theory & Source Coding**

# Contents

## Information Theory:

- Discrete messages
- Concept of amount of information and its properties
- Average information
- Entropy and its properties
- Information rate
- Mutual information and its properties
- Illustrative Problems

## Source Coding:

- Introduction
- Advantages
- Hartley Shannon's theorem
- Bandwidth –S/N trade off
- Shanon- Fano coding,
- Huffman coding
- Illustrative Problems

## Information Theory

Information theory deals with representation and the transfer of information.

There are two fundamentally different ways to transmit **messages**: via **discrete** signals and via continuous signals..... For example, the letters of the English alphabet are commonly thought of as **discrete** signals.

### Information sources

#### Definition:

The set of source symbols is called the **source alphabet**, and the elements of the set are called the **symbols or letters**.

The number of possible answers ' r ' should be linked to "information."

"Information" should be additive in some sense.

We define the following measure of information:

$$\tilde{I}(U) \triangleq \log_b r,$$

Where ' r ' is the number of all possible outcome so far an do m message U.

Using this definition we can confirm that it has the wanted property of additivity:

$$\tilde{I}(U_1, U_2, \dots, U_n) = \log_b r^n = n \cdot \log_b r = n\tilde{I}(U).$$

The basis 'b' of the logarithm b is only a change of units without actually changing the amount of information it describes.

### Classification of information sources

1. Discrete memory less.
2. Memory.

Discrete memory less source (DMS) can be characterized by "the list of the symbols, the probability assignment to these symbols, and the specification of the rate of generating these symbols by the source".

1. Information should be proportion to the uncertainty of an outcome.
2. Information contained in independent outcome should add.

### Scope of Information Theory

1. Determine the irreducible limit below which a signal cannot be compressed.
2. Deduce the ultimate transmission rate for reliable communication over a noisy channel.
3. Define Channel Capacity - the intrinsic ability of a channel to convey information.



The basic setup in Information Theory has:

- a source,
- a channel and
- destination.

The output from source is conveyed through the channel and received at the destination.

The source is a random variable  $S$

which takes symbols from a finite alphabet i.e.,

$$S = \{s_0, s_1, s_2, \dots, s_{k-1}\}$$

With probabilities

$$P(S = s_k) = p_k \text{ where } k = 0, 1, 2, \dots, k-1$$

and

$$\sum_{k=0}^{k-1} p_k = 1$$

The following assumptions are made about the source

1. Source generates symbols that are statistically independent.
2. Source is memory less i.e., the choice of present symbol does not depend on the previous choices.

### **Properties of Information**

1. Information conveyed by a deterministic event is nothing
2. Information is always positive.
3. Information is never lost.
4. More information is conveyed by a less probable event than a more probable event

### **Entropy:**

The Entropy ( $H(s)$ ) of a source is defined as the average information generated by a discrete memory less source.

### Information content of a symbol:

Let us consider a discrete memory less source (DMS) denoted by X and having the alphabet  $\{U_1, U_2, U_3, \dots, U_m\}$ . The information content of the symbol  $x_i$ , denoted by  $I(x_i)$  is defined as

$$I(U) = \log_b \frac{1}{P(u)} = -\log_b P(U)$$

Where  $P(U)$  is the probability of occurrence of symbol U

Units of  $I(x_i)$ :

For two important and one unimportant special cases of b it has been agreed to use the following names for these units:

$b=2(\log 2)$ : bit,

$b=e(\ln)$ : nat (natural logarithm),

$b=10(\log 10)$ : Hartley.

The conversion of these units to other units is given as

$$\log_2 a = \frac{\ln a}{\ln 2} = \frac{\log a}{\log 2}$$

### Uncertainty or Entropy (i.e Average information)

#### Definition:

In order to get the information content of the symbol, the flow information on the symbol can fluctuate widely because of randomness involved into the selection of symbols.

The uncertainty or entropy of a discrete random variable (RV) 'U' is defined as

$$H(U) = E[I(u)] = \sum_{i=1}^m P(u) I(u)$$

$$H(U) \triangleq - \sum_{u \in \text{supp}(P_U)} P_U(u) \log_b P_U(u),$$

Where  $P_U(\cdot)$  denotes the probability mass function (PMF) of the RV  $U$ , and where the support of  $P_U$  is defined as

$$\text{supp}(P_U) \triangleq \{u \in \mathcal{U} : P_U(u) \neq 0\}.$$

We will usually neglect to mention “support” when we sum over  $P_U(u) \cdot \log_b P_U(u)$ , i.e., we implicitly assume that we exclude all  $u$

With zero probability  $P_U(u) = 0$ .

### Entropy for binary source

It may be noted that for a binary source  $U$  which generates independent symbols 0 and 1 with equal probability, the source entropy  $H(u)$  is

$$H(u) = -\frac{1}{2} \log_2 \frac{1}{2} - \frac{1}{2} \log_2 \frac{1}{2} = 1 \text{ b/symbol}$$

### Bounds on $H(U)$

If  $U$  has  $r$  possible values, then  $0 \leq H(U) \leq \log r$ ,

Where

$H(U) = 0$  if, and only if,  $P_U(u) = 1$  for some  $u$ ,

$H(U) = \log r$  if, and only if,  $P_U(u) = 1/r \forall u$ .

Hence,  $H(U) \geq 0$ . Equality can only be achieved if  $-P_U(u) \log_2 P_U(u) = 0$

*Proof.* Since  $0 \leq P_U(u) \leq 1$ , we have

$$-P_U(u) \log_2 P_U(u) \begin{cases} = 0 & \text{if } P_U(u) = 1, \\ > 0 & \text{if } 0 < P_U(u) < 1. \end{cases}$$

For all  $u \in \text{supp}(P_U)$ , i.e.,  $P_U(u) = 1$  for all  $u \in \text{supp}(P_U)$ .

To derive the upper bound we use a trick that is quite common in

Information theory: We take the derivative and try to show that it must be non positive.

$$\begin{aligned}
H(U) - \log r &= - \sum_{u \in \text{supp}(P_U)} P_U(u) \log P_U(u) - \log r \\
&= - \sum_{u \in \text{supp}(P_U)} P_U(u) \log P_U(u) - \sum_{u \in \text{supp}(P_U)} P_U(u) \log r \\
&= - \sum_{u \in \text{supp}(P_U)} P_U(u) \log (P_U(u) \cdot r) \\
&= \sum_{u \in \text{supp}(P_U)} P_U(u) \log \underbrace{\left( \frac{1}{r \cdot P_U(u)} \right)}_{\triangleq \xi} \\
&\leq \sum_{u \in \text{supp}(P_U)} P_U(u) \left( \frac{1}{r \cdot P_U} - 1 \right) \cdot \log e \\
&= \left( \sum_{u \in \text{supp}(P_U)} \frac{1}{r} - \underbrace{\sum_{u \in \text{supp}(P_U)} P_U(u)}_{=1} \right) \cdot \log e \\
&= \left( \frac{1}{r} \sum_{u \in \text{supp}(P_U)} 1 - 1 \right) \log e \\
&\leq \left( \frac{1}{r} \sum_{u \in \mathcal{U}} 1 - 1 \right) \log e \\
&= \left( \frac{1}{r} \cdot r - 1 \right) \log e \\
&= (1 - 1) \log e = 0.
\end{aligned}$$

Equality can only be achieved if

1. In the IT Inequality  $\xi = 1$ , i.e., if  $1/r \cdot P_U(u) = 1 \Rightarrow P_U(u) = 1/r$ , for all  $u$ ;
2.  $|\text{supp}(P_U)| = r$ .

Note that if Condition 1 is satisfied, Condition 2 is also satisfied.

## Conditional Entropy

Similar to probability of random vectors, there is nothing really new about conditional probabilities given that a particular event  $Y = y$  has occurred.

The conditional entropy or conditional uncertainty of the RV  $X$  given the event  $Y = y$  is defined as

$$\begin{aligned} H(X|Y = y) &\triangleq - \sum_{x \in \text{supp}(P_{X|Y}(\cdot|y))} P_{X|Y}(x|y) \log P_{X|Y}(x|y) \\ &= E[-\log P_{X|Y}(X|Y) | Y = y]. \end{aligned}$$

Note that the definition is identical to before apart from that everything is conditioned on the event  $Y = y$

$$\begin{aligned} 0 &\leq H(X|Y = y) \leq \log r; \\ H(X|Y = y) = 0 &\text{ if, and only if, } P(x|y) = 1 \text{ for some } x; \\ H(X|Y = y) = \log r &\text{ if, and only if, } P(x|y) = \frac{1}{r} \quad \forall x. \end{aligned}$$

Note that the conditional entropy given the event  $Y = y$  is a function of  $y$ . Since  $Y$  is also a RV, we can now average over all possible events  $Y = y$  according to the probabilities of each event. This will lead to the averaged.

## Mutual Information

Although conditional entropy can tell us when two variables are completely independent, it is not an adequate measure of dependence. A small value for  $H(Y|X)$  may imply that  $X$  tells us a great deal about  $Y$  or that  $H(Y)$  is small to begin with. Thus, we measure dependence using *mutual information*:

$$I(X, Y) = H(Y) - H(Y|X)$$

Mutual information is a measure of the reduction of randomness of a variable given knowledge of another variable. Using properties of logarithms, we can derive several equivalent definitions

$$I(X,Y)=H(X)-H(X|Y)$$

$$I(X,Y) = H(X)+H(Y)-H(X,Y) = I(Y,X)$$

In addition to the definitions above, it is useful to realize that mutual information is a particular case of the Kullback-Leibler divergence. The KL divergence is defined as:

$$D(p||q) = \int p(x) \log \frac{p(x)}{q(x)}$$

KL divergence measures the difference between two distributions. It is sometimes called the relative entropy. It is always non-negative and zero only when  $p=q$ ; however, it is not a distance because it is not symmetric.

In terms of KL divergence, mutual information is:

$$D(P(X, Y)||P(X)P(Y)) = \int P(X, Y) \log \frac{P(X, Y)}{P(X)P(Y)}$$

In other words, mutual information is a measure of the difference between the joint probability and product of the individual probabilities. These two distributions are equivalent only when  $X$  and  $Y$  are independent, and diverge as  $X$  and  $Y$  become more dependent.

## Source coding

Coding theory is the study of the properties of codes and their respective fitness for specific applications. Codes are used for data compression, cryptography, error-correction, and networking. Codes are studied by various scientific disciplines—such as information theory, electrical engineering, mathematics, linguistics, and computer science—for the purpose of designing efficient and reliable data transmission methods. This typically involves the removal of redundancy and the correction or detection of errors in the transmitted data.

The aim of source coding is to take the source data and make it smaller.

All source models in information theory may be viewed as random process or random sequence models. Let us consider the example of a discrete memory less source (DMS), which is a simple random sequence model.

A DMS is a source whose output is a sequence of letters such that each letter is independently selected from a fixed alphabet consisting of letters; say  $a_1, a_2,$

..... $a_k$ . The letters in the source output sequence are assumed to be random and statistically

Independent of each other. A fixed probability assignment for the occurrence of each letter is also assumed. Let us, consider a small example to appreciate the importance of probability assignment of the source letters.

Let us consider a source with four letters  $a_1$ ,  $a_2$ ,  $a_3$  and  $a_4$  with  $P(a_1)=0.5$ ,  $P(a_2)=0.25$ ,  $P(a_3)=0.13$ ,  $P(a_4)=0.12$ . Let us decide to go for binary coding of these four

Source letters While this can be done in multiple ways, two encoded representations are shown below:

*Code Representation#1:*

$a_1: 00$ ,  $a_2: 01$ ,  $a_3: 10$ ,  $a_4: 11$

*Code Representation#2:*

$a_1: 0$ ,  $a_2: 10$ ,  $a_3: 001$ ,  $a_4: 110$

It is easy to see that in method #1 the probability assignment of a source letter has not been considered and all letters have been represented by two bits each. However in

The second method only  $a_1$  has been encoded in one bit,  $a_2$  in two bits and the remaining two in three bits. It is easy to see that the average number of bits to be used per source letter for the two methods is not the same. ( $\bar{n}$  for method #1=2 bits per letter and  $\bar{n}$  for method #2 < 2 bits per letter). So, if we consider the issue of encoding a long sequence of

Letters we have to transmit less number of bits following the second method. This is an important aspect of source coding operation in general. At this point, let us note

a) We observe that assignment of small number of bits to more probable letters and assignment of larger number of bits to less probable letters (or symbols) may lead to efficient source encoding scheme.

b) However, one has to take additional care while transmitting the encoded letters. A careful inspection of the binary representation of the symbols in method #2 reveals that it may lead to confusion (at the decoder end) in deciding the end of binary representation of a letter and beginning of the subsequent letter.

So a source-encoding scheme should ensure that

- 1) The average number of coded bits (or letters in general) required per source letter is as small as possible and
- 2) The source letters can be fully retrieved from a received encoded sequence.



## Shannon-Fano Code

Shannon-Fano coding, named after Claude Elwood Shannon and Robert Fano, is a technique for constructing a prefix code based on a set of symbols and their probabilities. It is suboptimal in the sense that it does not achieve the lowest possible expected codeword length like Huffman coding; however unlike Huffman coding, it does guarantee that all codeword lengths are within one bit of their theoretical ideal  $I(x) = -\log P(x)$ .

In Shannon-Fano coding, the symbols are arranged in order from most probable to least probable, and then divided into two sets whose total probabilities are as close as possible to being equal. All symbols then have the first digits of their codes assigned; symbols in the first set receive "0" and symbols in the second set receive "1". As long as any sets with more than one member remain, the same process is repeated on those sets, to determine successive digits of their codes. When a set has been reduced to one symbol, of course, this means the symbol's code is complete and will not form the prefix of any other symbol's code.

The algorithm works, and it produces fairly efficient variable-length encodings; when the two smaller sets produced by a partitioning are in fact of equal probability, the one bit of information used to distinguish them is used most efficiently. Unfortunately, Shannon-Fano does not always produce optimal prefix codes.

For this reason, Shannon-Fano is almost never used; Huffman coding is almost as computationally simple and produces prefix codes that always achieve the lowest expected code word length. Shannon-Fano coding is used in the IMplode compression method, which is part of the ZIP file format, where it is desired to apply a simple algorithm with high performance and minimum requirements for programming.

### Shannon-Fano Algorithm:

A Shannon-Fano tree is built according to a specification designed to define an effective code table. The actual algorithm is simple:

For a given list of symbols, develop a corresponding list of probabilities or frequency counts so that each symbol's relative frequency of occurrence is known.

- Sort the lists of symbols according to frequency, with the most frequently occurring  
Symbols at the left and the least common at the right.
- Divide the list into two parts, with the total frequency counts of the left part being as  
Close to the total of the right as possible.
- The left part of the list is assigned the binary digit 0, and the right part is assigned  
the digit 1. This means that the codes for the symbols in the first part will all start  
with 0, and the codes in the second part will all start with 1.

Recursively apply the steps 3 and 4 to each of the two halves, subdividing groups  
and adding bits to the codes until each symbol has become a corresponding code leaf  
on the tree.

### Example:

The source of information A generates the symbols {A0, A1, A2, A3 and A4} with the  
corresponding probabilities {0.4, 0.3, 0.15, 0.1 and 0.05}. Encoding the source symbols  
using binary encoder and Shannon-Fano encoder gives

Source Symbol	P <sub>i</sub>	Binary Code	Shannon-Fano
A0	0.4	000	0
A1	0.3	001	10
A2	0.15	010	110
A3	0.1	011	1110
A4	0.05	100	1111
L <sub>avg</sub>	H = 2.0087	3	2.05

The average length of the Shannon-Fano code is

$$L_{avg} = \sum_{i=0}^4 P_i l_i = 0.4 * 1 + 0.3 * 2 + 0.15 * 3 + 0.1 * 4 + 0.05 * 4 = 2.05 \text{ bit/symbol}$$

Thus the efficiency of the Shannon-Fano code is

$$\eta = \frac{H}{L_{avg}} = \frac{2.0087}{2.05} = 98\%$$

This example demonstrates that the efficiency of the Shannon-Fano encoder is much higher than that of the binary encoder.

Shanon-Fano code is a top-down approach. Constructing the code tree, we get

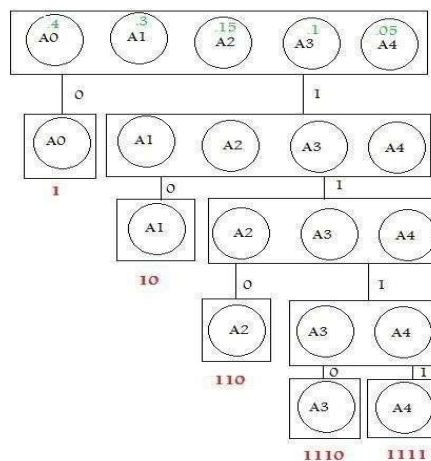

The Entropy of the source is

$$H = - \sum_{i=0}^4 P_i \log_2 P_i = 2.0087 \text{ bit/symbol}$$

Since we have 5 symbols ( $5 < 8 = 2^3$ ), we need 3 bits at least to represent each symbol in binary (fixed-length code). Hence the average length of the binary code is

$$L_{avg} = \sum_{i=0}^4 P_i l_i = 3 (0.4 + 0.3 + 0.15 + 0.1 + 0.05) = 3 \text{ bit/symbol}$$

Thus the efficiency of the binary code is

$$\eta = \frac{H}{L_{avg}} = \frac{2.0087}{3} = 67\%$$

**Binary Huffman Coding** (an optimum variable-length source coding scheme)

In Binary Huffman Coding each source letter is converted into a binary code word. It is a prefix condition code ensuring minimum average length per source letter in bits.

Let the source letters  $a_1, a_2, \dots, a_K$  have probabilities  $P(a_1), P(a_2), \dots, P(a_K)$  and let us assume that  $P(a_1) \geq P(a_2) \geq P(a_3) \geq \dots \geq P(a_K)$ .

We now consider a simple example to illustrate the steps for Huffman coding.

**Steps to calculate Huffman Coding**

**Example** Let us consider a discrete memory less source with six letters having  $P(a_1)=0.3, P(a_2)=0.2, P(a_3)=0.15, P(a_4)=0.15, P(a_5)=0.12$  and  $P(a_6)=0.08$ .

- Arrange the letters in descending order of their probability (here they are arranged).
- Consider the last two probabilities. Tie up the last two probabilities. Assign, say, 0 to the last digit of representation for the least probable letter ( $a_6$ ) and 1 to the last digit of representation for the second least probable letter ( $a_5$ ). That is, assign ‘1’ to the upper arm of the tree and ‘0’ to the lower arm.

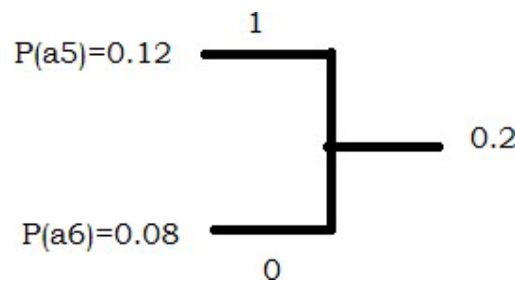

- (3) Now, add the two probabilities and imagine a new letter, say  $b_1$ , substituting for  $a_6$  and  $a_5$ . So  $P(b_1) = 0.2$ . Check whether  $a_4$  and  $b_1$  are the least likely letters. If not, reorder the letters as per Step#1 and add the probabilities of two least likely letters. For our example, it leads to:

$$P(a_1)=0.3, P(a_2)=0.2, P(b_1)=0.2, P(a_3)=0.15 \text{ and } P(a_4)=0.15$$

(4) Now go to Step#2 and start with the reduced ensemble consisting of  $a_1$ ,  $a_2$ ,  $a_3$ ,

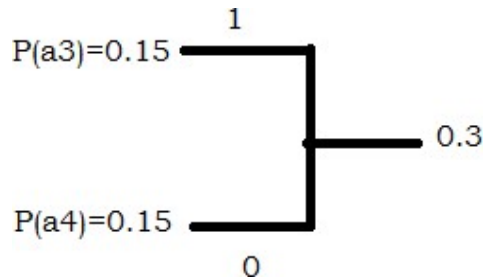

$a_4$  and  $b_1$ . Our example results in:

Here we imagine another letter  $b_1$ , with  $P(b_2)=0.3$ .

Continue till the first digits of the most reduced ensemble of two letters are assigned a '1' and a '0'.

Again go back to the step (2):  $P(a_1)=0.3$ ,  $P(b_2)=0.3$ ,  $P(a_2)=0.2$  and  $P(b_1)=0.2$ .

Now we consider the last two probabilities:

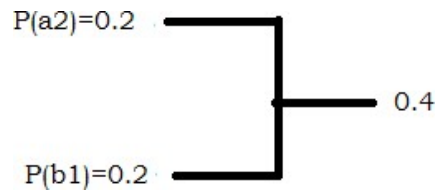

So,  $P(b_3)=0.4$ . Following Step#2 again, we get,  $P(b_3)=0.4$ ,  $P(a_1)=0.3$  and  $P(b_2)=0.3$ .

Next two probabilities lead to:

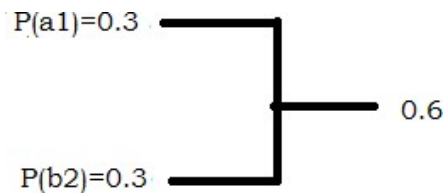

With  $P(b_4) = 0.6$ . Finally we get only two probabilities

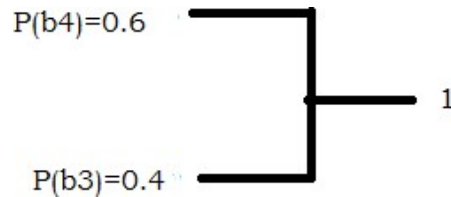

- Now, read the code tree inward, starting from the root, and construct the code words. The first digit of a codeword appears first while reading the code tree inward.

Hence, the final representation is:  $a_1=11$ ,  $a_2=01$ ,  $a_3=101$ ,  $a_4=100$ ,  $a_5=001$ ,  $a_6=000$ .

A few observations on the preceding example

- The event with maximum probability has least number of bits
- Prefix condition is satisfied. No representation of one letter is prefix for other. Prefix condition says that representation of any letter should not be a part of any other letter.
- Average length/letter (in bits) after coding is

$$= \sum P(a_i)n_i = 2.5 \text{ bits/letter.}$$

- Note that the entropy of the source is:  $H(X)=2.465$  bits/symbol. Average length per source letter after Huffman coding is a little bit more but close to the source entropy. In fact, the following celebrated theorem due to C. E. Shannon sets the limiting value of average length of code words from a DMS.

### Shannon–Hartley theorem

In information theory, the Shannon–Hartley theorem tells the maximum rate at which information can be transmitted over a communications channel of a specified bandwidth in the presence of noise. It is an application of the noisy-channel coding theorem to the archetypal case of a continuous-time analog communications channel subject to Gaussian noise. The theorem establishes Shannon's channel capacity for such a communication link, a

bound on the maximum amount of error-free information per time unit that can be transmitted with a specified bandwidth in the presence of the noise interference, assuming that the signal power is bounded, and that the Gaussian noise process is characterized by a known power or power spectral density.

The law is named after Claude Shannon and Ralph Hartley.

### **Hartley Shannon Law**

The theory behind designing and analyzing channel codes is called Shannon's noisy channel coding theorem. It puts an upper limit on the amount of information you can send in a noisy channel using a perfect channel code. This is given by the following equation:

$$C = B \times \log_2(1 + SNR)$$

where C is the upper bound on the capacity of the channel (bit/s), B is the bandwidth of the channel (Hz) and SNR is the Signal-to-Noise ratio (unit less).

### **Bandwidth-S/N Tradeoff**

The expression of the channel capacity of the Gaussian channel makes intuitive sense:

1. As the bandwidth of the channel increases, it is possible to make faster changes in the information signal, thereby increasing the information rate.
- 2 As S/N increases, one can increase the information rate while still preventing errors due to noise.
3. For no noise, S/N tends to infinity and an infinite information rate is possible irrespective of bandwidth.

Thus we may trade off bandwidth for SNR. For example, if  $S/N = 7$  and  $B = 4\text{kHz}$ , then the channel capacity is  $C = 12 \times 10^3$  bits/s. If the SNR increases to  $S/N = 15$  and B is decreased to 3kHz, the channel capacity remains the same. However, as B tends to 1, the channel capacity does not become infinite since, with an increase in bandwidth, the noise power also increases. If the noise power spectral density is  $\eta/2$ , then the total noise power is  $N = \eta B$ , so the Shannon-Hartley law becomes

$$\begin{aligned} C &= B \log_2 \left( 1 + \frac{S}{\eta B} \right) = \frac{S}{\eta} \left( \frac{\eta B}{S} \right) \log_2 \left( 1 + \frac{S}{\eta B} \right) \\ &= \frac{S}{\eta} \log_2 \left( 1 + \frac{S}{\eta B} \right)^{\eta B / S}. \end{aligned}$$

Noting that

$$\lim_{x \rightarrow 0} (1 + x)^{1/x} = e$$

and identifying  $x$  as  $x = S/\eta B$ , the channel capacity as  $B$  increases without bound becomes

$$C_\infty = \lim_{B \rightarrow \infty} C = \frac{S}{\eta} \log_2 e = 1.44 \frac{S}{\eta}.$$



## UNIT IV

### Linear Block Codes

#### Introduction

Coding theory is concerned with the transmission of data across noisy channels and the recovery of corrupted messages. It has found widespread applications in electrical engineering, digital communication, mathematics and computer science. The transmission of the data over the channel depends upon two parameters. They are transmitted power and channel bandwidth. The power spectral density of channel noise and these two parameters determine signal to noise power ratio.

The signal to noise power ratio determine the probability of error of the modulation scheme. Errors are introduced in the data when it passes through the channel. The channel noise interferes the signal. The signal power is reduced. For the given signal to noise ratio, the error probability can be reduced further by using coding techniques. The coding techniques also reduce signal to noise power ratio for fixed probability of error.

#### Principle of block coding

For the block of  $k$  message bits,  $(n-k)$  parity bits or check bits are added. Hence the total bits at the output of channel encoder are 'n'. Such codes are called  $(n,k)$  block codes. Figure illustrates this concept.

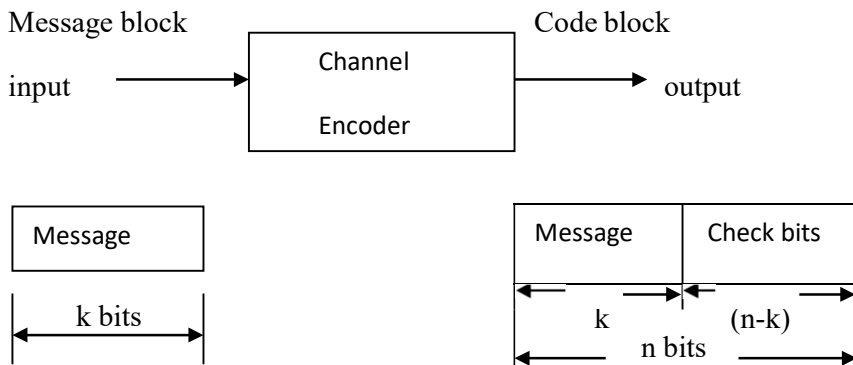

Figure: Functional block diagram of block coder

#### Types are

##### Systematic codes:

In the systematic block code, the message bits appear at the beginning of the code word. The message appears first and then check bits are transmitted in a block. This type of code is called systematic code.

##### Nonsystematic codes:

In the nonsystematic block code it is not possible to identify the message bits and check bits. They are mixed in the block.

Consider the binary codes and all the transmitted digits are binary.

### Linear Block Codes

A code is linear if the sum of any two code vectors produces another code vector. This shows that any code vector can be expressed as a linear combination of other code vectors. Consider that the particular code vector consists of  $m_1, m_2, m_3, \dots, m_k$  message bits and  $c_1, c_2, c_3, \dots, c_q$  check bits. Then this code vector can be written as,

$$X = (m_1, m_2, m_3, \dots, m_k, c_1, c_2, c_3, \dots, c_q)$$

Here  $q = n - k$

Where  $q$  are the number of redundant bits added by the encoder.

Code vector can also be written as

$$X = (M/C)$$

Where  $M = k$ -bit message vector

$C = q$ -bit check vector

The main aim of linear block code is to generate check bits and this check bits are mainly used for error detection and correction.

Example :

The (7, 4) linear code has the following matrix as a generator matrix

$$\mathbf{G} = \begin{bmatrix} \mathbf{g}_0 \\ \mathbf{g}_1 \\ \mathbf{g}_2 \\ \mathbf{g}_3 \end{bmatrix} = \begin{bmatrix} 1 & 1 & 0 & 1 & 0 & 0 & 0 \\ 0 & 1 & 1 & 0 & 1 & 0 & 0 \\ 1 & 1 & 1 & 0 & 0 & 1 & 0 \\ 1 & 0 & 1 & 0 & 0 & 0 & 1 \end{bmatrix}$$

If  $u = (1\ 1\ 0\ 1)$  is the message to be encoded, its corresponding code word would be

$$\begin{aligned} \mathbf{v} &= 1 \cdot \mathbf{g}_0 + 1 \cdot \mathbf{g}_1 + 0 \cdot \mathbf{g}_2 + 1 \cdot \mathbf{g}_3 \\ &= (1101000) + (0110100) + (1010001) \\ &= (0001101) \end{aligned}$$

A linear systematic (n, k) code is completely specified by a  $k \times n$  matrix  $G$  of the following form

$$\mathbf{G} = \begin{bmatrix} \mathbf{g}_0 \\ \mathbf{g}_1 \\ \mathbf{g}_2 \\ \vdots \\ \mathbf{g}_{k-1} \end{bmatrix} = \begin{array}{c} \longleftarrow \text{P matrix} \longrightarrow \\ \left[ \begin{array}{cccc|cccc} P_{00} & P_{01} & \cdot & \cdot & \cdot & P_{0,n-k-1} & 1 & 0 & 0 & \cdot & \cdot & \cdot & 0 \\ P_{10} & P_{11} & \cdot & \cdot & \cdot & P_{1,n-k-1} & 0 & 1 & 0 & \cdot & \cdot & \cdot & 0 \\ P_{20} & P_{21} & \cdot & \cdot & \cdot & P_{2,n-k-1} & 0 & 0 & 1 & \cdot & \cdot & \cdot & 0 \\ \vdots & \vdots & \vdots & \vdots & \vdots & \vdots & \vdots & \vdots & \vdots & \vdots & \vdots & \vdots & \vdots \\ P_{k-1,0} & P_{k-1,1} & \cdot & \cdot & \cdot & P_{k-1,n-k-1} & 0 & 0 & 0 & 0 & 0 & 0 & 1 \end{array} \right] \longrightarrow \text{k} \times \text{k identity matrix} \longleftarrow \end{array}$$

where  $p_{ii} = 0$  or  $1$

Let  $\mathbf{u} = (u_0, u_1, \dots, u_{k-1})$  be the message to be encoded. The corresponding code word is

$$\begin{aligned} \mathbf{v} &= (v_0, v_1, v_2, \dots, v_{n-1}) \\ &= (u_0, u_1, \dots, u_{k-1}) \cdot \mathbf{G} \end{aligned}$$

The components of  $\mathbf{v}$  are

$$v_{n-k+i} = u_i \quad \text{for } 0 \leq i < k$$

$$v_j = u_0 P_{0j} + u_1 P_{1j} + \dots + u_{k-1} P_{k-1,j} \quad \text{for } 0 \leq j < n-k$$

The  $n - k$  equations given by above equation are called parity-check equations of the code

### Example for Codeword

The matrix  $\mathbf{G}$  given by

$$\mathbf{G} = \begin{bmatrix} \mathbf{g}_0 \\ \mathbf{g}_1 \\ \mathbf{g}_2 \\ \mathbf{g}_3 \end{bmatrix} = \begin{bmatrix} 1 & 1 & 0 & 1 & 0 & 0 & 0 \\ 0 & 1 & 1 & 0 & 1 & 0 & 0 \\ 1 & 1 & 1 & 0 & 0 & 1 & 0 \\ 1 & 0 & 1 & 0 & 0 & 0 & 1 \end{bmatrix}$$

Let  $\mathbf{u} = (u_0, u_1, u_2, u_3)$  be the message to be encoded and  $\mathbf{v} = (v_0, v_1, v_2, v_3, v_4, v_5, v_6)$  be the corresponding code word

Solution :

$$\mathbf{v} = \mathbf{u} \cdot \mathbf{G} = (u_0, u_1, u_2, u_3) \cdot \begin{bmatrix} 1 & 1 & 0 & 1 & 0 & 0 & 0 \\ 0 & 1 & 1 & 0 & 1 & 0 & 0 \\ 1 & 1 & 1 & 0 & 0 & 1 & 0 \\ 1 & 0 & 1 & 0 & 0 & 0 & 1 \end{bmatrix}$$

By matrix multiplication, the digits of the code word  $\mathbf{v}$  can be determined.

$$v_6 = u_3$$

$$v_5 = u_2$$

$$v_4 = u_1$$

$$v_3 = u_0$$

$$v_2 = u_1 + u_2 + u_3$$

$$v_1 = u_0 + u_1 + u_2$$

$$v_0 = u_0 + u_2 + u_3$$

The code word corresponding to the message (1 0 1 1) is (1 0 0 1 0 1 1)

If the generator matrix of an  $(n, k)$  linear code is in systematic form, the parity-check matrix may take the following form

$$\mathbf{H} = \begin{bmatrix} \mathbf{I}_{n-k} & \mathbf{P}^T \end{bmatrix} = \begin{bmatrix} 1 & 0 & 0 & \cdot & \cdot & \cdot & 0 & P_{00} & P_{10} & \cdot & \cdot & \cdot & P_{k-1,0} \\ 0 & 1 & 0 & \cdot & \cdot & \cdot & 0 & P_{01} & P_{11} & \cdot & \cdot & \cdot & P_{k-1,1} \\ 0 & 0 & 1 & \cdot & \cdot & \cdot & 0 & P_{02} & P_{12} & \cdot & \cdot & \cdot & P_{k-1,2} \\ \cdot & & & & & & & & & & & & \\ \cdot & & & & & & & & & & & & \\ \cdot & & & & & & & & & & & & \\ 0 & 0 & 0 & \cdot & \cdot & \cdot & 1 & P_{0,n-k-1} & P_{1,n-k-1} & \cdot & \cdot & \cdot & P_{k-1,n-k-1} \end{bmatrix}$$

Encoding circuit for a linear systematic  $(n,k)$  code is shown below.

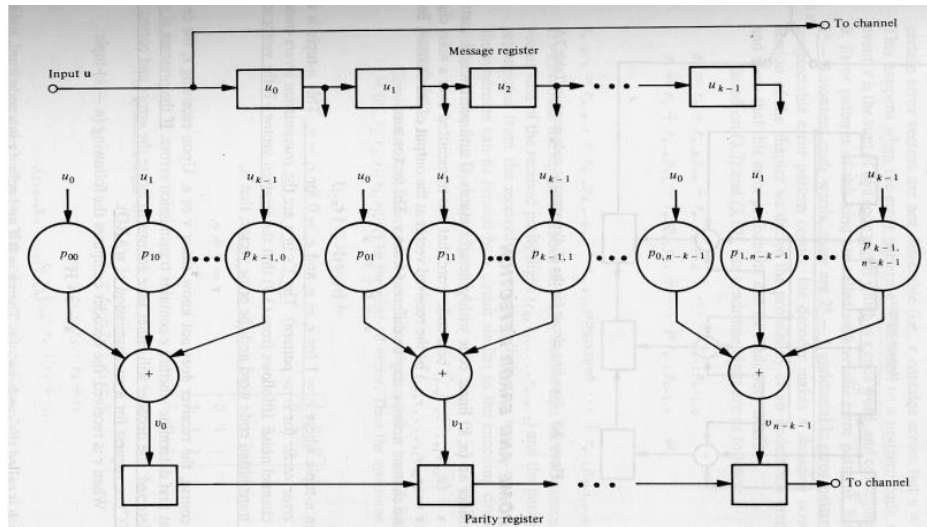

Figure: Encoding Circuit

For the block of  $k=4$  message bits,  $(n-k)$  parity bits or check bits are added. Hence the total bits at the output of channel encoder are  $n=7$ . The encoding circuit for  $(7, 4)$  systematic code is shown below.

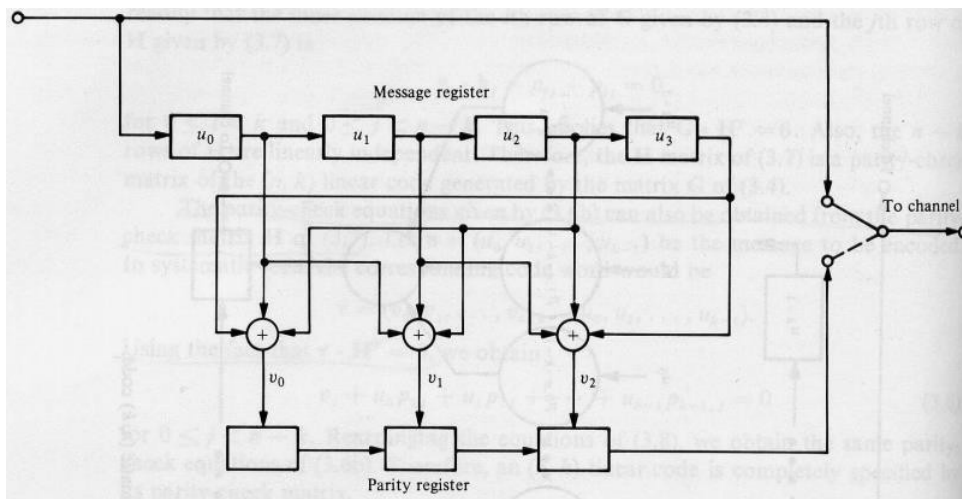
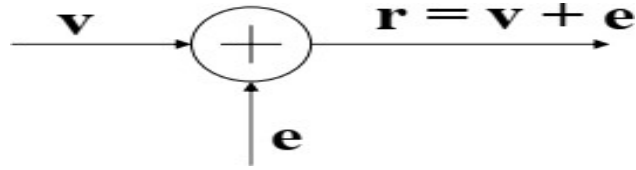

Figure: Encoding Circuit for  $(7,4)$  code

### Syndrome and Error Detection

Let  $v = (v_0, v_1, \dots, v_{n-1})$  be a code word that was transmitted over a noisy channel. Let  $r = (r_0, r_1, \dots, r_{n-1})$  be the received vector at the output of the channel



Where

$e = r + v = (e_0, e_1, \dots, e_{n-1})$  is an  $n$ -tuple and the  $n$ -tuple 'e' is called the error vector (or error pattern). The condition is

$$e_i = 1 \text{ for } r_i \neq v_i$$

$$e_i = 0 \text{ for } r_i = v_i$$

Upon receiving  $r$ , the decoder must first determine whether  $r$  contains transmission errors. If the presence of errors is detected, the decoder will take actions to locate the errors, correct errors (FEC) and request for a retransmission of  $v$ .

When  $r$  is received, the decoder computes the following  $(n - k)$ -tuple.

$$s = r \cdot HT$$

$$s = (s_0, s_1, \dots, s_{n-k-1})$$

where  $s$  is called the syndrome of  $r$ .

The syndrome is not a function of the transmitted codeword but a function of error pattern. So we can construct only a matrix of all possible error patterns with corresponding syndrome.

When  $s = 0$ , if and only if  $r$  is a code word and hence receiver accepts  $r$  as the transmitted code word. When  $s \neq 0$ , if and only if  $r$  is not a code word and hence the presence of errors has been detected. When the error pattern  $e$  is identical to a nonzero code word (i.e.,  $r$  contain errors but  $s = r \cdot HT = 0$ ), error patterns of this kind are called undetectable error patterns. Since there are  $2^k - 1$  non-zero code words, there are  $2^k - 1$  undetectable error patterns. The syndrome digits are as follows:

$$s_0 = r_0 + r_{n-k} p_{00} + r_{n-k+1} p_{10} + \dots + r_{n-1} p_{k-1,0}$$

$$s_1 = r_1 + r_{n-k} p_{01} + r_{n-k+1} p_{11} + \dots + r_{n-1} p_{k-1,1}$$

.

$$s_{n-k-1} = r_{n-k-1} + r_{n-k} p_{0,n-k-1} + r_{n-k+1} p_{1,n-k-1} + \dots + r_{n-1} p_{k-1,n-k-1}$$

The syndrome  $s$  is the vector sum of the received parity digits  $(r_0, r_1, \dots, r_{n-k-1})$  and the parity-check digits recomputed from the received information digits  $(r_{n-k}, r_{n-k+1}, \dots, r_{n-1})$ .

The below figure shows the syndrome circuit for a linear systematic  $(n, k)$  code.

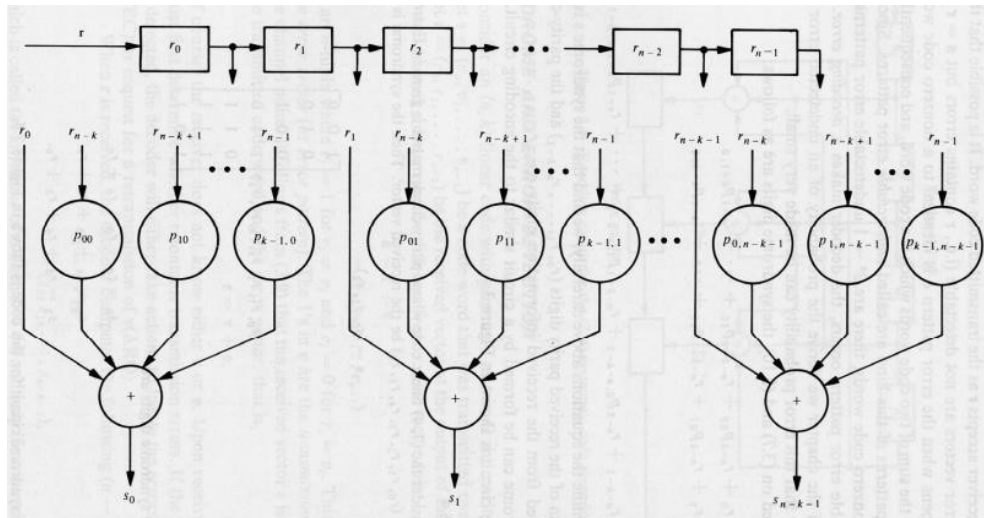

Figure: Syndrome Circuit

### Error detection and error correction capabilities of linear block codes:

If the minimum distance of a block code  $C$  is  $d_{\min}$ , any two distinct code vector of  $C$  differ in at least  $d_{\min}$  places. A block code with minimum distance  $d_{\min}$  is capable of detecting all the error pattern of  $d_{\min} - 1$  or fewer errors.

However, it cannot detect all the error pattern of  $d_{\min}$  errors because there exists at least one pair of code vectors that differ in  $d_{\min}$  places and there is an error pattern of  $d_{\min}$  errors that will carry one into the other. The random-error-detecting capability of a block code with minimum distance  $d_{\min}$  is  $d_{\min} - 1$ .

An  $(n, k)$  linear code is capable of detecting  $2^n - 2^k$  error patterns of length  $n$ . Among the  $2^n - 1$  possible non zero error patterns, there are  $2^k - 1$  error patterns that are identical to the  $2^k - 1$  non zero code words. If any of these  $2^k - 1$  error patterns occurs, it alters the transmitted code word  $v$  into another code word  $w$ , thus  $w$  will be received and its syndrome is zero.

If an error pattern is not identical to a nonzero code word, the received vector  $r$  will not be a code word and the syndrome will not be zero.

### Hamming Codes:

These codes and their variations have been widely used for error control in digital communication and data storage systems.

For any positive integer  $m \geq 3$ , there exists a Hamming code with the following parameters:

Code length:  $n = 2^m - 1$

Number of information symbols:  $k = 2^m - m - 1$

Number of parity-check symbols:  $n - k = m$

Error-correcting capability:  $t = 1$  ( $d_{\min} = 3$ )

The parity-check matrix  $H$  of this code consists of all the non zero  $m$ -tuple as its columns  $(2m-1)$

In systematic form, the columns of  $H$  are arranged in the following form

$$H = [I_m Q]$$

where  $I_m$  is an  $m \times m$  identity matrix

The sub matrix  $Q$  consists of  $2m - m - 1$  columns which are the  $m$ -tuples of weight 2 or more. The columns of  $Q$  may be arranged in any order without affecting the distance property and weight distribution of the code.

In systematic form, the generator matrix of the code is

$$G = [Q^T I_{2m-m-1}]$$

where  $Q^T$  is the transpose of  $Q$  and  $I_{2m-m-1}$  is an  $(2m - m - 1) \times (2m - m - 1)$  identity matrix.

Since the columns of  $H$  are nonzero and distinct, no two columns add to zero. Since  $H$  consists of all the nonzero  $m$ -tuples as its columns, the vector sum of any two columns, say  $h_i$  and  $h_j$ , must also be a column in  $H$ , say  $h_k$ ,  $h_i + h_j + h_k = 0$ . The minimum distance of a Hamming code is exactly 3.

Using  $H'$  as a parity-check matrix, a shortened Hamming code can be obtained with the following parameters :

Code length:  $n = 2m - 1 - 1$

Number of information symbols:  $k = 2m - m - 1 - 1$

Number of parity-check symbols:  $n - k = m$

Minimum distance :  $d_{\min} \geq 3$

When a single error occurs during the transmission of a code vector, the resultant syndrome is nonzero and it contains an odd number of 1's ( $e \times H'^T$  corresponds to a column in  $H'$ ). When double errors occurs, the syndrome is nonzero, but it contains even number of 1's.

Decoding can be accomplished in the following manner:

- i) If the syndrome  $s$  is zero, we assume that no error occurred
- ii) If  $s$  is nonzero and it contains odd number of 1's, assume that a single error occurred. The error pattern of a single error that corresponds to  $s$  is added to the received vector for error correction.
- iii) If  $s$  is nonzero and it contains even number of 1's, an uncorrectable error pattern has been detected.



**Problems:**

1.

The parity check bits of a (8,4) block code are generated by

$$c_0 = m_0 + m_1 + m_3$$

$$c_1 = m_0 + m_1 + m_2$$

$$c_2 = m_0 + m_2 + m_3$$

$$c_3 = m_1 + m_2 + m_3$$

where  $m_1, m_2, m_3$  and  $m_4$  are the message digits.

- (a) Find the generator matrix and the parity check matrix for this code.
- (b) Find the minimum weight of this code.
- (c) Find the error-detecting capabilities of this code.
- (d) Show through an example that this code can detect three errors/codeword.

**Solution**

$$\mathbf{1(a)} \quad \mathbf{c} = [c_0 \cdots c_3] = [b_0 \cdots b_3 m_0 \cdots m_3] = [m_0 \cdots m_3] \begin{bmatrix} 1 & 1 & 1 & 0 \\ 1 & 1 & 0 & 1 \\ 0 & 1 & 1 & 1 \\ 1 & 0 & 1 & 1 \end{bmatrix} \mathbf{I_4}$$

$$\text{Therefore, } \mathbf{G} = \begin{bmatrix} 1 & 1 & 1 & 0 \\ 1 & 1 & 0 & 1 \\ 0 & 1 & 1 & 1 \\ 1 & 0 & 1 & 1 \end{bmatrix} \mathbf{I_4}$$

$$\text{and then } \mathbf{H} = \begin{bmatrix} 1 & 1 & 0 & 1 \\ 1 & 1 & 1 & 0 \\ 1 & 0 & 1 & 1 \\ 0 & 1 & 1 & 1 \end{bmatrix}$$

(b)

<b>m</b>	<b>C</b>
0000	0000 0000
0001	1011 0001
0010	0111 0010
0011	1100 0011
0100	1101 0100
0101	0110 0101
0110	1010 0110
0111	0001 0111
1000	1110 1000
1001	0101 1001
1010	1001 1010
1011	0010 1011
1100	0011 1100
1101	1000 1101
1110	0100 1110
1111	1111 1111

Therefore, minimum weight = 4

(c)  $d_{\min} = \text{minimum weight} = 4$

Therefore, error-detecting capability =  $d_{\min} - 1 = 3$

(d) Suppose the transmitted code be 00000000 and the received code be 11100000.

$$\mathbf{s} = \mathbf{rH}^T = [11100000] \mathbf{I}_4 \begin{bmatrix} 1 & 1 & 0 & 1 \\ 1 & 1 & 1 & 0 \\ 1 & 0 & 1 & 1 \\ 0 & 1 & 1 & 1 \end{bmatrix}^T = [1110] \neq \mathbf{0}$$

**Binary Cyclic codes:**

Cyclic codes are the sub class of linear block codes.

Cyclic codes can be in systematic or non systematic form.

**Definition:**

A linear code is called a cyclic code if every cyclic shift of the code vector produces some other code vector.

**Properties of cyclic codes:**

- (i) Linearity
- (ii) Cyclic

**Linearity:** This property states that sum of any two code words is also a valid code word.

$$X_1 + X_2 = X_3$$

**Cyclic:** Every cyclic shift of valid code vector produces another valid code vector.

Consider an n-bit code vector

$$X = \{x_{n-1}, x_{n-2}, \dots, x_1, x_0\}$$

Here  $x_{n-1}, x_{n-2}, \dots, x_1, x_0$  represent individual bits of the code vector 'X'.

If the above code vector is cyclically shifted to left side i.e., One cyclic shift of X gives,

$$X' = \{x_{n-2}, \dots, x_1, x_0, x_{n-1}\}$$

Every bit is shifted to left by one position.

**Algebraic Structures of Cyclic Codes:**

The code words can be represented by a polynomial. For example consider the n-bit code word  $X = \{x_{n-1}, x_{n-2}, \dots, x_1, x_0\}$ .

This code word can be represented by a polynomial of degree less than or equal to (n-1) i.e.,

$$X(p) = x_{n-1}p^{n-1} + x_{n-2}p^{n-2} + \dots + x_1p + x_0$$

Here X(p) is the polynomial of degree (n-1)

p- Arbitrary variable of the polynomial

The power of p represents the positions of the codeword bits i.e.,

$p^{n-1}$  – MSB

$p^0$  -- LSB

p -- Second bit from LSB side

Polynomial representation due to the following reasons

- (i) These are algebraic codes, algebraic operations such as addition, multiplication, division, subtraction etc becomes very simple.
- (ii) Positions of the bits are represented with help of powers of p in a polynomial.

**Generation of code words in Non-systematic form:**

Let  $M = \{m_{k-1}, m_{k-2}, \dots, m_1, m_0\}$  be 'k' bits of message vector. Then it can be represented by the polynomial as,

$$M(p) = m_{k-1}p^{k-1} + m_{k-2}p^{k-2} + \dots + m_1p + m_0$$

Let X(p) be the code word polynomial

$$X(p) = M(p)G(p)$$

G(p) is the generating polynomial of degree 'q'

For (n,k) cyclic codes,  $q = n - k$  represent the number of parity bits.

The generating polynomial is given as

$$G(p) = p^q + g_{q-1}p^{q-1} + \dots + g_1p + 1$$

Where  $g_{q-1}, g_{q-2}, \dots, g_1$  are the parity bits.

If  $M_1, M_2, M_3, \dots$  etc are the other message vectors, then the corresponding code vectors can be calculated as

$$X_1(p) = M_1(p) G(p)$$

$$X_2(p) = M_2(p) G(p)$$

$$X_3(p) = M_3(p) G(p)$$

**Generation of Code vectors in systematic form:**

$$X = (\text{k message bits} : \text{(n-k) check bits}) = (m_{k-1}, m_{k-2}, \dots, m_1, m_0 : c_{q-1}, c_{q-2}, \dots, c_1, c_0)$$

$$C(p) = c_{q-1}p^{q-1} + c_{q-2}p^{q-2} + \dots + c_1p + c_0$$

The check bit polynomial is obtained by

$$C(p) = \text{rem} \left[ \frac{p^q M(p)}{G(p)} \right]$$

**Generator and Parity Check Matrices of cyclic codes:**

**Non systematic form of generator matrix:**

Since cyclic codes are sub class of linear block codes, generator and parity check matrices can also be defined for cyclic codes.

The generator matrix has the size of  $k \times n$ .

Let generator polynomial given by equation

$$G(p) = p^q + g_{q-1}p^{q-1} + \dots + g_1p + 1$$

Multiply both sides of this polynomial by  $p^i$  i.e.,

$$p^i G(p) = p^{i+q} + g_{q-1}p^{i+q-1} + \dots + g_1p^{i+1} + p^i \text{ and } i=(k-1), (k-2), \dots, 2, 1, 0$$

**Systematic form of generator matrix:**

Systematic form of generator matrix is given by

$$G = [I_k : P_{k \times q}]_{k \times n}$$

The  $t^{\text{th}}$  row of this matrix will be represented in the polynomial form as follows

$$t^{\text{th}} \text{ row of } G = p^{n-t} + R_t(p)$$

Where  $t = 1, 2, 3, \dots, k$

Lets divide  $p^{n-t}$  by a generator matrix  $G(p)$ . Then we express the result of this division in terms of quotient and remainder i.e.,

$$\frac{p^{n-t}}{G(p)} = \text{Quotient} + \frac{\text{Remainder}}{G(p)}$$

Here remainder will be a polynomial of degree less than  $q$ , since the degree of  $G(p)$  is ' $q$ '.

The degree of quotient will depend upon value of  $t$

Lets represent            Remainder =  $R_t(p)$

                                  Quotient =  $Q_t(p)$

$$\frac{p^{n-t}}{G(p)} = Q_t(p) + \frac{R_t(p)}{G(p)}$$

$$p^{n-t} = Q_t(p)G(p) + R_t(p)$$

And  $t = 1, 2, \dots, k$

$$p^{n-t} + R_t(p) = Q_t(p)G(p)$$

Represents  $t^{\text{th}}$  row of systematic generator matrix

**Parity check matrix**             $H = [P^T : I_q]_{q \times n}$

**Encoding using an (n-k) Bit Shift Register:**

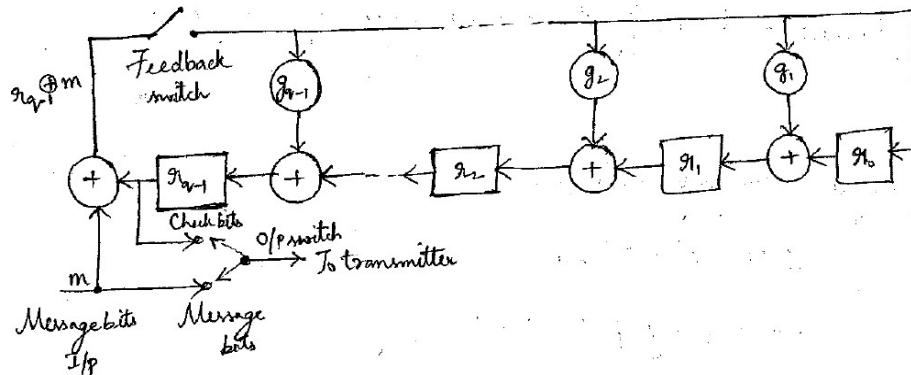

The feedback switch is first closed. The output switch is connected to message input. All the shift registers are initialized to zero state. The ' $k$ ' message bits are shifted to the transmitter as well as shifted to the registers.

After the shift of 'k' message bits the registers contain 'q' check bits. The feedback switch is now opened and output switch is connected to check bits position. With the every shift, the check bits are then shifted to the transmitter.

The block diagram performs the division operation and generates the remainder. Remainder is stored in the shift register after all message bits are shifted out.

**Syndrome Decoding, Error Detection and Error Correction:**

In cyclic codes also during transmission some errors may occur. Syndrome decoding can be used to correct those errors.

Lets represent the received code vector by Y.

If 'E' represents the error vector then the correct code vector can be obtained as

$$\mathbf{X}=\mathbf{Y}+\mathbf{E} \text{ or } \mathbf{Y}=\mathbf{X}+\mathbf{E}$$

In the polynomial form we can write above equation as

$$Y(p) = X(p)+E(p)$$

$$X(p) = M(p)G(p)$$

$$Y(p)= M(p)G(p) + E(p)$$

$$\frac{Y(p)}{G(p)} = \text{Quotient} + \frac{\text{Remainder}}{G(p)}$$

If  $Y(p)=X(p)$

$$\frac{X(p)}{G(p)} = \text{Quotient} + \frac{\text{Remainder}}{G(p)}$$

$$\frac{Y(p)}{G(p)} = Q(p) + \frac{R(p)}{G(p)}$$

$$Y(p)=Q(p)G(p) + R(p)$$

Clearly R(p) will be the polynomial of degree less than or equal to q-1

$$Y(p) =Q(p) G(p) +R(p)$$

$$M(p)G(p)+E(p)=Q(p)G(p)+R(p)$$

$$E(p)=M(p)G(p)+Q(p)G(p)+ R(p)$$

$$E(p)=[M(p)+Q(p)]G(p)+R(p)$$

This equation shows that for a fixed message vector and generator polynomial, an error pattern or error vector 'E' depends on remainder R.

For every remainder 'R' there will be specific error vector. Therefore we can call the remainder vector 'R' as syndrome vector 'S', or  $R(p)=S(p)$ . Therefore

$$\frac{Y(p)}{G(p)} = Q(p) + \frac{S(p)}{G(p)}$$

Thus Syndrome vector is obtained by dividing received vector Y (p) by G (p) i.e.,

$$S(p) = \text{rem}\left[\frac{Y(p)}{G(p)}\right]$$

### **Block Diagram of Syndrome Calculator:**

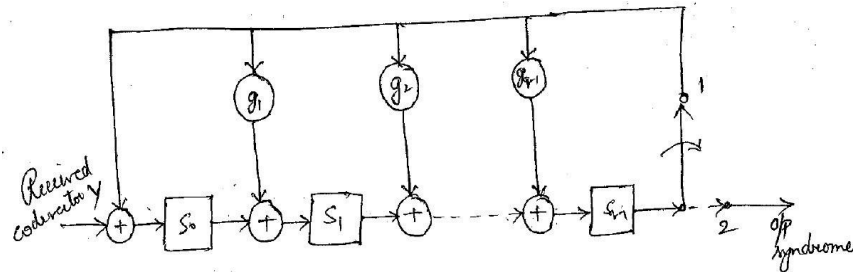

There are 'q' stage shift register to generate 'q' bit syndrome vector. Initially all the shift register contents are zero & the switch is closed in position 1.

The received vector Y is shifted bit by bit into the shift register. The contents of flip flops keep changing according to input bits of Y and values of  $g_1, g_2$  etc.

After all the bits of Y are shifted, the 'q' flip flops of shift register contain the q bit syndrome vector. The switch is then closed to position 2 & clocks are applied to shift register. The output is a syndrome vector  $S = (S_{q-1}, S_{q-2}, \dots, S_1, S_0)$

### **Decoder of Cyclic Codes:**

Once the syndrome is calculated, then an error pattern is detected for that particular syndrome. When the error vector is added to the received code vector Y, then it gives corrected code vector at the output.

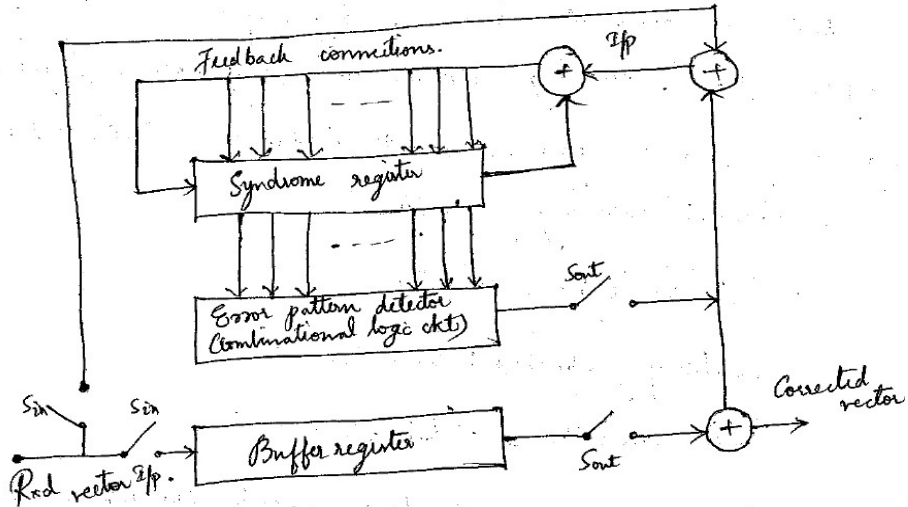

The switch named  $S_{out}$  is opened and  $S_{in}$  is closed. The bits of the received vector  $Y$  are shifted into the buffer register as well as they are shifted in to the syndrome calculator. When all the  $n$  bits of the received vector  $Y$  are shifted into the buffer register and Syndrome calculator the syndrome register holds a syndrome vector.

Syndrome vector is given to the error pattern detector. A particular syndrome detects a specific error pattern.

$S_{in}$  is opened and  $S_{out}$  is closed. Shifts are then applied to the flip flop of buffer registers, error register, and syndrome register.

The error pattern is then added bit by bit to the received vector. The output is the corrected error free vector.



# Unit-5

## Convolution codes

### Definition of Convolutional Coding

A convolutional coding is done by combining the fixed number of input bits. The input bits are stored in the fixed length shift register and they are combined with the help of mod-2 adders. This operation is equivalent to binary convolution and hence it is called *convolutional coding*. This concept is illustrated with the help of simple example given below.

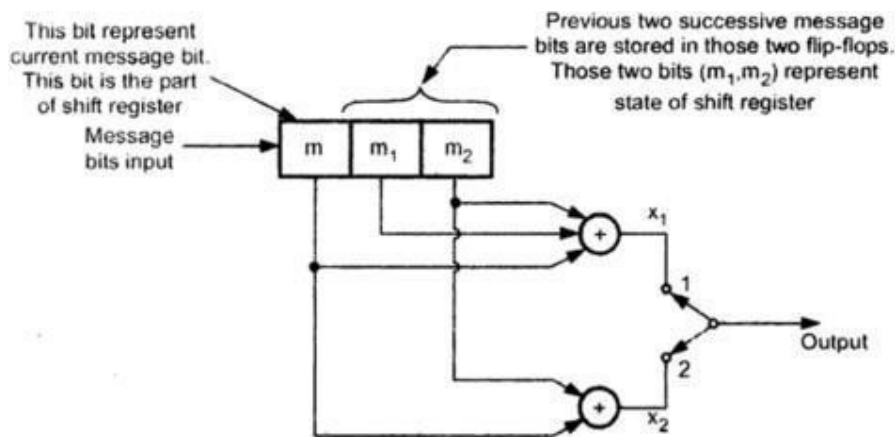

Fig. 4.4.1 Convolutional encoder with  $k = 3$ ,  $k = 1$  and  $n = 2$

### Operation :

Whenever the message bit is shifted to position ' $m$ ', the new values of  $x_1$  and  $x_2$  are generated depending upon  $m$ ,  $m_1$  and  $m_2$ .  $m_1$  and  $m_2$  store the previous two message bits. The current bit is present in  $m$ . Thus we can write,

$$x_1 = m \oplus m_1 \oplus m_2 \quad \dots (4.4.1)$$

and 
$$x_2 = m \oplus m_2 \quad \dots (4.4.2)$$

The output switch first samples  $x_1$  and then  $x_2$ . The shift register then shifts contents of  $m_1$  to  $m_2$  and contents of  $m$  to  $m_1$ . Next input bit is then taken and stored in  $m$ . Again  $x_1$  and  $x_2$  are generated according to this new combination of  $m$ ,  $m_1$  and  $m_2$  (equation 4.4.1 and equation 4.4.2). The output switch then samples  $x_1$  then  $x_2$ . Thus the output bit stream for successive input bits will be,

$$X = x_1x_2x_1x_2x_1x_2 \dots \text{ and so on} \quad \dots (4.4.3)$$

Here note that for every input message bit two encoded output bits  $x_1$  and  $x_2$  are transmitted. In other words, for a single message bit, the encoded code word is two bits i.e. for this convolutional encoder,

Number of message bits,  $k = 1$

Number of encoded output bits for one message bit,  $n = 2$

#### 4.4.1.1 Code Rate of Convolutional Encoder

The code rate of this encoder is,

$$r = \frac{k}{n} = \frac{1}{2} \quad \dots (4.4.4)$$

In the encoder of Fig. 4.4.1, observe that whenever a particular message bit enters a shift register, it remains in the shift register for three shifts i.e.,

First shift → Message bit is entered in position 'm'.

Second shift → Message bit is shifted in position  $m_1$ .

Third shift → Message bit is shifted in position  $m_2$ .

And at the fourth shift the message bit is discarded or simply lost by overwriting. We know that  $x_1$  and  $x_2$  are combinations of  $m$ ,  $m_1$ ,  $m_2$ . Since a single message bit remains in  $m$  during first shift, in  $m_1$  during second shift and in  $m_2$  during third shift; it influences output  $x_1$  and  $x_2$  for 'three' successive shifts.

#### 4.4.1.2 Constraint Length (K)

The constraint length of a convolution code is defined as the number of shifts over which a single message bit can influence the encoder output. It is expressed in terms of message bits.

For the encoder of Fig. 4.4.1 constraint length  $K = 3$  bits. This is because in this encoder, a single message bit influences encoder output for three successive shifts. At the fourth shift, the message bit is lost and it has no effect on the output.

#### 4.4.1.3 Dimension of the Code

The dimension of the code is given by  $n$  and  $k$ . We know that 'k' is the number of message bits taken at a time by the encoder. And 'n' is the encoded output bits for one message bits. Hence the dimension of the code is  $(n, k)$ . And such encoder is called  $(n, k)$  convolutional encoder. For example, the encoder of Fig. 4.4.1 has the dimension of  $(2, 1)$ .

#### 4.4.2 Time Domain Approach to Analysis of Convolutional Encoder

Let the sequence  $\{g_0^{(1)}, g_1^{(1)}, g_2^{(1)}, \dots, g_m^{(1)}\}$  denote the impulse response of the adder which generates  $x_1$  in Fig. 4.4.1. Similarly, Let the sequence  $\{g_0^{(2)}, g_1^{(2)}, g_2^{(2)}, \dots, g_m^{(2)}\}$  denote the impulse response of the adder which generates  $x_2$  in Fig. 4.4.1. These impulse responses are also called *generator sequences* of the code.

Let the incoming message sequence be  $\{m_0, m_1, m_2, \dots\}$ . The encoder generates the two output sequences  $x_1$  and  $x_2$ . These are obtained by convolving the generator sequences with the message sequence. Hence the name convolutional code is given. The sequence  $x_1$  is given as,

$$x_1 = x_i^{(1)} = \sum_{l=0}^M g_l^{(1)} m_{i-l} \quad i = 0, 1, 2, \dots \quad \dots (4.4.6)$$

Here  $m_{i-l} = 0$  for all  $l > i$ . Similarly the sequence  $x_2$  is given as,

$$x_2 = x_i^{(2)} = \sum_{l=0}^M g_l^{(2)} m_{i-l} \quad i = 0, 1, 2, \dots \quad \dots (4.4.7)$$

**Note :** All additions in above equations are as per mod-2 addition rules.

As shown in the Fig. 4.4.1, the two sequences  $x_1$  and  $x_2$  are multiplexed by the switch. Hence the output sequence is given as,

$$\{x_i\} = \{x_0^{(1)} x_0^{(2)} x_1^{(1)} x_1^{(2)} x_2^{(1)} x_2^{(2)} x_3^{(1)} x_3^{(2)} \dots\} \quad \dots (4.4.8)$$

$$v_1 = x_i^{(1)} = \{x_0^{(1)} x_1^{(1)} x_2^{(1)} x_3^{(1)} \dots\}$$

$$v_2 = x_i^{(2)} = \{x_0^{(2)} x_1^{(2)} x_2^{(2)} x_3^{(2)} \dots\}$$

Observe that bits from above two sequences are multiplexed in equation (4.4.8). The sequence  $\{x_i\}$  is the output of the convolutional encoder.

## Transform Domain Approach to Analysis of Convolutional Encoder

In the previous section we observed that the convolution of generating sequence and message sequence takes place. These calculations can be simplified by applying the transformations to the sequences. Let the impulse responses be represented by polynomials. i.e.,

$$g^{(1)}(p) = g_0^{(1)} + g_1^{(1)}p + g_2^{(1)}p^2 + \dots + g_M^{(1)}p^M \quad \dots (4.4.13)$$

$$g^{(2)}(p) = g_0^{(2)} + g_1^{(2)}p + g_2^{(2)}p^2 + \dots + g_M^{(2)}p^M \quad \dots (4.4.14)$$

Thus the polynomials can be written for other generating sequences. The variable 'p' is unit delay operator in above equations. It represents the time delay of the bits in impulse response.

Similarly we can write the polynomial for message polynomial i.e.,

$$m(p) = m_0 + m_1p + m_2p^2 + \dots + m_{L-1}p^{L-1} \quad \dots (4.4.15)$$

Here L is the length of the message sequence. The convolution sums are converted to polynomial multiplications in the transform domain. i.e.,

$\begin{aligned} x^{(1)}(p) &= g^{(1)}(p) \cdot m(p) \\ x^{(2)}(p) &= g^{(2)}(p) \cdot m(p) \end{aligned}$	... (4.4.16)
--	--------------

The above equations are the output polynomials of sequences  $x_i^{(1)}$  and  $x_i^{(2)}$ .

## Code Tree, Trellis and State Diagram for a Convolution Encoder

Now let's study the operation of the convolutional encoder with the help of code tree, trellis and state diagram. Consider again the convolutional encoder of Fig. 4.4.1. It is reproduced below for convenience.

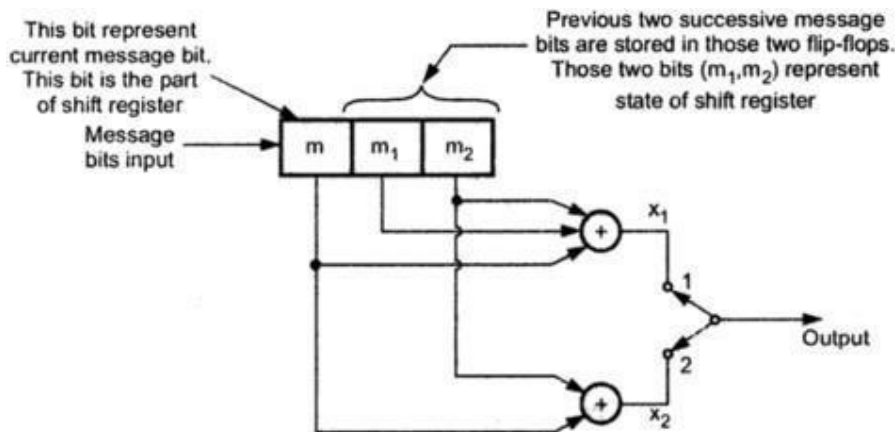

Fig. 4.4.4 Convolutional encoder with  $k = 1$  and  $n = 2$

#### States of the Encoder

In Fig. 4.4.4 the previous two successive message bits  $m_1$  and  $m_2$  represents state. The input message bit  $m$  affects the 'state' of the encoder as well as outputs  $x_1$  and  $x_2$  during that state. Whenever new message bit is shifted to ' $m$ ', the contents of  $m_1$  and  $m_2$  define new state. And outputs  $x_1$  and  $x_2$  are also changed according to new state  $m_1, m_2$ , and message bit  $m$ . Let's define these states as shown in Table 4.4.1.

Let the initial values of bits stored in  $m_1$  and  $m_2$  be zero. That is  $m_1 m_2 = 00$  initially and the encoder is in state 'a'.

$m_2$	$m_1$	State of encoder
0	0	a
0	1	b
1	0	c
1	1	d

Table 4.4.1 States of the encoder of Fig. 4.4.4

#### Development of the Code Tree

Let us consider the development of code tree for the message sequence  $m = 110$ . Assume that  $m_1 m_2 = 00$  initially.

1) When  $m = 1$  i.e. first bit

The first message input is  $m = 1$ . With this input  $x_1$  and  $x_2$  will be calculated as

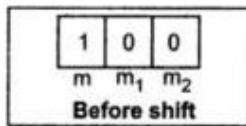

$$x_1 = 1 \oplus 0 \oplus 0 = 1$$

$$x_2 = 1 \oplus 0 = 1$$

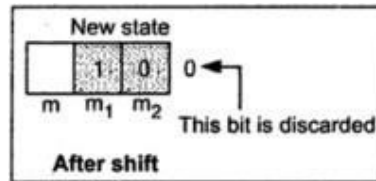

The values of  $x_1x_2 = 11$  are transmitted to the output and register contents are shifted to right by one bit position as shown.

Thus the new state of encoder is  $m_2m_1 = 01$  or 'b' and output transmitted are  $x_1x_2 = 11$ . This shows that if encoder is in state 'a' and if input is  $m = 1$  then the next state is 'b' and outputs are  $x_1x_2 = 11$ . The first row of Table 4.4.2 illustrates this operation.

The last column of this table shows the code tree diagram. The code tree diagram starts at node or state 'a'. The diagram is reproduced as shown in Fig. 4.4.5.

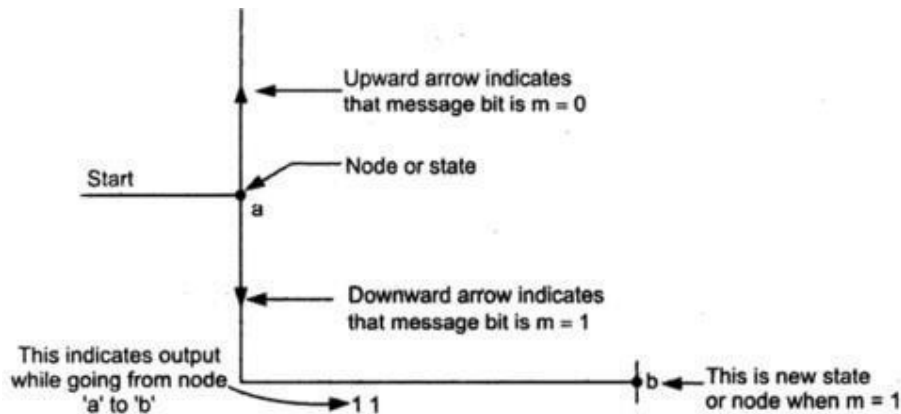
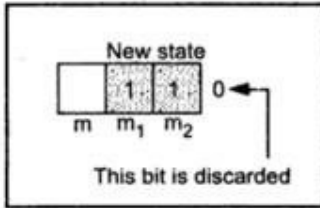
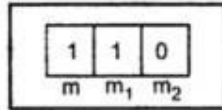

**Fig. 4.4.5 Code tree from node 'a' to 'b'**

Observe that if  $m = 1$  we go downward from node 'a'. Otherwise if  $m = 0$ , we go upward from node 'a'. It can be verified that if  $m = 0$  then next node (state) is 'a' only. Since  $m = 1$  here we go downwards toward node b and output is 11 in this node (or state).

2) When  $m = 1$  i.e. second bit

Now let the second message bit be 1. The contents of shift register with this input will be as shown below.



$$x_1 = 1 \oplus 1 \oplus 0 = 0$$

$$x_2 = 1 \oplus 0 = 1$$

These values of  $x_1x_2 = 01$  are then transmitted to output and register contents are shifted to right by one bit. The next state formed is as shown.

Thus the new state of the encoder is  $m_2m_1 = 11$  or 'd' and the outputs transmitted are  $x_1x_2 = 01$ . Thus the encoder goes from state 'b' to state 'd'

if input is '1' and transmitted output  $x_1x_2 = 01$ . This operation is illustrated by Table 4.4.2 in second row. The last column of the table shows the code tree for those first and second input bits.

**Example 4.4.8 :** Determine the state diagram for the convolutional encoder shown in Fig. 4.4.32. Draw the trellis diagram through the first set of steady state transitions. On the second trellis diagram, show the termination of trellis to all zero state.

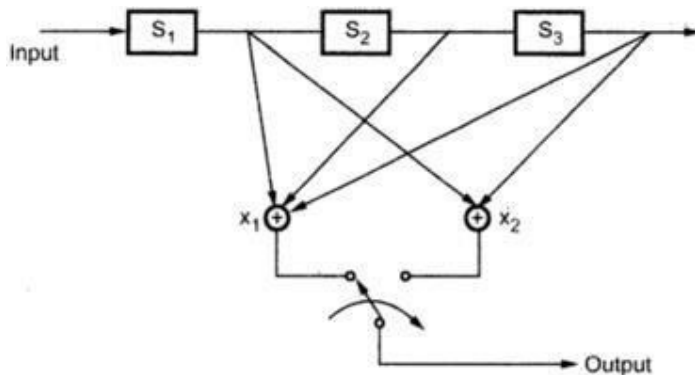

Fig. 4.4.32 Convolutional encoder of example 4.4.8

Sol. : (i) To determine dimension of the code :

For every message bit ( $k=1$ ), two output bits ( $n=2$ ) are generated. Hence this is rate  $\frac{1}{2}$  code. Since there are three stages in the shift register, every message bit will affect output for three successive shifts. Hence constraint length,  $K=3$ . Thus,

$$k = 1, \quad n = 2 \text{ and } K = 3$$

ii) To obtain the state diagram :

First, let us define the states of the encoder.

$$s_3 s_2 = 00, \quad \text{state 'a'}$$

$$s_3 s_2 = 01, \quad \text{state 'b'}$$

$$s_3 s_2 = 10, \quad \text{state 'c'}$$

$$s_3 s_2 = 11, \quad \text{state 'd'}$$

A table is prepared that lists state transitions, message input and outputs. The table is as follows :

Sr. No.	Current state $s_3 s_2$	Input $s_1$	Outputs $x_1 = s_1 \oplus s_2 \oplus s_3$ $x_2 = s_1 \oplus s_3$		Next state $s_2 s_1$
1	a = 0 0	0	0	0	0 0, i.e. a
		1	1	1	0 1, i.e. b
2	b = 0 1	0	1	0	1 0, i.e. c
		1	0	1	1 1, i.e. d

3	c = 1 0	0	1	1	0 0, i.e. a
		1	0	0	0 1, i.e. b
4	d = 1 1	0	0	1	1 0, i.e. c
		1	1	0	1 1, i.e. d

**Table 4.4.8 : State transition table**

Based on above table, the state diagram can be prepared easily. It is shown below in Fig. 4.4.33.

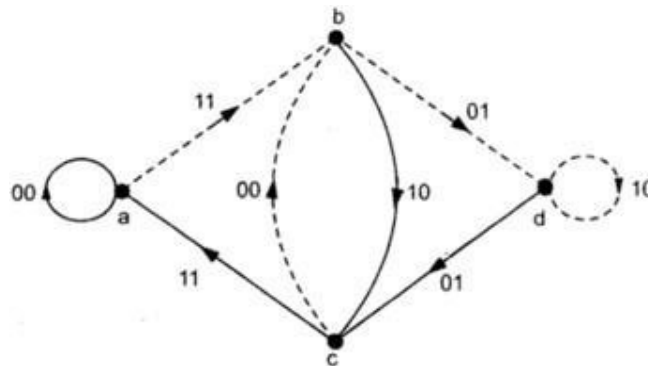

**iii) To obtain trellis diagram for steady state :**

From Table 4.4.9, the code trellis diagram can be prepared. It is steady state diagram. It is shown below.



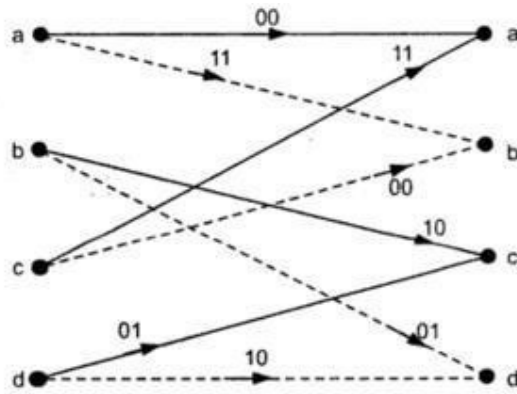

Fig. 4.4.34 Code trellis diagram for steady state

Decoding methods of Convolution code:

1. Viterbi decoding
2. Sequential decoding
3. Feedback decoding

Viterbi algorithm for decoding of convolution codes (maximum likelihood decoding):

Let represent the received signal by  $y$ .

Convolutional encoding operates continuously on input data

Hence there are no code vectors and blocks such as.

**Metric:** it is the discrepancy between the received signal  $y$  and the decoding signal at particular node. This metric can be added over few nodes a particular path

**Surviving path:** this is the path of the decoded signal with minimum metric

In Viterbi decoding a metric is assigned to each surviving path

Metric of the particular is obtained by adding individual metric on the nodes along that path.

$Y$  is decoded as the surviving path with smallest metric.

Example:

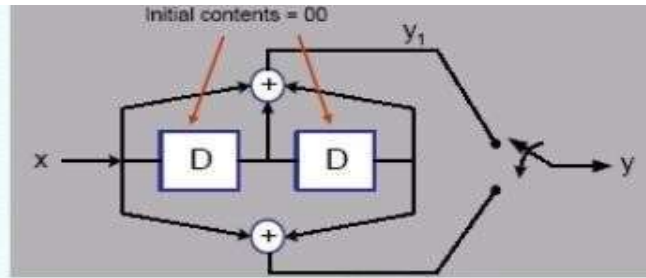

Transition

Exe:

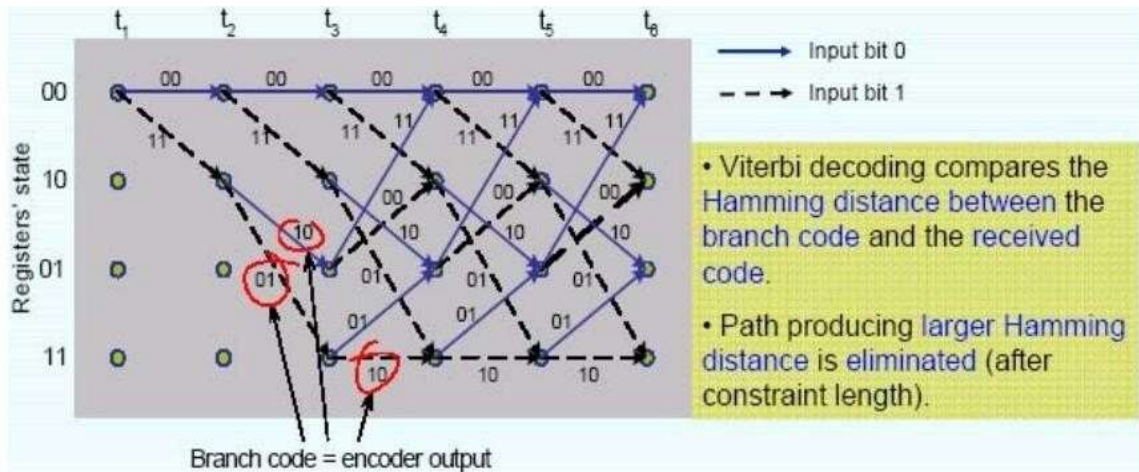

Input data :  $m = 1\ 1\ 0\ 1\ 1$   
 Codeword :  $X = 11\ 01\ 01\ 00\ 01$   
 Received code :  $Z = 11\ 01\ 01\ 10\ 01$

