

**ANTENNA
AND
WAVE PROPAGATION**

UNIT-I RADIATION: Radiation Mechanism, Potential functions-heuristic approach, Maxwell's equation approach, Potential functions for sinusoidal oscillations, alternating current element, Power radiated by current element, Application to short antennas, assumed current distribution, Radiation from quarter wave Monopole / half wave dipole, Traveling wave antennas and the effect of the point of feed on standing wave antennas

UNIT-II Antenna Fundamentals: Isotropic, Directional, Omni-directional patterns, principal pattern, near-andfar-field regions, Radiation density, Radiation intensity, reciprocity, directivity and power gain, effective aperture, Half power Beam width, polarization, input impedance, efficiency, Friss transmission equation.

UNIT-III Array Antennas: Two element array, Uniform linear array, Side lobe level and beam width of broadside array, Beam width of end fire array, Principle of multiplication of patterns, Effect of earth on vertical patterns, Binomial array, Basic principle of Dolph-Tschebyscheff array.

UNIT-IV Characteristics of Typical Antennas: V and Rhombic antennas, Folded Dipole, Loop antenna, Yagi- Uda array, Helical antenna, Log periodic antenna, Pyramidal and conical Horn antenna, Corner reflector antenna, Parabolic reflector antennas - Paraboloid and parabolic cylinder, Cassegrain system of reflectors, Basic principles of slot antennas, Basic characteristics of micro strip antennas, feeding methods, methods of analysis, design of rectangular and circular patch antennas.

UNIT-V Radio Wave Propagation: Ground wave Propagation, Earth constants, Space-wave Propagation, Effect of curvature of an Ideal Earth, Variations of Field strength with height in space-wave Propagation, Atmospheric effects in space-wave Propagation, Radio-Horizon, Duct Propagation, Extended-range Propagation resulting from Tropospheric Scattering, ionospheric Propagation, Gyro frequency, Refraction and reflection of Sky Waves by the Ionosphere, Critical Frequency, Skip Distance, Maximum Usable Frequency.

TEXT BOOKS:

- 1) Edward C Jordan and Keith G Balmain, Electromagnetic Waves and Radiating Systems, 2nd Edition, PHI, 2003
- 2) Constantine A Balanis, Antenna Theory: Analysis and Design, Harper and Row Publishers, 2002
- 3) G.S.N.Raju, Antennas and Wave Propagation, 1st Edition, Pearson Publication, Singapore.
- 4) J.D. Kraus, Antennas, McGraw Hill, 1988.

REFERENCE BOOKS:

- 1) R.E. Collin, Antennas and Radio Wave Propagation, McGraw Hill, 1985.
- 2) R.C. Johnson and H. Jasik, Antenna Engineering Handbook, McGraw ill, 1984.
- 3) J. Bahl and P. Bhartia, Micro Strip Antennas, Artech House, 1980.
- 4) R.K. Shevgaonkar, Electromagnetic Waves, Tata McGraw Hill, 2005
- 5) F.E. Terman, Electronic and Radio Engineering, Mc Graw Hill, 1985

UNIT – I: ANTENNA BASICS

HISTORY OF AN ANTENNAS:

The first radio antennas were built by Heinrich Hertz, a professor at the Technical Institute in Karlsruhe, Germany. Heinrich Hertz's end-loaded half-wave dipole transmitting antenna and resonant half-wave receiving loop operating at $\lambda = 8$ m in 1886.

Hertz was the pioneer and father of radio, his invention remained a laboratory curiosity until 20-year-old Guglielmo Marconi of Bologna, Italy, went on to add tuning circuits, big antenna and ground systems for longer wavelengths, and was able to signal over large distances. In mid-December 1901 he startled the world by receiving signals at St. Johns, Newfoundland, from a transmitting station he had constructed at Poldhu in Cornwall, England.

Guglielmo Marconi's square conical antenna at Poldhu, England, in 1905 for sending transatlantic signals at wavelengths of 1000s of meters. Shown in fig. below. Rarely has an invention captured the public imagination as Marconi's wireless did at the beginning of the 20th century. With the advent of radar during World War II, centimeter wavelengths became popular and the entire radio spectrum opened up to wide usage.

Thousands of communication satellites bristling with antennas now circle the earth in low, medium, and geostationary orbits. The geostationary satellites form a ring around the earth similar to the rings around Saturn. Your hand-held Global Position Satellite (GPS) receiver gives your latitude, longitude and elevation to centimeter accuracy anywhere on or above the earth day or night, cloudy or clear.

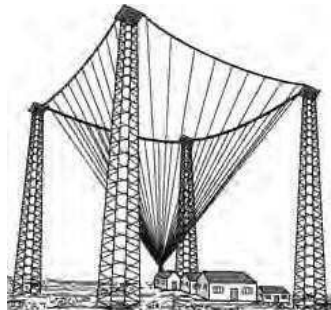

Very Large Array (VLA) of 27 steerable parabolic dish antennas each 25 m in diameter operating at centimeter wavelengths for observing radio sources at distances of billions of light-years. The array is located at the National Radio Astronomy Observatory near Socorro,

New Mexico in **1980**. Shown in fig. below. Our probes with their arrays of antennas have visited the planets of the solar system and beyond, responding to our commands and sending back photographs and data at centimeter wavelengths even though it may take over 5 hours for the signals to travel one way. And our radio telescope antennas operating at millimeter to kilometer wavelengths receive signals from objects so distant that it has taken more than 10 billion years for the signals to arrive.



Helix antenna array on one of 24 Global Position Satellites (GPS) in Medium Earth Orbit (MEO) at 20,000km. Operating at $\lambda = 20$ cm, these satellites provide you on or above the earth with your position (latitude, longitude and elevation) to an accuracy of better than 1 meter in **1985**. Shown in fig. below.

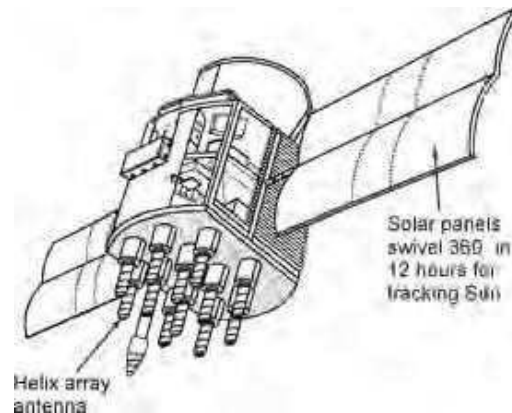

In the above image, the antennas help the communication to be established in the whole area, including the valleys and mountains. This process would obviously be easier than laying a wiring system throughout the area.



The ubiquitous, hand-held cellphone with half-wave antenna operating at $\lambda = 30$ cm, which connects you to everybody. Antennas are the essential communication link for aircraft and ships. Antennas for cellular phones and all types of wireless devices link us to everyone and every thing. With mankind's activities expanding into space, the need for antennas will grow to an unprecedented degree. Antennas will provide the vital links to and from everything out there. The future of antennas reaches to the stars.



INTRODUCTION:

Antennas are our electronic eyes and ears on the world. They are our links with space. They are an essential, integral part of our civilization.

An antenna (or aerial) is an electrical device which converts electric power into radio waves, and vice versa. It is usually used with a radio transmitter or radio receiver. In transmission, a radio transmitter supplies an oscillating radio frequency electric current to the antenna's terminals, and the antenna radiates the energy from the current as electromagnetic waves (radio waves).

In reception, an antenna intercepts some of the power of an electromagnetic wave in order to produce a tiny voltage at its terminals, that is applied to a receiver to be amplified. Antennas are essential components of all equipment that uses radio. They are used in systems such as radio broadcasting, broadcast television, two-way radio, communications receivers, radar, cell phones and satellite communications, as well as other devices such as garage door openers, wireless microphones, blue tooth enabled devices, wireless computer networks, baby monitors, and RFID tags on merchandise.

Typically an antenna consists of an arrangement of metallic conductors ("elements"), electrically connected (often through a transmission line) to the receiver or transmitter. Antennas act as transformers between conducted waves and electromagnetic waves propagating freely in space. Their name is borrowed from zoology, in which the Latin word *antennae* is used to describe the long, thin feelers possessed by many insects.

In wireless communication systems, signals are radiated in space as an electromagnetic wave by using a receiving, transmitting antenna and a fraction of this radiated power is intercepted by using a receiving antenna. An antenna is a device used for radiating or receiving radio waves. An antenna can also be thought of as a transitional structure between free space and a guiding device (such as transmission line or waveguide).

Usually antennas are metallic structures, but dielectric antennas are also used now a days, a rigid metallic structure is called an "antenna" while the wire form is called an "aerial" With this introduction, in this first lecture let us see some common types of antennas that are in use:

What is meant by Dimension? A *dimension* defines some physical characteristic.

Types of Dimensions:

1. Fundamental dimensions: The dimensions of length, mass, time, electric current, temperature, and luminous intensity are considered as the *fundamental dimensions*. For

example Let the letters L, M, T, I, T , and I represent the dimensions of length, mass, time, electric current, temperature, and luminous intensity.

2. Secondary dimensions: A secondary dimension which can be expressed in terms of the fundamental dimension of length squared (l^2).

What is a Unit? A *unit* is a standard or reference by which a dimension can be expressed numerically. The meter is a unit in terms of which the dimension of length can be expressed, and the kilogram is a unit in terms of which the dimension of mass can be expressed.

Types of units:-

1. **Fundamental units**:- The units for the fundamental dimensions are called the *fundamental* or *base units*. The International System of Units, abbreviated SI, is used, in this system the *meter, kilogram, second, ampere, kelvin, and candela* are the base units for the six fundamental dimensions of length, mass, time, electric current, temperature, and luminous intensity.

2. **Secondary units**:- The units for other dimensions are called *secondary* or *derived* units and are based on these fundamental unit.

TYPES OF ANTENNAS:

Wired antennas: (fig 1,2 and 3)

- Dipole, monopole, loop antenna, helix antennas:- Usually used in personal applications, automobiles, buildings, ships, aircrafts and spacecrafts.

Fig1



Fig 2

Fig 3

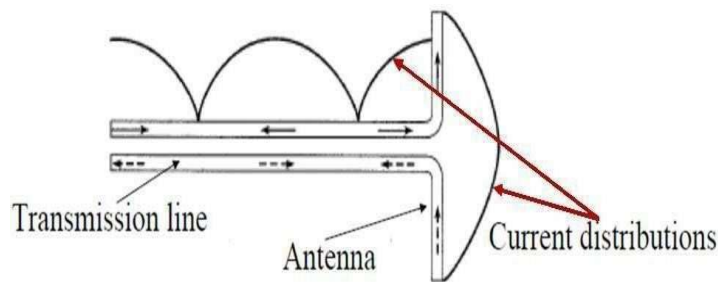

Conditions for radiation

Aperture antennas: (fig 4 and 5)

- Horn antennas, waveguide opening :- Usually used in aircrafts and space crafts, because these antennas can be flush.



Fig4



Fig 5

Reflector antennas: (fig 6)

- Parabolic reflectors, corner reflectors :- These are high gain antennas usually used in radio astronomy, microwave communication and satellite tracking.



Fig 6

Lens antennas:

- Convex-plane, convex-convex, convex-concave and concave-plane lenses o
These antennas are usually used for very high frequency applications.

Microstrip antennas: (fig 7)

- rectangular, circular etc. shaped metallic patch above a ground plane :- Used in aircraft, spacecraft, satellites, missiles, cars, mobile phones etc.

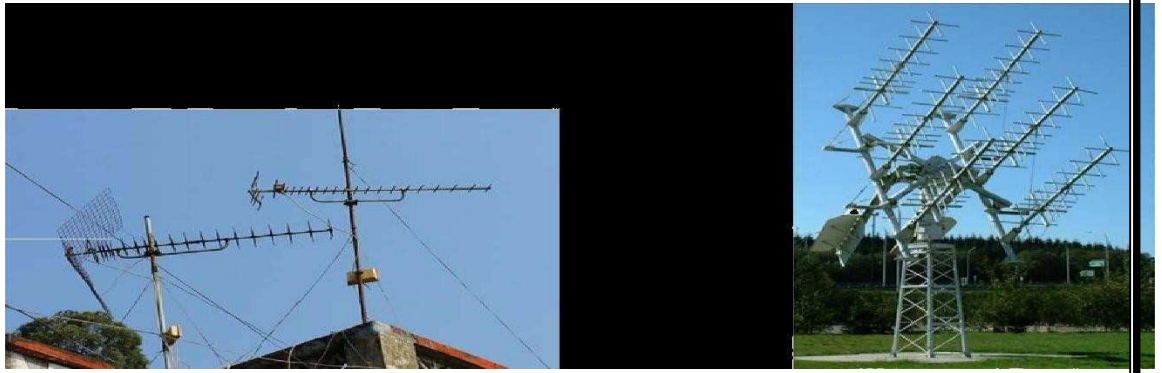

Fig 7

Array antennas: Yagi-Uda antenna, microstrip patch array, aperture array, slotted waveguide array :- Used for very high gain applications with added advantage, such as controllable radiation pattern.

Radiation Mechanism: When electric charges undergo acceleration or deceleration, electromagnetic radiation will be produced. Hence it is the motion of charges, that is current is the source of radiation. Here it may be highlighted that, not all current distributions will produce a strong enough radiation for communication.

Antennas radiate or couple or concentrates or directs electromagnetic energy in the desired or assigned direction. An antenna may be isotropic or non directional (omni-directional) and un isotropic or directional.

There is no proper rule for selecting an antenna for any particular frequency range or application. While choosing an antenna many electrical, mechanical and structural accepts are to be taken into account.

There accepts include radiation pattern, gain, efficiency, impedance, frequency characteristics, shape size, weight and look at antenna and above all these makes their economic viability. The cost, size and shape makes the main difference on usage of different frequencies.

High gain and Directivity are the basic requirements for the transmitting antennas. Where as low side lobes and large signal to noise ratio are key selection criteria for receiving antennas. Antenna may vary in size from the order of few millimetres(strip antenna) to thousands of feet (dish antennas for astronomical observations)

To give a mathematical flavour to it, as we know

$$A = \frac{\mu I dl}{4\pi r}$$

$$dl \frac{dl}{dt} = dlq \frac{dv}{dt} = dlqa$$

$$E = -\nabla V - \frac{\partial A}{\partial t} = -\nabla V - \frac{\mu dl}{4\pi r} \frac{\partial I}{\partial t} = -\nabla V - \frac{\mu dl}{4\pi r} qa$$

- As shown in these equations, to create radiation (electric field), there must be a time-varying current dI/dt or an acceleration (or deceleration) a of a charge q .
- If the charge is not moving, a current is not created and there is no radiation.
- If a charge is moving with an uniform velocity, there is no radiation if the wire is straight, and infinite in extent there is radiation if the wire is curved, bent, discontinuous, terminated or truncated , If the charge is oscillating in a time-motion, it radiates even if the wire is straight

So, it is the current distribution on the antennas that produce the radiation. Usually these current distributions are excited by transmission lines and waveguides as shown in the fig. 8.

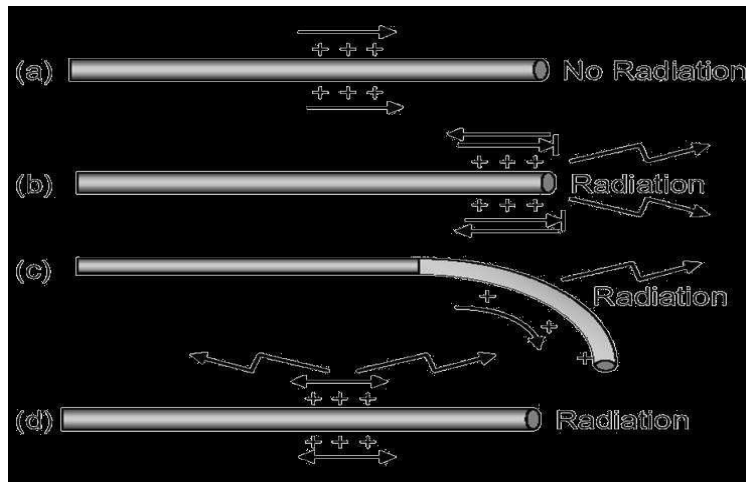

Fig 8. Antenna radiation mechanism

BASIC PRINCIPLE OF RADIATION:-

Under time varying conditions , Max wells equations predict the radiation of EM energy from current source(or accelerated charge). This happens at all frequencies , but is insignificant as long as the size of the source region is not comparable to the wavelength. While transmission lines are designed to minimize this radiation loss, radiation into free space becomes main purpose in case of Antennas.

For steady state harmonic variation, usually we focus on time changing current For transients or pulses ,we focus on accelerated charge The radiation is perpendicular to the acceleration. The radiated power is proportional to the square of .

$$I L \text{ or } Q V$$

Where

I = Time changing current in Amps/sec

L = Length of the current element in meters

Q = Charge in Coulombs

V = Time changing velocity

Transmission line opened out in a Tapered fashion as an Antenna:

- a) **As Transmitting Antenna:**— Here the Transmission Line is connected to source or generator at one end. Along the uniform part of the line energy is guided as Plane TEM wave with little loss. Spacing between line is a small fraction of λ . As the line is opened out and the separation between the two lines becomes comparable to λ , it acts like an antenna and launches a free space wave since currents on the transmission Line flow out on the antenna but fields associated with them keep on going. From the circuit point of view the antenna appears to be a resistance R_r , called Radiation resistance.
- b) **As Receiving Antenna** —Active radiation by other Antenna or Passive radiation from distant objects raises the apparent temperature of R_r . This has nothing to do with the physical temperature of the antenna itself but is related to the temperature of distant objects that the antenna is looking at. R_r may be thought of as virtual resistance that does not exist physically but is a quantity coupling the antenna to distant regions of space via a virtual transmission line.

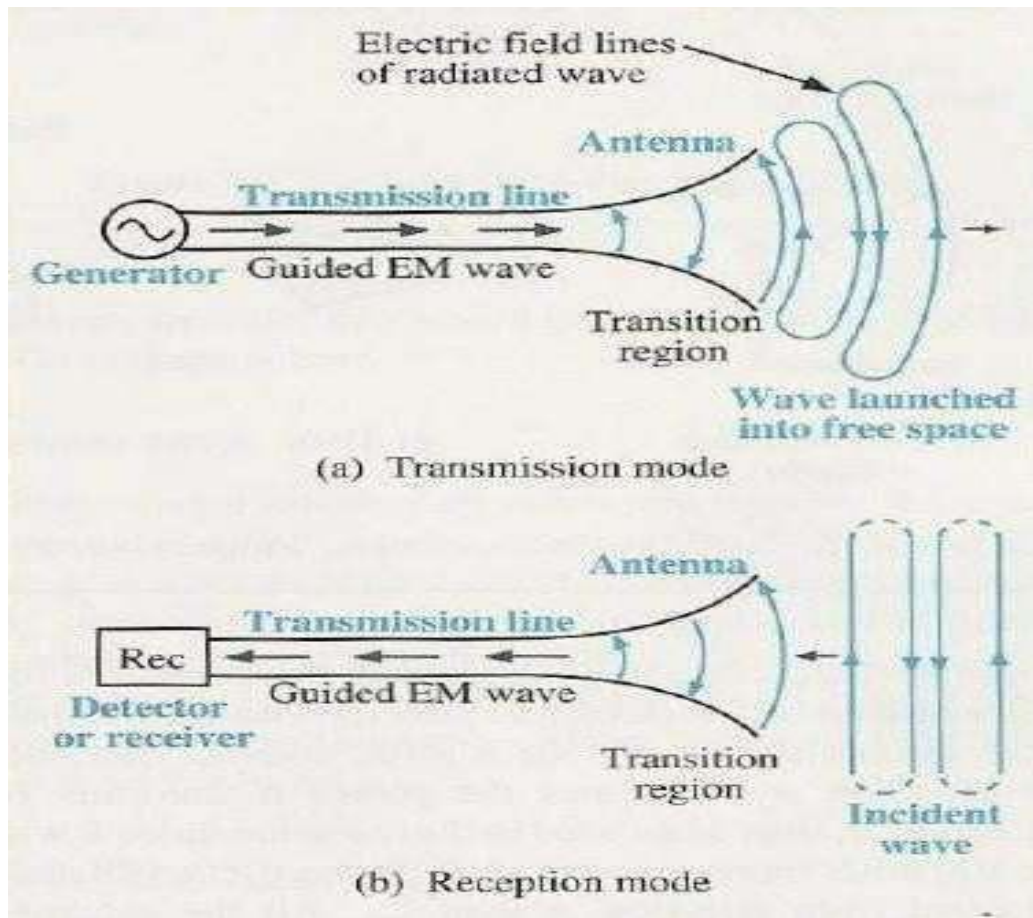

Fig. 9:Antenna as a a) Transmission Mode b) Receiving Mode

Reciprocity-An antenna exhibits identical impedance during Transmission or Reception, same directional patterns during Transmission or Reception, same effective height while transmitting or receiving . Transmission and reception antennas can be used interchangeably. Medium must be linear, passive and isotropic(physical properties are the same in different directions.) Antennas are usually optimised for reception or transmission, not both.

CURRENT AND VOLTAGE DISTRIBUTION:-

a) A current flowing in a wire of a length related to the RF produces an electromagnetic field. This field radiates from the wire and is set free in space. The principles of radiation of electromagnetic energy are based on two laws.

- (1) A moving electric field creates a magnetic (H) field.
- (2) A moving magnetic field creates an electric (E) field.

b) In space, these two fields will be in-phase and perpendicular to each other at any given moment. Although a conductor is usually considered to be present when a moving electric or magnetic field is mentioned, the laws governing these fields do not say anything about a conductor. Thus, these laws hold true whether a conductor is present or not

c) The current and voltage distribution on a half-wave Hertz antenna is shown in Figure 10. In view A, a piece of wire is cut in half and attached to the terminals of a high frequency (HF), alternating current (AC) generator. The frequency of the generator is set so each half of the wire is one-quarter wavelength of the output. The symbol for wavelength is the Greek letter lambda (λ). The result is the common dipole antenna.

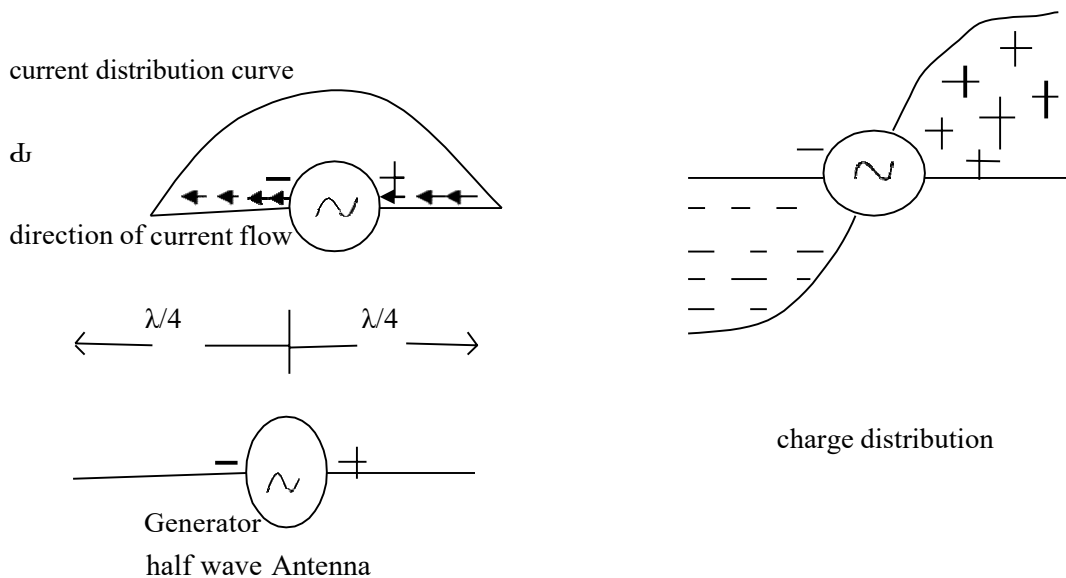

Fig: 10

1. A current flows in the antenna with an amplitude that varies with the generator voltage.
2. A sine wave distribution of charge exists on the antenna. The charges can reverse polarity for every half cycle.
3. The sine wave variation in charge magnitude lags the sine wave variation in current by one-quarter cycle.

Antenna Parameters:

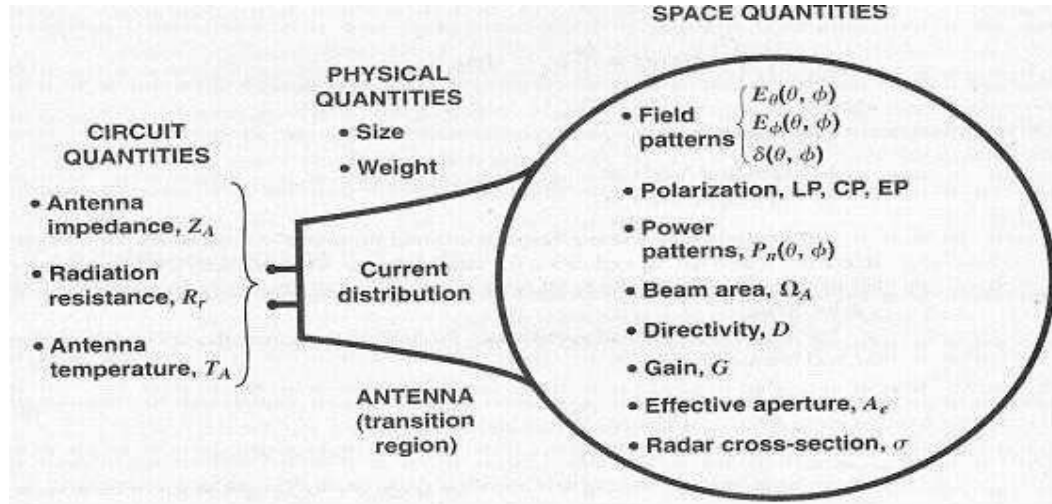

Figure 11: Schematic diagram of basic parameters

- d) At a given moment, the generator's right side is positive and its left side is negative. A law of physics states that like charges repel each other. Consequently, electrons will flow away from the negative terminal as far as possible while the positive terminal will attract electrons. View B of Figure 1-1 shows the direction and distribution of electron flow. The distribution curve shows that most current flows in the center and none flows at the ends. The current distribution over the antenna is always the same, regardless of how much or how little current is flowing. However, current at any given point on the antenna will vary directly with the amount of voltage that the generator develops.
- e) One-quarter cycle after the electrons begin to flow, the generator develops its minimum voltage and the current decreases to zero. At that moment, the condition shown in view C of Figure 1-1 will exist. Although no current is flowing, a minimum number of electrons are at the left end of the line and a minimum number are at the right end. The charge distribution along the wire varies as the voltage of the generator varies (view C).

DUAL CHARACTERISTICS OF AN ANTENNA:

The duality of an antenna specifies a circuit device on one hand and a space device on the other hand. Figure.11 shows the schematic diagram of basic antenna parameters, illustrating dual characteristics of an antenna.

Most practical transmitting antennas are divided into two basic classifications, HERTZ ANTENNAS (half-wave) and MARCONI (quarter-wave) ANTENNAS.

Hertz antennas are generally installed some distance above the ground and are positioned to radiate either vertically or horizontally. Marconi antennas operate with one end grounded and are mounted perpendicular to the earth or a surface acting as a ground. The Hertz antenna, also referred to as a dipole, is the basis for some of the more complex antenna systems used today. Hertz antennas are generally used for operating frequencies of 2 MHz and above, while Marconi antennas are used for operating frequencies below 2 MHz. All antennas regardless of their shape or size, have four basic characteristics: reciprocity, directivity, gain, and polarization.

Isotropic Radiator: An antenna does not radiate uniformly in all directions. For the sake of a reference, we consider a hypothetical antenna called an isotropic radiator having equal radiation in all directions.

Directional Antenna: A directional antenna is one which can radiate or receive electromagnetic waves more effectively in some directions than in others.

Radiation Pattern:

The relative distribution of radiated power as a function of direction in space (i.e., as function of θ and ϕ) is called the radiation pattern of the antenna. Instead of 3D surface, it is common practice to show planar cross section radiation pattern. E-plane and H-plane patterns give two most important views. The E-plane pattern is a view obtained from a section containing maximum value of the radiated field and electric field lies in the plane of the section. Similarly when such a section is taken such that the plane of the section contains H field and the direction of maximum radiation. A typical radiation pattern plot is shown in figure 12.

The main lobe contains the direction of maximum radiation. However in some antennas, more than one major lobe may exist. Lobe other than major lobe are called minor lobes. Minor lobes can be further represent radiation in the considered direction and require to be minimized.

HPBW or half power beam width: Refers to the angular width between the points at which the radiated power per unit area is one half of the maximum.

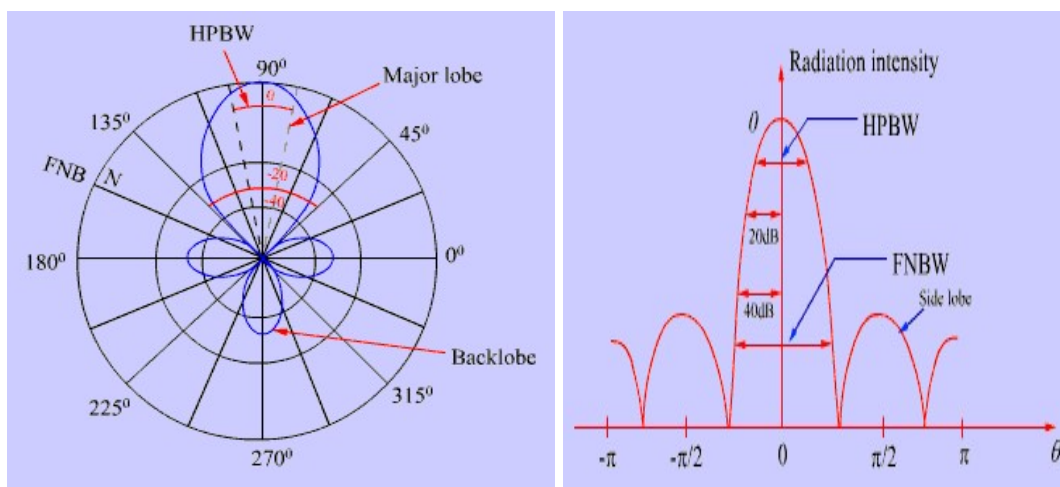

Figure 12: Radiation Pattern

Similarly FNBW (First null beam width) refers to the angular width between the first two nulls as shown in Figure 12. By the term beam width we usually refer to 3 dB beam width or HPBW.

RECIPROcity (In terms of picture representation): Is the ability to use the same antenna for both transmitting and receiving. The electrical characteristics of an antenna apply equally, regardless of whether you use the antenna for transmitting or receiving. The more efficient an antenna is for transmitting a certain frequency, the more efficient it will be as a receiving antenna for the same frequency. This is illustrated by figure 13(view A). When the antenna is used for transmitting, maximum radiation occurs at right angles to its axis. When the same antenna is used for receiving (view B), its best reception is along the same path; that is, at right angles to the axis of the antenna.

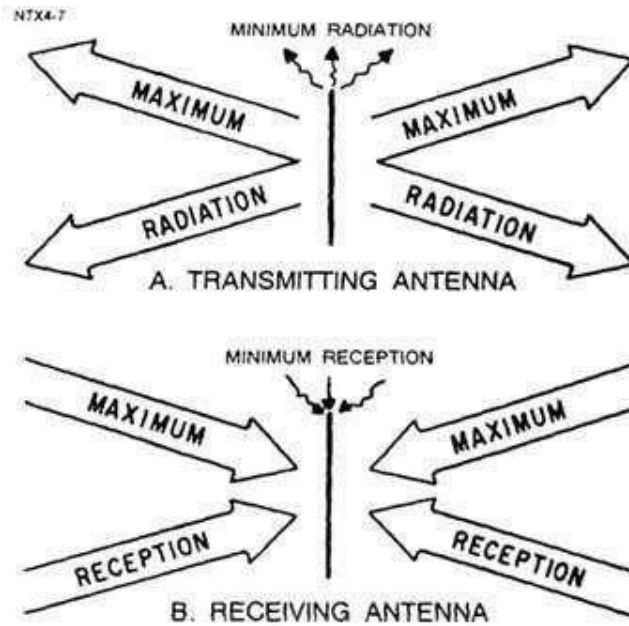

Figure. 13 Reciprocity of Antenna.

POLARIZATION:- Polarization of an electromagnetic wave refers to the orientation of the electric field component of the wave. For a linearly polarized wave, the orientation stays the same as the wave moves through space. If we choose our axis system such that the electric field is vertical, we say that the wave is vertically polarized. If our transmitting antenna is vertically oriented, the electromagnetic wave radiated is vertically polarized since, as we saw before, the electric field is in the direction of the current in the antenna.

The convention is to refer to polarization with reference to the surface of the earth. Precise orientation is less problematic than one might think, since waves bounce off the ground and other objects so do not maintain their original orientation anyway. In space, horizontal and vertical lose their meaning, so alignment of linearly polarized sending and receiving antennas is more difficult to achieve. These difficulties are somewhat circumvented by circular polarization of waves. With circular polarization, the tip of the electric field vector traces out a circle when viewed in the direction of propagation.

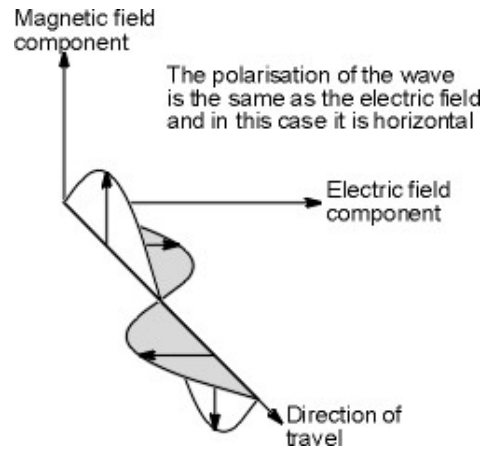
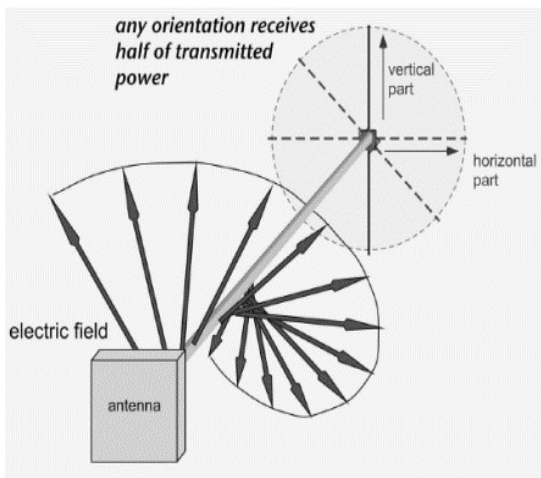

Figure 14. Polarisation

POLARIZATION CATEGORIES:-

Vertical and horizontal are the simplest forms of polarization and they both fall into a category known as linear polarization. However it is also possible to use circular polarization. This has a number of benefits for areas such as satellite applications where it helps overcome the effects of propagation anomalies, ground reflections and the effects of the spin that occur on many satellites.

Circular polarization is a little more difficult to visualize than linear polarization. However it can be imagined by visualizing a signal propagating from an antenna that is rotating. The tip of the electric field vector will then be seen to trace out a helix or corkscrew as it travels away from the antenna. Circular polarization can be seen to be either right or left handed dependent upon the direction of rotation as seen from the transmitter.

Another form of polarization is known as elliptical polarization. It occurs when there is a mix of linear and circular polarization. This can be visualized as before by the tip of the electric field vector tracing out an elliptically shaped corkscrew.

However it is possible for linearly polarized antennas to receive circularly polarized signals and vice versa. The strength will be equal whether the linearly polarized antenna is mounted vertically, horizontally or in any other plane but directed towards the arriving signal. There will be some degradation because the signal level will be 3 dB less than if a circularly polarized antenna of the same sense was used. The same situation exists when a circularly polarized antenna receives a linearly polarized signal.

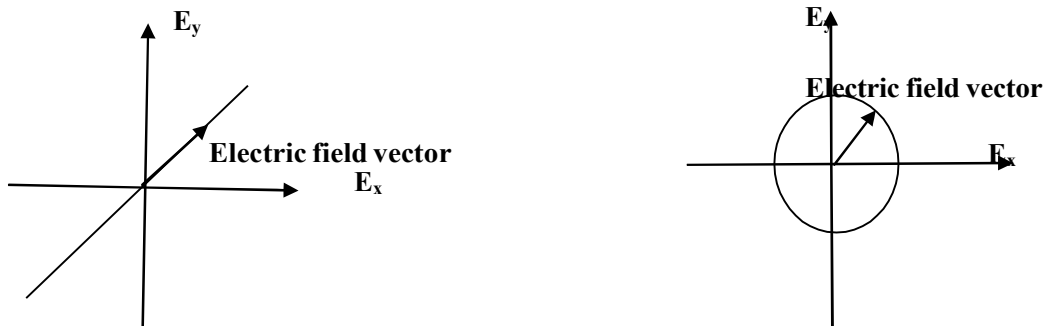

Fig 15 (a) Linear Polarization (b) Circular Polarization

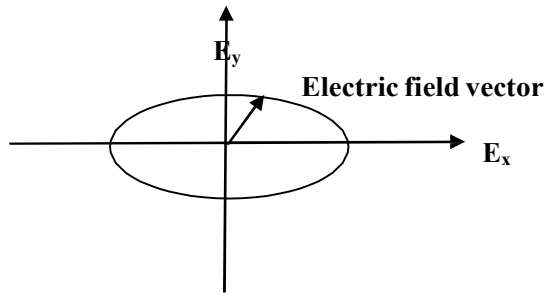

Fig 15 (c) Elliptical Polarization

RADIATION PATTERN:-

Practically any antenna cannot radiate energy with same strength uniformly in all directions- radiation will be large in one direction , while zero or minimum in other directions.

The radiation from the antenna in any direction is measured in terms of field strength at a point located at a particular distance from an antenna.

The field strength can be calculated by measuring voltage at two points on an electric links of face and their dividing by distance between two points. Hence unit of radiation pattern is V/m. The radiation pattern of an antenna is the important characteristic of antenna because it indicates the distribution of energy radiated by an antenna in the space.

The radiation pattern is nothing but a graph which shows the variation of actual field strength of EM field at all the points equidistant from the antenna. Hence, it is 3-D graph.

Radiation patterns are of two types:

- (i) If the radiation of the antenna is represented graphically as a function of direction it is called **radiation pattern**. But if the radiation of the antenna is expressed in terms of the field strength E (V/m) , then the graphical representation is called **field strength pattern or field radiation pattern**.

BASED ON MODE OF DIRECTION OF PATTERN, TYPES OF PATTERNS ARE:-

(1) DIRECTIONAL PATTERNS AND OMNIDIRECTIONAL PATTERNS:-

A radiator acting as a lossless, hypothetical antenna radiating equally in all directions is called **isotropic radiator**.

An antenna with a property of radiating or receiving the EM waves more effectively in same direction than in other directions is called **directional antenna**.

The radiation pattern of such antenna is called directional pattern when antenna has max. directivity greater than that of a half wave dipole is know as directional antenna.

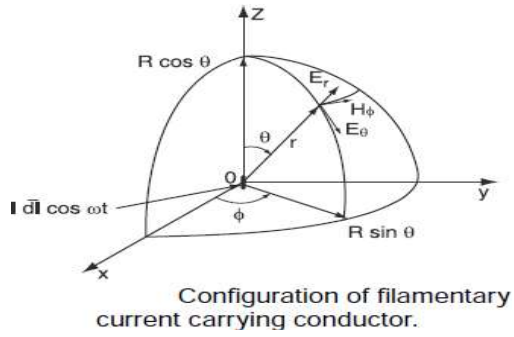

(2) FIELD RADIATION PATTERN:-

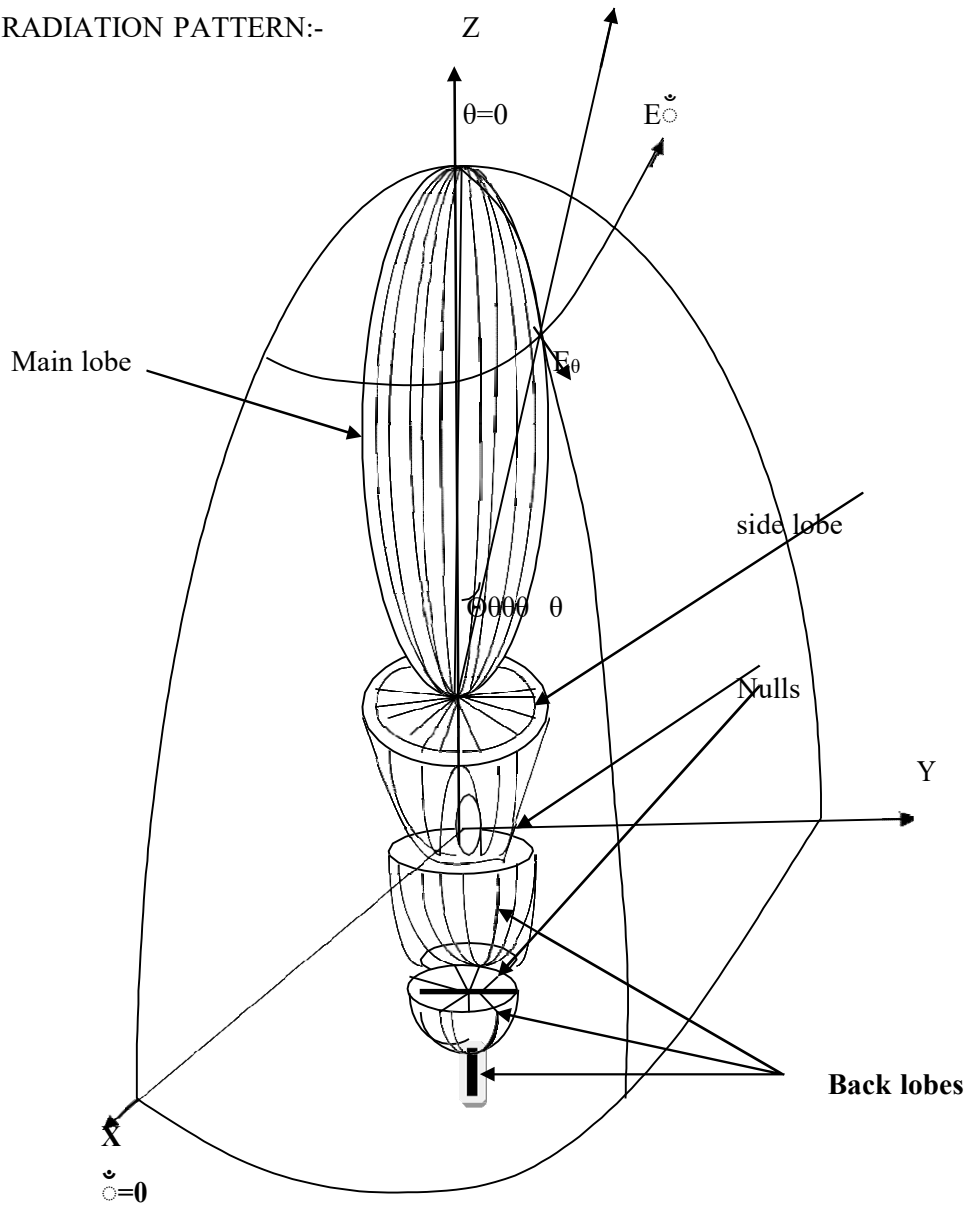

Fig. 3-D radiation pattern with main lobe, side lobes and back lobes.

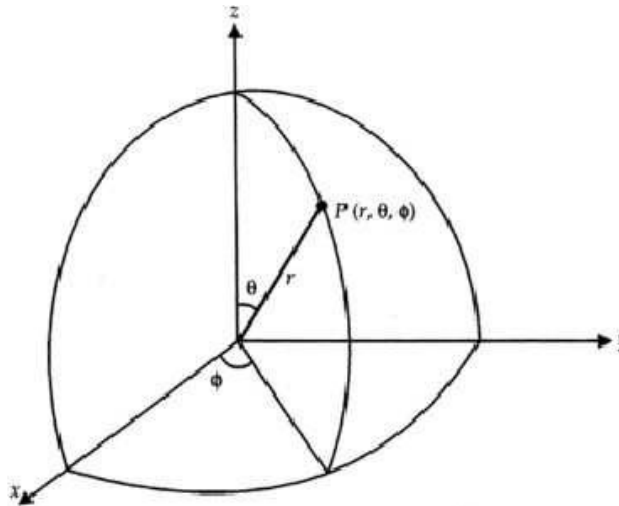

Figure 1.3 A point in spherical coordinate system

$$\theta = \cos^{-1} \frac{z}{\sqrt{x^2 + y^2 + z^2}} \quad 0 \leq \theta \leq \pi$$

$$\phi = \tan^{-1} \frac{y}{x} \quad 0 \leq \phi \leq 2\pi$$

The relations between the variables of cylindrical and spherical coordinates are given by

$$\begin{aligned} \mathbf{A} &= (A_r, A_\theta, A_\phi) \\ &= [(A_x \sin \theta \cos \phi + A_y \sin \theta \sin \phi + A_z \cos \theta), \\ &\quad (A_x \cos \theta \cos \phi + A_y \cos \theta \sin \phi - A_z \sin \theta), \\ &\quad (-A_x \sin \phi + A_y \cos \phi)] \end{aligned}$$

The dot products of \mathbf{a}_x , \mathbf{a}_y and \mathbf{a}_z with \mathbf{a}_r , \mathbf{a}_θ and \mathbf{a}_ϕ are given by

$$\begin{aligned} \mathbf{a}_x \cdot \mathbf{a}_r &= \sin \theta \cos \phi \\ \mathbf{a}_x \cdot \mathbf{a}_\theta &= \cos \theta \cos \phi \\ \mathbf{a}_x \cdot \mathbf{a}_\phi &= -\sin \phi \\ \mathbf{a}_y \cdot \mathbf{a}_r &= \sin \theta \sin \phi \\ \mathbf{a}_y \cdot \mathbf{a}_\theta &= \cos \theta \sin \phi \\ \mathbf{a}_y \cdot \mathbf{a}_\phi &= \cos \phi \\ \mathbf{a}_z \cdot \mathbf{a}_r &= \cos \theta \\ \mathbf{a}_z \cdot \mathbf{a}_\theta &= -\sin \theta \\ \mathbf{a}_z \cdot \mathbf{a}_\phi &= 0 \end{aligned}$$

Here,

$$\begin{aligned} A_r &= A_x \sin \theta \cos \phi + A_y \sin \theta \sin \phi + A_z \cos \theta \\ A_\theta &= A_x \cos \theta \cos \phi + A_y \cos \theta \sin \phi - A_z \sin \theta \\ A_\phi &= -A_x \sin \phi + A_y \cos \phi \end{aligned}$$

The point $A(x, y, z) = A(\rho, \phi, z) = A(r, \theta, \phi)$ in Cartesian, cylindrical and spherical coordinate systems is shown in a single Figure 1.4 to explain the concept at a glance.

$$\rho = r \sin \theta$$

$$\phi = \phi$$

$$z = r \cos \theta$$

$$r = \sqrt{\rho^2 + z^2}$$

$$\theta = \tan^{-1} \frac{r}{z}$$

$$\phi = \phi$$

The unit vectors of spherical coordinates in terms of Cartesian coordinates are given by

$$\mathbf{a}_r = \sin \theta \cos \phi \mathbf{a}_x + \sin \theta \sin \phi \mathbf{a}_y + \cos \theta \mathbf{a}_z$$

$$\mathbf{a}_\theta = \cos \theta \cos \phi \mathbf{a}_x + \cos \theta \sin \phi \mathbf{a}_y - \sin \theta \mathbf{a}_z$$

$$\mathbf{a}_\phi = -\sin \phi \mathbf{a}_x + \cos \phi \mathbf{a}_y$$

A vector $\mathbf{A} = (A_x, A_y, A_z)$ is expressed in spherical coordinates as

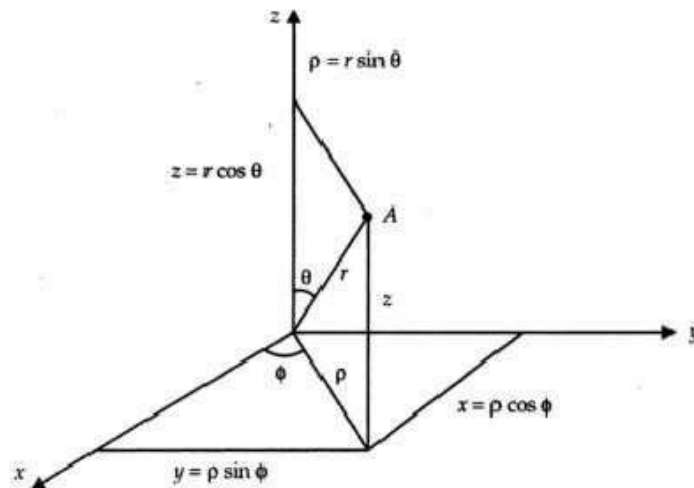
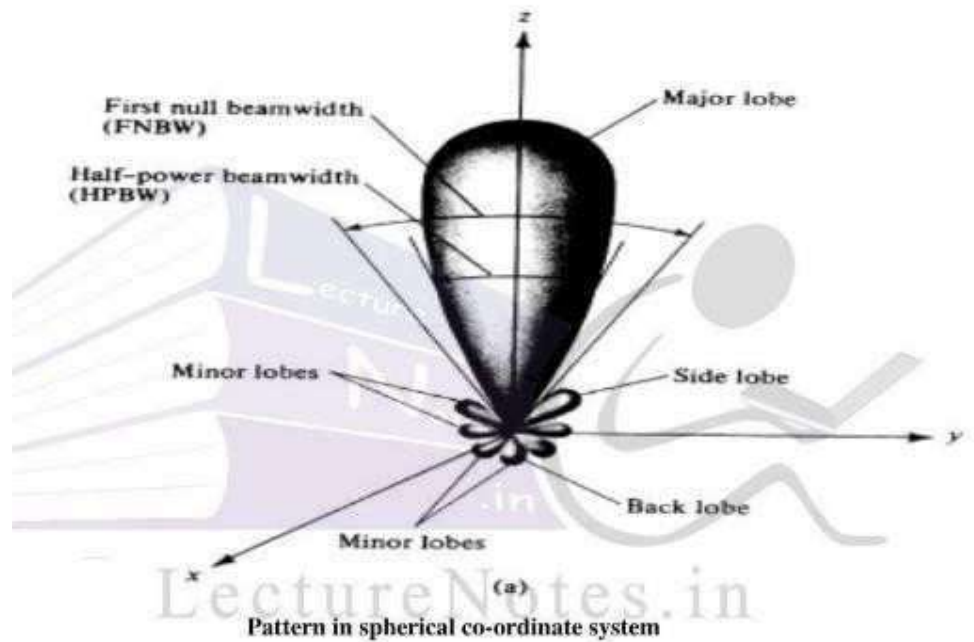

Figure 1.4 Coordinates in all the three systems

Pattern lobes and beam widths



The relations for differential length, area and volume are given in Table 1.1.

Table 1.1 Differential quantities in different coordinates

Coordinate System	dL	dS	dV
Cartesian	$dx \mathbf{a}_x + dy \mathbf{a}_y + dz \mathbf{a}_z$	$dx dy \mathbf{a}_z$ or $dy dz \mathbf{a}_x$ or $dz dx \mathbf{a}_y$	$dx dy dz$
Cylindrical	$d\rho \mathbf{a}_\rho + \rho d\phi \mathbf{a}_\phi + dz \mathbf{a}_z$	$\rho d\rho d\phi \mathbf{a}_z$ or $\rho d\phi dz \mathbf{a}_\rho$ or $d\rho dz \mathbf{a}_\phi$	$\rho d\rho d\phi dz$
Spherical	$dr \mathbf{a}_r + r d\theta \mathbf{a}_\theta + r \sin\theta d\phi \mathbf{a}_\phi$	$r dr d\theta \mathbf{a}_\phi$ or $r \sin\theta dr d\phi \mathbf{a}_\theta$ or $r^2 \sin\theta d\theta d\phi \mathbf{a}_r$	$r^2 \sin\theta dr d\theta d\phi$

The relations between the polar coordinates, (ρ, ϕ) and (x, y) of Cartesian Coordinates are

$$x = \rho \cos \phi$$

$$y = \rho \sin \phi$$

$$\rho = \sqrt{x^2 + y^2}$$

$$\phi = \tan^{-1} \left(\frac{y}{x} \right)$$

$$dxdy = \rho d\rho d\phi.$$

1.9 DECIBEL AND NEPER CONCEPTS

Decibel (dB) is defined as ten times the common logarithm of the power

ratio. That is, $1\text{dB} \equiv 10 \log_{10} \left(\frac{P_1}{P_2} \right)$



If P_1 and P_2 are input and output powers respectively of an electric circuit, then dB is negative if $P_2 > P_1$. This indicates power loss. If $P_1 > P_2$, dB is positive. This indicates power gain.

Decibel has no dimensions and it is used to express the ratio of two powers, voltages, currents or sound intensities.

One Bel (B) is equal to 10 decibels.

When input and output currents and voltages are known, we have

$$\begin{aligned} 1 \text{ dB} &= 20 \log_{10} \left(\frac{V_2}{V_1} \right) \\ &= 20 \log_{10} \left(\frac{I_2}{I_1} \right) \end{aligned}$$

Neper (NP) It has no dimensions and it is used to express the ratio of powers in communications.

A Neper is defined as the natural logarithm of the square root of the power ratio.



That is, $1\text{Np} \equiv \log_e \sqrt{\frac{P_2}{P_1}} = \frac{1}{2} \log_e \left(\frac{P_2}{P_1} \right)$

It's a 3-D pattern to represent field radiation pattern, spherical co-ordinate system is most suitable.

r' indicates the distance from antenna located at origin to the distance point P. The field intensity at point P is proportional to the distance r' . From the above fig. it is clear that field pattern consists of main lobe in z-direction where $\theta=0$ (which represents maximum radiation in that direction) then minor lobes on the sides (which are also called side lobes) and nulls between different lobes indicating minimum or zero radiation.

The pattern consists a small lobe exactly opposite to the main lobe which is called back lobe. The field radiation pattern can be expressed completely w.r.t. field intensity and polarization using 3 factors.

- (1) $E_{\theta}(\theta, \phi) \rightarrow$ The θ -component of the electric field as a function of angles θ and ϕ (v/m)
- (2) $E_{\phi}(\theta, \phi) \rightarrow$ The ϕ -component of electric field as a function of angle θ and ϕ (v/m)
- (3) $\delta_{\theta}(\theta, \phi)$ or $\delta_{\phi}(\theta, \phi) \rightarrow$ The phase angles of both the field components (deg. Or rad.)

The field pattern is expressed in terms of relative field pattern which is commonly called normalized field pattern. The normalized field pattern is defined as the ration of the field component to its max. value.

Normalized field pattern is a dimensionless quantity with max. value =1.

The normalized field patterns for θ and ϕ components of Electric Field are given as

$$E_{\theta n}(\theta, \phi) = E_{\theta}(\theta, \phi) / E_{\theta}(\theta, \phi)_{\max}$$

$$\text{Similarly } E_{\phi n}(\theta, \phi) = E_{\phi}(\theta, \phi) / E_{\phi}(\theta, \phi)_{\max}$$

We don't go for 3D pattern design instead we are preferring polar plots of the relative magnitude of the field in any desired plane are sketched.

These polar plots are plotted in two planes – one containing the antenna and the other normal to it. These planes are called –*Principle plans and the two plots or patterns are called Principle plan patterns.*” These patterns are obtained by plotting the magnitude of the normalized field strengths. When the magnitude of the normalized field strength is plotted versus θ with constant ϕ . The pattern is called E-plane pattern or vertical pattern.

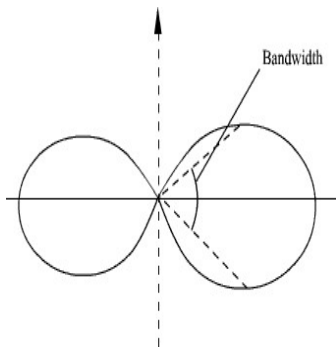

Figure 16 (a) Principal E plane pattern

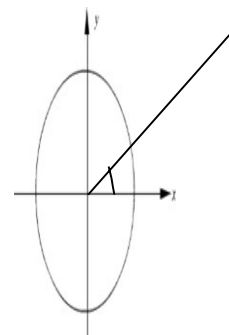
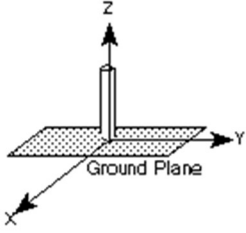

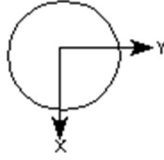
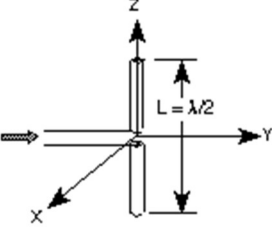
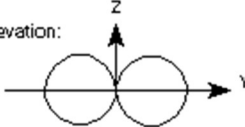
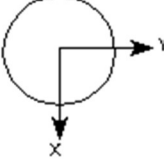
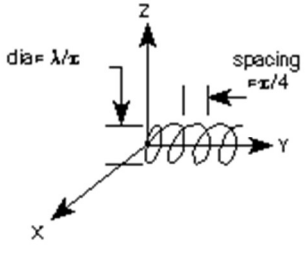

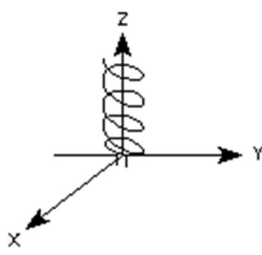

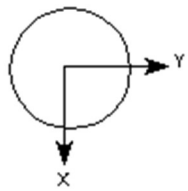

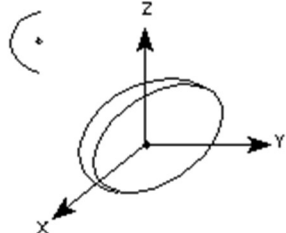
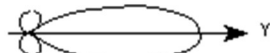
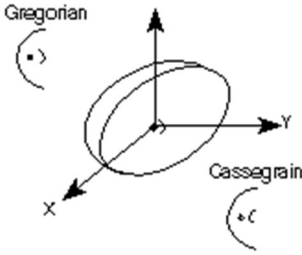

Figure 16(b) Principal H plane pattern

The bandwidth (3 dB beam width) can be found to be 90° in the E plane.

Different Antennas and its Radiation Patterns with their characteristics-

Antenna Type	Radiation Pattern	Characteristics
<p>MONOPOLE</p> 	<p>Elevation:</p>  <p>Azimuth:</p> 	<p>Polarization: Linear Vertical as shown</p> <p>Typical Half-Power Beamwidth 45 deg x 360 deg</p> <p>Typical Gain: 2-6 dB at best</p> <p>Bandwidth: 10% or 1:1:1</p> <p>Frequency Limit Lower: None Upper: None</p> <p>Remarks: Polarization changes to horizontal if rotated to horizontal</p>
<p>$\lambda/2$ DIPOLE</p> 	<p>Elevation:</p>  <p>Azimuth:</p> 	<p>Polarization: Linear Vertical as shown</p> <p>Typical Half-Power Beamwidth 80 deg x 360 deg</p> <p>Typical Gain: 2 dB</p> <p>Bandwidth: 10% or 1:1:1</p> <p>Frequency Limit Lower: None Upper: 8 GHz (practical limit)</p> <p>Remarks: Pattern and lobing changes significantly with L/λ. Used as a gain reference < 2 GHz.</p>

Antenna Type	Radiation Pattern	Characteristics
<p>AXIAL MODE HELIX</p> 	<p>Elevation & Azimuth</p> 	<p>Polarization: Circular Left hand as shown</p> <p>Typical Half-Power Beamwidth: 50 deg x 50 deg</p> <p>Typical Gain: 10dB</p> <p>Bandwidth: 52% or 1.7:1</p> <p>Frequency Limit Lower: 100 MHz Upper: 3 GHz</p> <p>Remarks: Number of loops >3</p>
<p>NORMAL MODE HELIX</p> 	<p>Elevation:</p>  <p>Azimuth:</p> 	<p>Polarization: Circular - with an ideal pitch to diameter ratio.</p> <p>Typical Half-Power Beamwidth: 60 deg x 360 deg</p> <p>Typical Gain: 0 dB</p> <p>Bandwidth: 5% or 1.05:1</p> <p>Frequency Limit Lower: 100 MHz Upper: 3 GHz</p>

Antenna Type	Radiation Pattern	Characteristics
<p>PARABOLIC (Prime)</p> 	<p>Elevation & Azimuth</p> 	<p>Polarization: Takes polarization of feed</p> <p>Typical Half-Power Beamwidth: 1 to 10 deg</p> <p>Typical Gain: 20 to 30 dB</p> <p>Bandwidth: 33% or 1.4:1 limited mostly by feed</p> <p>Frequency Limit Lower: 400 MHz Upper: 13+ GHz</p>
<p>PARABOLIC</p> <p>Gregorian</p>  <p>Cassegrain</p>	<p>Elevation & Azimuth</p> 	<p>Polarization: Takes polarization of feed</p> <p>Typical Half-Power Beamwidth: 1 to 10 deg</p> <p>Typical Gain: 20 to 30 dB</p> <p>Bandwidth: 33% or 1.4:1</p> <p>Frequency Limit Lower: 400 MHz Upper: 13+ GHz</p>

BEAM AREA or BEAM SOLID ANGLE (\check{A}_A):-

In polar two-dimensional coordinates an incremental area dA on the surface of sphere is the product of the length $r d\theta$ in the θ direction and $r \sin \theta d\Phi$ in the Φ direction as shown in figure.

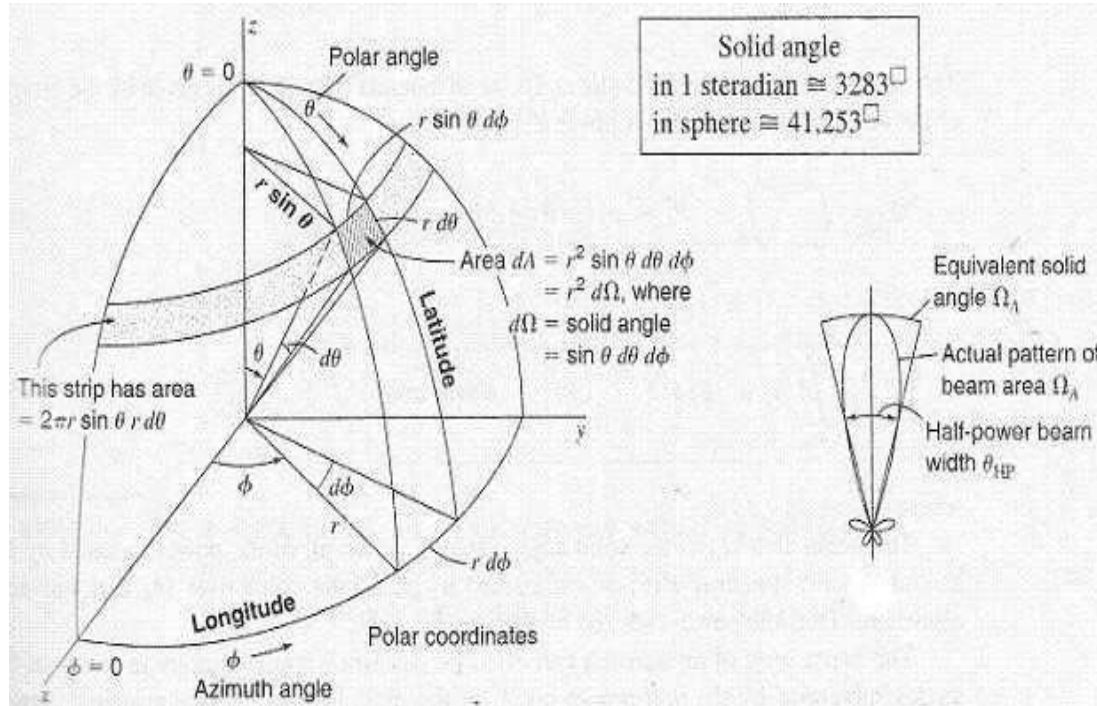
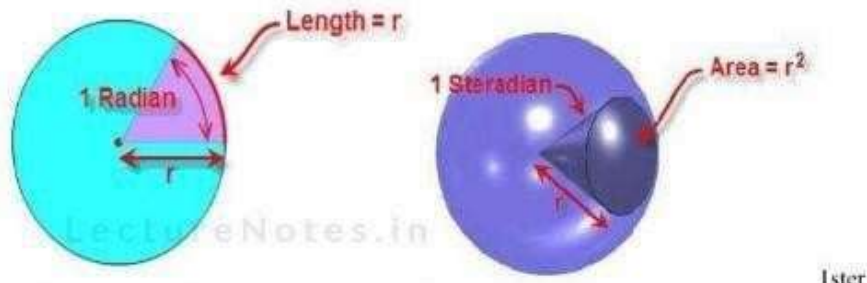

Figure 2: radian and steradian



$$\begin{aligned} \text{steradian} &= (1 \text{ radian})^2 \\ &= (180/\pi)^2 \\ &= 3282.8 \text{ Square degrees} \end{aligned}$$

The infinitesimal area ds on a surface of a sphere of radius r in spherical coordinates (with θ as vertical angle and Φ as azimuth angle) is

$$ds = r^2 \sin \theta d\theta d\phi$$

Ister

Thus

$$dA = (rd\theta) (r \sin\theta d\Phi) = r^2 d\Omega = dS$$

Where,

$$d\Omega = \text{solid angle expressed in steradians.} = \sin\theta d\theta d\Phi \text{ steradian}$$

The area of the strip of width $r d\theta$ extending around the sphere at a constant angle θ is given by $(2\pi r \sin\theta) (r d\theta)$. Integrating this for θ values from 0 to π yields the area of the sphere. Thus, Area of sphere = $2\pi r^2$

$$= 2\pi r^2 \int_{\theta=0}^{\pi} \sin\theta d\theta = 4\pi r^2$$

Where,

$$4\pi = \text{Solid angle subtended by a sphere}$$

The beam area or beam solid angle or Ω_A of an antenna is given by the integral of the normalized power pattern over a sphere

$$\begin{aligned} \text{Beam area, } \Omega_A &= \int_{\Phi=0}^{2\pi} \int_{\theta=0}^{\pi} P_n(\theta, \Phi) \sin\theta d\theta d\Phi \\ &= \int_{\Phi=0}^{2\pi} \int_{\theta=0}^{\pi} P_n(\theta, \Phi) d\check{\Omega} \text{ steradian} \end{aligned}$$

$$\text{Where, } d\Omega = \sin\theta d\theta d\Phi$$

Many times $\check{\Omega}_A$ is described in terms of the angles subtended by half power points of the main lobe.

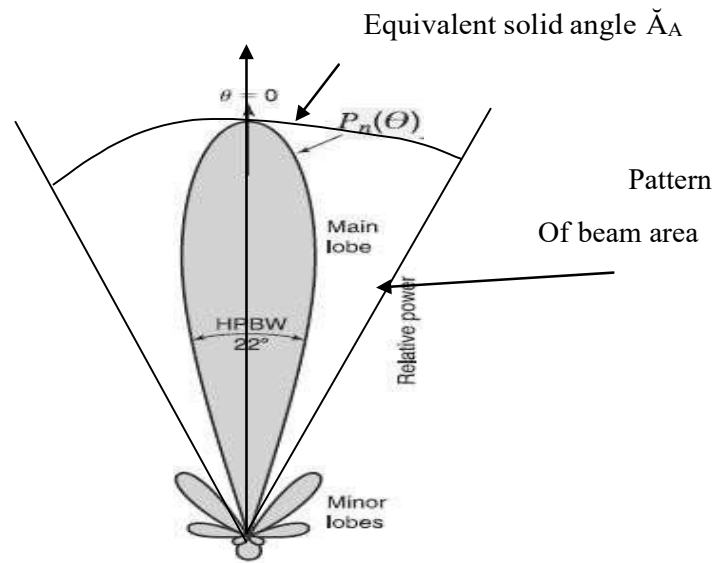
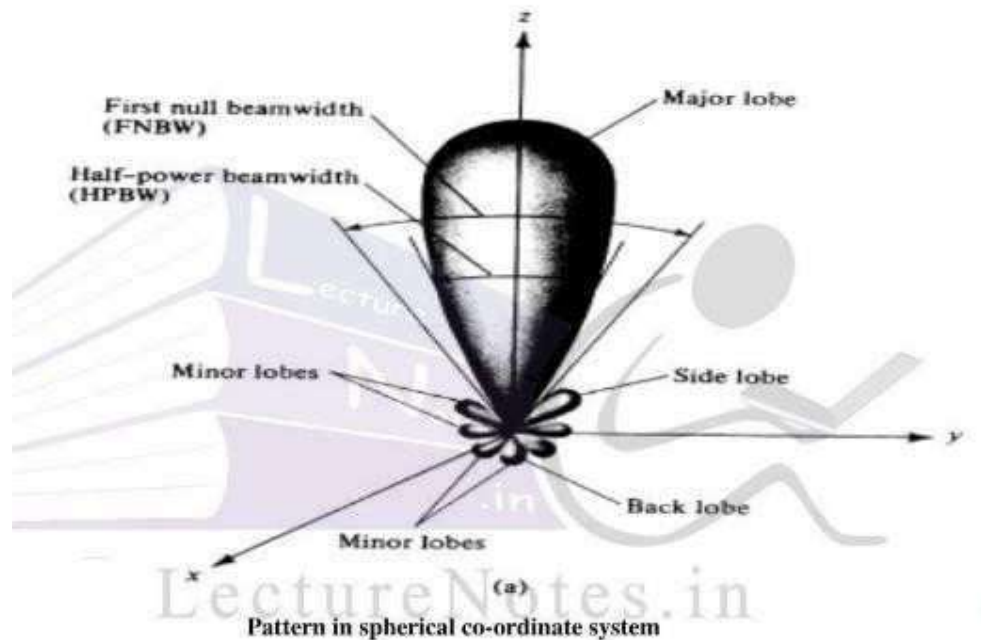

Fig. Representation of equivalent solid angle.

The beam area can be written as $\check{\Omega}_A \approx \theta_{HP} \check{\Phi}_{HP}$ steradian, θ_{HP} & $\check{\Phi}_{HP}$ half power beam widths neglecting minor lobes.

Pattern lobes and beam widths



RADIATION INTENSITY:-

The power radiated from an antenna per unit solid angle is called the radiation intensity U (watts per steradian or per square degree). The normalized power pattern of the previous section can also be expressed in terms of this parameter as the ratio of the radiation intensity $U(\theta, \Phi)$, as a function of angle, to its maximum value. Thus,

$$P_n(\theta, \Phi) = U(\theta, \Phi) / U(\theta, \Phi)_{\max} = S(\theta, \Phi) / S(\theta, \Phi)_{\max}.$$

Where as the Poynting vector S depends on the distance from the antenna (varying inversely as the square of the distance), the radiation intensity U is independent of the distance, assuming in both cases that we are in the far field of the antenna.

The total power radiated can be expressed in terms of radiation intensity

$$P_{\text{rad}} = \int_{\theta=0}^{\pi} \int_{\phi=0}^{2\pi} U(\theta, \phi) \sin\theta \, d\theta \, d\phi$$

* $U(\theta, \phi)$ is also time average power unit solid angle then

$$U_{\text{avg}} = \frac{P_{\text{rad}}}{4\pi}$$

Average radiation intensity

Using radiation intensity, normalised power pattern can be calculated as the ratio of $U(\theta, \phi)$ and its max. value $U(\theta, \phi)_{\max}$.

$$P_n(\theta, \phi) = \frac{U(\theta, \phi)}{U(\theta, \phi)_{\max}}$$

BEAM EFFICIENCY :-

The beam area $\check{\Omega}_A$ (or beam solid angle) consists of the main beam area (or solid angle) $\check{\Omega}_M$ plus the minor-lobe area (or solid angle) $\check{\Omega}_m$. Thus,

$$\check{\Omega}_A = \check{\Omega}_M + \check{\Omega}_m$$

The ratio of the main beam area to the (total) beam area is called the (main) beam efficiency $\check{\check{A}}_M$. Thus,

$$\check{\check{A}}_M = \frac{\text{POWER TRANSMITTED OR RECEIVED WITH IN THE CONE ANGLE } \theta_1}{\text{POWER TRANSMITTED OR RECEIVED BY ANTENNA}}$$

Where θ_1 = half angle of the cone within which the percentage of total power is forced. Mathematically beam efficiency is given by

$$BE = \frac{\int_{\phi=0}^{2\pi} \int_{\theta=0}^{\theta_1} \check{\Omega} \sin\theta \, d\theta \, d\phi}{\int_{\phi=0}^{2\pi} \int_{\theta=0}^{\pi} \check{\Omega} \sin\theta \, d\theta \, d\phi}$$

The beam efficiency can be expressed in terms of the main beam area ($\check{\Omega}_M$) and total area ($\check{\Omega}_A$), then the beam efficiency is defined as the ratio of the main beam area to the total beam area, given by

$$\text{Beam Efficiency} = \check{\check{A}}_M = \check{\Omega}_M / \check{\Omega}_A \text{ (dimensionless)}$$

$$\text{And } \check{\Omega}_A = \check{\Omega}_M + \check{\Omega}_m \text{ (main beam area + minor lobe area)}$$

$$1 = \check{\Omega}_M / \check{\Omega}_A + \check{\Omega}_m / \check{\Omega}_A = \check{\check{A}}_M + \check{\check{A}}_m$$

The ratio of the minor-lobe area ($\check{\Omega}_m$) to the (total) beam area is called the stray factor.

Thus,

$$\text{Stray factor} = \check{\check{A}}_m = \check{\Omega}_m / \check{\Omega}_A.$$

DIRECTIVITY:-

Directivity of an antenna or array is a measure of the antenna's ability to focus the energy in one or more specific directions. You can determine an antenna's directivity by looking at its radiation pattern. In an array propagating a given amount of energy, more radiation takes place in certain directions than in others. The elements in the array can be arranged so they change the pattern and distribute the energy more evenly in all directions. The opposite is also possible. The elements can be arranged so the radiated energy is *focused* in one direction. The elements can be considered as a group of antennas fed from a common source.

It is defined as the ratio of maximum radiation intensity of subject or test antenna to the radiation intensity of an isotropic antenna.

(or)

Directivity is defined as the ratio of maximum radiation intensity to the average radiation intensity.

Directivity (D) in terms of total power radiated is,

$$D = 4\pi \times \frac{\text{MAXIMUM RADIATION INTENSITY}}{\text{TOTAL POWER RADIATED}}$$

GAIN: -

Gain is a parameter which measures the degree of directivity of the antenna's radiation pattern. A high-gain antenna will preferentially radiate in a particular direction. Specifically, the *antenna gain*, or *power gain* of an antenna is defined as the ratio of the intensity (power per unit surface) radiated by the antenna in the direction of its maximum output, at an arbitrary distance, divided by the intensity radiated at the same distance by a hypothetical isotropic antenna.

$$\text{GAIN} = \frac{\text{INTENSITY RADIATED BY THE ANTENNA IN THE DIRECTION OF MAX. OUTPUT AT AN ARBITRARY DISTANCE}}{\text{INTENSITY RADIATED AT THE SAME DISTANCE BY A HYPOTHETICAL ISOTROPIC ANTENNA}} \quad \text{---(1)}$$

As we mentioned earlier, some antennas are highly directional. That is, they propagate more energy in certain directions than in others. The ratio between the amount of energy propagated in these directions and the energy that would be propagated if the antenna

were not directional is known as antenna GAIN. The gain of an antenna is constant, whether the antenna is used for transmitting or receiving.

Directivity function describes the variation of the radiation intensity. The directivity function

$D(\theta, \phi)$ describes the variation of the radiation intensity. The directivity function $D(\theta, \phi)$ is defined by

$$D(\theta, \phi) = \frac{\text{Power radiated per unit solid angle}}{\text{Average power radiated per unit solid angle}} \quad \text{-----}(2)$$

If P_r is the radiated power, the $\frac{dP_r}{dA}$ gives the amount of power radiated per unit solid angle. Had this power beam uniformly radiated in all directions then average power radiated per unit solid angle is $\frac{P_r}{4\pi}$

$$D(\theta, \phi) = \frac{\frac{dP_r}{d\Omega}}{\frac{P_r}{4\pi}} = 4\pi \times \frac{dP_r}{P_r} \quad \text{-----}(3)$$

The maximum of directivity function is called the directivity.

In defining directivity function total radiated power is taken as the reference. Another parameter called the gain of an antenna is defined in the similar manner which takes into account the total input power rather than the total radiated power is used as the reference. The amount of power given as input to the antenna is not fully radiated.

$$P_r = \eta P_{in} \quad \text{-----}(4)$$

where η is the radiation efficiency of the antenna.

The gain of the antenna is defined as

$$G(\theta, \phi) = 4\pi \frac{\text{RADIATED POWER PER UNIT SOLID ANGLE}}{\text{INPUT POWER}} \quad \text{-----}(5)$$

$$G(\theta, \phi) = \eta D(\theta, \phi) \quad \text{-----}(6)$$

The maximum gain function is termed as gain of the antenna.

Another parameter which incorporates the gain is effective isotropic radiated power or EIRP which is defined as the product of the input power and maximum gain or simply the gain. An antenna with a gain of 100 and input power of 1 W is equally effective as an antenna having a gain of 50 and input power 2 W.

DIRECTIVE GAIN [$G_D(\theta, \phi)$] and DIRECTIVITY[D]:-

- An isotropic antenna is the omni directional antenna. If the antenna were isotropic i.e., if it were to radiate uniformly in all directions, then the power density at all the points on the surface of a sphere will be same.
- The average power is expressed in terms of radiated power as

$$P_{avg} = P_{rad}/4\pi r^2 \text{ w/m}^2$$

- The directive gain is defined as the ratio of the power density $P_d(\theta, \phi)$ to the average power radiated.
- For isotropic antenna, the value of the directive gain is unity.

$$G_D(\theta, \phi) = P_d(\theta, \phi)/P_{avg} = P_d(\theta, \phi)/P_{rad}/4\pi r^2$$

$$\text{Or}$$

$$G_D(\theta, \phi) = \frac{P_d(\theta, \phi)}{P_{rad}/4\pi r^2} r^2$$

- The numerator in the above ratio is the radiation intensity while the denominator is the average value of radiation intensity.
- So directive gain

$$G_D(\theta, \phi) = \frac{U(\theta, \phi)}{U_{avg}} = 4\pi \frac{U(\theta, \phi)}{P_{rad}}$$

- Thus the directive gain can be defined as the measure of the concentration of the radiated power in a particular direction of (θ, ϕ) .
- The ratio of the max. Power density to the average power radiated is called max. Directive gain or directivity of the antenna, denoted by G_{Dmax} . Or D
-

$$D = G_{Dmax} = \frac{P_{dmax}}{P_{rad}/4\pi r^2}$$

Directivity can also be defined as ,

$$D = G_{Dmax} = U_{max} / U_{avg} = 4\pi U_{max} / P_{rad}$$

Directivity is a dimensionless quantity and can also be expressed in terms of Electric Field Intensity as

$$D = \frac{G_{Dmax}}{G_0} = \frac{4\pi |E_{max}|^2 / 2\pi \int_0^{2\pi} \int_0^\pi |E(\theta, \phi)|^2 \sin\theta d\theta d\phi}{4\pi |E_0|^2 / 2\pi \int_0^{2\pi} \int_0^\pi \sin\theta d\theta d\phi} = \frac{4\pi |E_{max}|^2}{\int_0^{2\pi} \int_0^\pi |E(\theta, \phi)|^2 \sin\theta d\theta d\phi}$$

We know that,

$$P_{avg} = \frac{1}{4\pi} \int_0^{2\pi} \int_0^\pi P(\theta, \phi) \sin\theta d\theta d\phi$$

$$\text{And } d\Omega = \sin\theta d\theta d\phi$$

$$\text{Therefore } P_{avg} = \frac{1}{4\pi} \int_0^{2\pi} \int_0^\pi P(\theta, \phi) d\Omega \text{ W/sr}$$

$$\text{Hence, } D = \frac{P_{dmax}}{P_{avg}} = \frac{1}{4\pi} \frac{P_{dmax}}{\int_0^{2\pi} \int_0^\pi P(\theta, \phi) d\Omega} \quad \text{or } D = \frac{1}{\int_0^{2\pi} \int_0^\pi \frac{P(\theta, \phi)}{P_{dmax}} d\Omega}$$

But $P(\theta, \phi) / P(\theta, \phi)_{max} = P_n(\theta, \phi) = \text{Normalised power pattern}$

$$D = \frac{4\pi}{\int_0^{2\pi} \int_0^\pi P_n(\theta, \phi) d\Omega} = \frac{4\pi}{\Omega_A}$$

If the half power beam widths of an antenna are known then,

$$D = 41253^{db} / \theta_{HP} \phi_{HP}$$

Where $41253^{db} = \text{no. of square degrees in sphere} = 4\pi \left(\frac{180}{\pi}\right)^2 \text{ square degrees}$

$\theta_{HP}^\circ = \text{HPBW in one principle plane}$

$\phi_{HP}^\circ = \text{HPBW in other principle plane.}$

Above equation is obtained by neglecting minor lobes. If we consider minor lobes too, then the approximation formula for directivity is

$$D = 40000^{d/10} / \theta_{HP} \phi_{HP}$$

DIRECTIVITY AND RESOLUTION:-

The resolution of an antenna is defined as half of the beam width between first nulls,

$$\text{Resolution} = \frac{FNBW}{2}$$

But half the beam width between first nulls is approximately equal to the HPBW of an antenna.

$$HPBW \approx \frac{FNBW}{2}$$

*Practically, HPBW is slightly less than FNBW/2

Also we know that, the antenna beam area is given by the product of two half power beam width in two principle planes.

$$\check{A}_A = \theta_{HP} \phi_{HP} \approx \left(\frac{FNBW}{2} \right)_{\theta} \left(\frac{FNBW}{2} \right)_{\phi}$$

If there are 'N' no. of point sources of radiation distributed uniformly, then antenna resolve those and is given by

$$N = \frac{4\pi}{\Omega_A}; \quad \check{A}_A = \text{beam area expressed in sr.}$$

But by the definition, the directivity of antenna is defined as, $D = \frac{4\pi}{\Omega_A}$

Hence $D = N \rightarrow$ so ideally no. of point sources resolved by an antenna is equal to directivity of an antenna.

The resolution of antenna is also called Rayleigh Resolution. The expression $D = \frac{4\pi}{\Omega_A}$

represents no. of beam area of antenna pattern. $D = N$ represents no. of point sources resolved by antenna in the sky which is ideally equal to directivity of an antenna.

POEER GAIN [$G_P(\theta, \phi)$] AND RADIATION EFFICIENCY:

The practical antenna is made up of a conductor having finite conductivity. Hence we must consider ohmic power loss of the antenna. If the practical antenna has ohmic losses (I^2R) represented by P_{loss} , then the power radiated P_{rad} is less than the power radiated P_{rad} is less than the input power P_{in}

$$P_{\text{rad}} = \eta_r P_{\text{in}} ; \quad P_{\text{rad}} / P_{\text{in}} = \eta_r$$

Where η_r is radiation efficiency of an antenna

But the total input power to the antenna is $P_{\text{in}} = P_{\text{rad}} + P_{\text{loss}}$

$$\text{So, } \eta_r = \frac{P_{\text{rad}}}{P_{\text{rad}} + P_{\text{loss}}}$$

The power radiated and the ohmic power loss can be expressed in terms of r.m.s. current as

$$P_{\text{rad}} = I_{\text{rms}}^2 R_{\text{rad}} \quad \text{and} \quad P_{\text{loss}} = I_{\text{rms}}^2 R_{\text{loss}}$$

Then the radiation efficiency is given by

$$\eta_r = \frac{R_{\text{rad}}}{R_{\text{rad}} + R_{\text{loss}}}$$

The ratio of the power radiated in a particular direction, ϕ , to the actual power input to the antenna is called power gain of antenna.

The power gain of the antenna denoted by $G_P(\theta, \phi)$, and is given by

$$G_P(\theta, \phi) = P_d(\theta, \phi) / P_{\text{in}}$$

The maximum power gain can be defined as the ratio of the max. Radiation intensity to the radiation intensity due to isotropic lossless antenna.

$$G_{\text{pmax}} = \frac{\text{Maximum radiation intensity}}{\text{Radiation intensity due to isotropic loss less antenna}}$$

$$G_{\text{pmax}} = \frac{U_m}{\left(\frac{in}{4\pi}\right)}$$

But the maximum radiation intensity is given by

$$U_{\max} = \frac{\text{Prad}}{4\pi} G_{D\max} = \frac{5r P_{in}}{4\pi} G_{D\max} = \frac{5r P_{in}}{4\pi} D$$

Substituting value of U_{\max} in the expression for maximum power gain

$$G_{P\max} = \frac{\eta r (P_{in}/4\pi) G_{D\max}}{(P_{in}/4\pi)}$$

$$G_{P\max} = \eta r G_{D\max} = \eta r D$$

For many practical antennas the radiation efficiency ηr is 100% then the maximum power gain is approx. Same as the directivity or the max, directional gain of the antenna.

Power gain & directional gain are expressed in (dB)

ANTENNA APERTURES:

EFFECTIVE APERTURE:

Aperture concept: Aperture of an Antenna is the area through which the power is radiated or receive. Concept of Apertures is most simply introduced by considering a Receiving Antenna. Let receiving antenna be a rectangular Horn immersed in the field of uniform plane wave as shown.

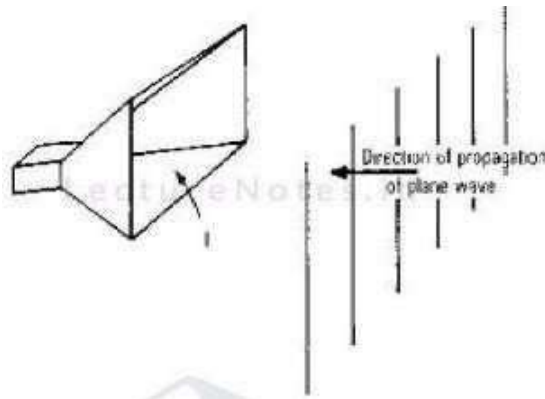

Let the pointing vector or power density of the plane wave be S watts/sq-m and let the area or physical aperture be A_p sq-m. If the horn extracts all the power from the wave over its entire physical Aperture A_p . Power absorbed is given by

$$P = S A_p = \left(\frac{E^2}{Z}\right) A_p \text{ Watts}$$

Where S is pointing impedance of medium

Z is intrinsic impedance of medium

E is rms value of electric field

But the field response of horn is not uniform across A_p because E at side walls must equal zero. Thus effective Aperture A_e of the horn is less than A_p .

$$\text{Aperture efficiency is defined as } \ddot{A}_{ap} = \frac{A_p}{A_e}$$

The effective antenna aperture is the ratio of the available power at the terminals of the antenna to the power flux density of a plane wave incident upon the antenna, which is matched to the antenna in terms of polarization. If no direction is specified, the direction of maximum radiation is implied. Effective Aperture (A_e) describes the effectiveness of an antenna in receiving mode, it is ration of power delivered to receiver to incident power density.

Effective aperture is defined as the ratio of power received in the load to the average power density produced at the point

$$A_e = \frac{P_{received}}{P_{avg.}} \text{ m}^2 \dots\dots\dots (1)$$

Power received by the antenna may be denoted by P_R . An antenna should have maximum useful area to extract energy and thus the max. effective aperture is obtained when power received is maximum, denoted by A_{em} . Let us calculate effective aperture for the Herzian dipole, when the Hertzian dipole is used as the receiving antenna, it extracts power from the incident waves and delivers it to the load, producing voltage in it. The voltage induced in the antenna is given by

$$V_{oc} = E \text{ dL} \dots\dots\dots (2)$$

Where, $|E|$ is the magnitude of Electric Field Intensity produced at the receiving point and dL is the length of the Hertzian dipole. Then the current flowing the load is given by

$$I = \frac{V_{oc}}{Z + Z_L} \dots\dots\dots (3)$$

For the maximum power transfer condition, load is selected as the complex conjugate of the antenna impedance ($Z_L = Z^*$), substituting the values of impedance Z and Z_L , the current flowing can be written as,

$$I = \frac{V_{oc}}{R_{rad} + jX + (R_{rad} - jX)} = \frac{V_{oc}}{2R_{rad}} \dots\dots\dots (4)$$

Then the power delivered to the load is given by

$$P_R = I_{rms}^2 R_{rad} = \frac{V_{oc}^2}{2} \frac{R_{rad}}{R_{rad}^2}$$

$$P_R = V_{oc}^2 / 8 R_{rad}; \text{ substituting the value of } V_{oc} \text{ from eq (2) we get}$$

$$P_R = E^2 \text{ dL}^2 / 8 R_{rad} \dots\dots\dots (5)$$

The maximum effective aperture is given by

$$A_{em} = \frac{\text{Max .power received}}{\text{Average power density}} = \frac{PR_{max.}}{P_{avg.}}$$

$$A_{em} = \frac{\frac{2 dL^2}{8 R_{rad}}}{\frac{1 E^2}{250}}$$

$$A_{em} = dL^2 \eta_0 / 4 R_{rad}$$

Substituting value of Rrad and η_0 we get,

$$A_{em} = \frac{dL^2 120\pi}{4 80\pi^2 \frac{2}{\lambda}}$$

$$A_{em} = 3\lambda^2/8\pi = 1.5 \lambda^2/4\pi \dots\dots\dots(6)$$

Above equation represents the max, effective aperture of the Hertzian dipole. But the directivity of Hertzian dipole is 1.5.

Hence, we can rewrite the expression for the max. effective aperture as

$$A_{em} = GD_{max} \cdot \frac{\lambda^2}{4\pi} \dots\dots\dots(7)$$

The equivalent aperture of a lossless antenna may be defined in terms of the maximum directivity as

$$A_{em} = (\lambda^2/4\pi) D_0 \dots\dots\dots(8)$$

DIFFERENT TYPES OF ANTENNA APERTURES:-

In receiving antenna, effective aperture is very important parameter as it indicated the ability of an antenna to extract energy from EM waves. The various types of apertures are:-

- (a) **Scattering Aperture(As):-** The scattering aperture is defined as the ration of power received by radiation resistance Rrad to the average power density at point

$A_s = I_{rms}^2 \cdot R_{rad} / P_{avg} = I_{rms}^2 \cdot R_{rad} / P_{avg}$ using an equivalent circuit of antenna

$$I_{rms} = \frac{VA}{\sqrt{R_L + R_A} \sqrt{X_L + X_A}}$$

$$A_s = \frac{VA^2 R_{rad}}{\sqrt{R_L + R_A} \sqrt{X_L + X_A} P_{avg}}$$

For max. power transfer condition, $R_L = R_A = R_{rad}$ assuming $R_{loss} = 0$ and $X_L = -X_A$, we get

$$(A_s)_{max} = V_A^2 / 4 R_{rad} P_{avg} = (A_e)_{max}$$

Thus it is observed that under maximum power transfer condition the $(A_s)_{max}$, of antenna is same as $(A_e)_{max}$.

The ratio of scattering aperture of an antenna to its effective aperture is known as scattering ratio, denoted by β and its value lies between 0 and ∞

$$\beta = \frac{A_s}{A_e}$$

- (b) **Loss Aperture (Al):-** It is aperture of an antenna related to the loss resistance of an antenna. It is defined as the ratio of power dissipated by the loss resistance of an antenna to the average power density at a point. It is called loss aperture and denoted by A_l .

$$A_l = I_{rms}^2 \cdot R_{loss} / P_{avg} = I_{rms}^2 \cdot R_{loss} / P_{avg}$$

Putting value of I_{rms} , we get alternative expression for A_l as

$$A_l = \frac{VA^2 \cdot R_{loss}}{\sqrt{R_L + R_A} \sqrt{X_L + X_A} P_{avg}}$$

But $R_A = R_{rad} + R_{loss}$

$$A_l = \frac{VA^2 \cdot R_{loss}}{\sqrt{R_L + R_{rad} + R_{loss}} \sqrt{X_L + X_A} P_{avg}}$$

- (c) **Collecting Aperture (Ac):-** The collecting aperture (A_c) is the sum of effective aperture scattering aperture and loss aperture of an antenna. Hence, we can write

$$A_c = A_e + A_s + A_l$$

$$A_c = I_{rms}^2 \cdot \frac{R_L}{P_{avg}} + I_{rms}^2 \cdot \frac{R_{rad}}{P_{avg}} + I_{rms}^2 \cdot \frac{R_{loss}}{P_{avg}}$$

$$A_c = I_{rms}^2 \cdot (R_L + R_{rad} + R_{loss}) / P_{avg}$$

P_{avg} is magnitude of average power density at a point.

Substituting value of I_{rms} the alternative expression for A_c is

$$A_c = \frac{V_A^2 \frac{R_L + R_{rad} + R_{loss}}{2 + X_L + X_A}}{P_{avg}} \quad \text{where } V_A^2 \text{ is } V_A^2$$

$$\text{where } \frac{[(R_L + R_{rad} + R_{loss})^2 + (X_L + X_A)^2]}{2 + X_L + X_A} P_{avg} = (R_L + R_{rad} + R_{loss})^2$$

- (d) **Physical Aperture:** The physical aperture (A_p) is the parameter which deals with the actual physical size or cross section of an antenna. A_p is defined as the actual physical cross section of an antenna normal to the direction of propagation of EM waves towards an antenna which is set for its max. response.

For large cross section antennas A_p is greater than A_e , for antennas like short dipole, $A_p < A_e$. When the losses are assumed to be zero, the physical aperture and effective aperture both are equal

$$A_p = A_e (P_{loss} = 0)$$

The ratio of max. $(A_e)_{max}$ to A_p is known as **Absorption ratio** denoted by γ , value lies between 0 and ∞

$$\gamma = (A_e)_{max} / A_p$$

It is the area that captures energy from a passing EM wave. An antenna with large aperture (A_e) has more gain than one with smaller aperture (A_e) since it captures more energy from a passing radio wave and can radiate more in that direction while transmitting.

FIELDS FROM OSCILLATING DIPOLE:-

Far Field due to an Alternating Current Element (Oscillating Dipole):-

With reference to Fig. 4-2 consider that a time varying current I is flowing in a very short and very thin wire of length dl in the z -direction (where dl tends to zero). This current is given by $I dl \cos \omega t$. Since the current is in the z direction, the current density J will have only a z -component (i.e., $J = J_z \hat{z}$). The vector magnetic potential A will also have only a z -component (i.e., $A = A_z \hat{z}$).

$$\text{Thus, } \nabla^2 A = \nabla^2 A_z = -\mu J_z \quad (1)$$

Though the cylindrical coordinate system can suitably accommodate the configuration of a filamentary current carrying conductor, wherein only the A_z component exists and the A_ρ and A_ϕ components are zero, but since the three-dimensional radiation problem needs to be tackled in spherical coordinate system, A_z is to be transformed to the spherical coordinate system. This transformation results in

$$A_r = A_z \cos \theta, \quad A_\theta = -A_z \sin \theta \quad \text{and} \quad A_\phi = 0 \quad (2)$$

In view of the relation $I dl = K ds = J dv$, for filamentary current, which we come across in the last topics, can be written as

$$A_z = \frac{\mu}{4\pi} \frac{I dl \cos \omega(t - r/v)}{r} \quad (3)$$

In view of (2) and (3),

$$A_r = \frac{\mu}{4\pi} \frac{I dl \cos \omega(t - r/v)}{r} \cos \theta \quad \text{and} \quad A_\theta = -\frac{\mu}{4\pi} \frac{I dl \cos \omega(t - r/v)}{r} \sin \theta \quad (4)$$

Further from the relation $B = \nabla \times A$, the components of $\nabla \times A$ are obtained as below.

$$(\nabla \times A)_r = \frac{1}{\sin \theta} \left[\frac{\partial}{\partial \theta} (\sin \theta A_\phi) - \frac{\partial A_\theta}{\partial \phi} \right] = B_r = 0 \quad (5a)$$

$$(\nabla \times A)_\theta = \left[\frac{1}{r \sin \theta} \frac{\partial A_r}{\partial \phi} - \frac{1}{r} \frac{\partial (r A_\phi)}{\partial r} \right] = B_\theta = 0 \quad (5b)$$

$$(\nabla \times A)_\phi = \frac{1}{r} \left[\frac{\partial}{\partial r} (r A_\theta) - \frac{\partial A_r}{\partial \theta} \right] = B_\phi = \mu H_\phi \quad (5c)$$

From (5), it can be noted that only H_ϕ survives. It can also be stated that ϕ derivative is zero (i.e., $\partial/\partial \phi \equiv 0$) for all field components due to the symmetry along ϕ . From (2) and (5c),

$$H_{\phi} = \frac{Idl \sin \theta}{4\pi} \left[-\frac{\omega}{rv} \sin \omega(t - r/v) + \frac{\cos \omega(t - r/v)}{r^2} \right] \quad (6)$$

From (1a) of sec. 4.2, $E = \frac{1}{c} \nabla \times H dt$

$$\text{Thus } E_r = \frac{1}{\epsilon} \int (\nabla \times H)_r dt \quad \text{and} \quad E_{\theta} = \frac{1}{\epsilon} \int (\nabla \times H)_{\theta} dt \quad (7)$$

Since $\nabla \times H = \frac{1}{r \sin \theta} \frac{\partial(H_{\phi} \sin \theta)}{\partial \theta} a_r - \frac{1}{r} \frac{\partial(rH_{\phi})}{\partial r} a_{\theta}$ its component in radial direction is given by

$$(\nabla \times H)_r = \frac{1}{r \sin \theta} \frac{\partial}{\partial \theta} \left[\frac{Idl}{4\pi} \sin^2 \theta \left\{ -\frac{\omega}{rv} \sin \omega(t - r/v) + \frac{\cos \omega(t - r/v)}{r^2} \right\} \right] = E_r \quad (8)$$

From (7) and (8),

$$E_r = \frac{Idl}{4\pi r} \cos \theta \left[\frac{\omega}{rv} \sin \omega(t - r/v) - \cos \frac{\omega(t - r/v)}{r^2} \right] \quad (9)$$

Putting $t' = t - r/v$

$$E_r = \frac{2Idl \cos \theta}{4\pi \epsilon} \left[\frac{\cos \omega t'}{r^2 v} + \frac{\sin \omega t'}{\omega r^3} \right] \quad (10a)$$

Similarly,

$$E_{\theta} = \frac{Idl \sin \theta}{4\pi \epsilon} \left[\frac{-\omega \sin \omega t'}{rv^2} + \frac{\cos \omega t'}{r^2 v} + \frac{\sin \omega t'}{\omega r^3} \right] \quad (10b)$$

H_{ϕ} can also be rewritten as

$$H_{\phi} = \frac{Idl \sin \theta}{4\pi} \left[\frac{\cos \omega t'}{r^2} - \frac{\omega \sin \omega t'}{rv} \right] \quad (11)$$

It can be noted that the magnitudes of the two bracketed terms in (11) will become equal if the following relation is satisfied:

$$\frac{1}{r^2} = \frac{\omega}{rv} \quad \text{or} \quad r = \frac{v}{\omega} = \frac{f\lambda}{2\pi f} = \frac{\lambda}{2\pi} \quad \text{or} \quad r \approx \frac{\lambda}{6} \quad (12)$$

From (12), it can be concluded that for $r < \lambda/6$, the induction field will dominate whereas for $r > \lambda/6$, the radiation field assumes more importance. Thus for $r \gg \lambda/6$, only the radiation field needs to be accounted.

The expressions of E_θ, E_r and H_ϕ given by (10) and (11) involve three types of terms, which represent three different types of fields. These are noted below:

1. The terms inversely proportional to r^3 represent electrostatic field. Such terms are involved in the expressions of E_θ and E_r
2. The terms inversely proportional to r^2 represent induction or near field. Such terms are involved in all the field components, i.e., in E_θ, E_r and H_ϕ .
3. Lastly, the terms which are inversely proportional only to r represent radiation (distant or far) field and are involved in the expressions of E_θ and H_ϕ .

FRONT TO BACK RATIO (FBR):-

FBR is defined as the power radiated in the desired direction to the power radiated in opposite direction.

$$\text{FBR} = \frac{\text{POWER RADIATED IN DESIRED DIRECTION}}{\text{POWER RADIATED IN OPPOSITE DIRECTION}}$$

The FBR value desired is very high as it is expected to have large radiation in the front or desired direction rather than that in the back or opposite direction.

The FBR depends on frequency of operation, so when frequency of an antenna changes, the FBR also changes. FBR also depends on the spacing between the antenna elements. If the spacing between the antenna elements increases the FBR decreases. The FBR also depends on the electrical length of the parasitic elements of the antenna.

FBR can be raised by diverting the gain of backward direction response of the antenna to the parasitic elements. The method of adjusting the electrical length of the parasitic element is called **tuning**. These higher FBR is obtained at the cost of gain from the opposite direction.

Practically FBR is important in case of receiving antennas rather than transmitting antennas. At the receiving antenna, adjustments are made in such a way to obtain max, FBR rather than max. gain.

RADIATION RESISTANCE:

The radiation resistance of an antenna is defined as the equivalent resistance that would dissipate the same amount power as is radiated by the antenna. For the elementary current element we have discussed so far. From equation (3.26) we find that radiated powerdensity

$$P_{av} = |I|^2 \eta_0 (dl)^2 K_0^2 \sin^2\theta / 32 \pi^2 r^2 a_r \quad .(1)$$

Radiated power :-

$$P_r = |I|^2 \eta_0 (dl)^2 K_0^2 \sin^2\theta / 32 \pi^2 r^2 \int_{\theta=0}^{\pi} \int_{\phi=0}^{2\pi} \sin^2\theta r^2 \sin\theta d\theta d\phi$$

$$= |I|^2 \eta_0 (dl)^2 K_0^2 \sin^2\theta / 32 \pi^2 \int_{\phi=0}^{2\pi} d\phi \int_{\theta=0}^{\pi} \sin^3\theta d\theta \dots\dots(2)$$

Where $\int_{\theta=0}^{\pi} \sin^3\theta d\theta = 2$ but here we have $\int_{\theta=0}^{\pi} \sin^3\theta d\theta = 2 \times \int_{\theta=0}^{\pi/2} \sin^3\theta d\theta = 2 \times 2/3$

$$P_r = |I|^2 \eta_0 (dl)^2 K_0^2 / 12 \pi \dots \dots \dots (3)$$

$$\text{Further } \frac{dP_r}{r} = P_r \sin^2 \theta \, d\theta \, d\phi \, r^2 \overset{\circ}{a}r = P_r \overset{\circ}{a}r \, r^2 \, d\overset{\circ}{A}$$

$$dP_r / d\overset{\circ}{A} = |I|^2 \eta_0 (dl)^2 K_0^2 \sin^2 \theta / 32 \pi^2 \dots \dots \dots (4)$$

From (3) and (4)

$$D(\theta, \phi) = 1.5 \sin^2 \theta$$

Directivity $D = D(\theta, \phi)_{\max}$ which occurs at $\theta = \pi/2$. If R_r is the radiation resistance of the

elementary dipole antenna, then

$$\frac{1}{2} |I|^2 R_r = P_r$$

Substituting P_r from eq(3) we get

$$R_r = \eta_0 / 6\pi (2\pi \frac{dl}{\lambda_0})^2 \dots \dots \dots (5)$$

Substituting η_0 as 120π

$$R_r = 480\pi^3 / 6\pi (\frac{dl}{\lambda_0})^2 \dots \dots \dots (6)$$

$$R_r = 480\pi^2 / 6\pi (\frac{dl}{\lambda_0})^2 \dots \dots \dots (7)$$

For such an elementary dipole antenna the principal E and H plane pattern are shown in Fig 16(a) and (b).

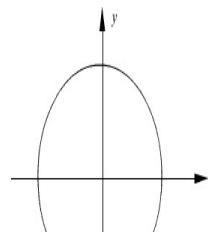
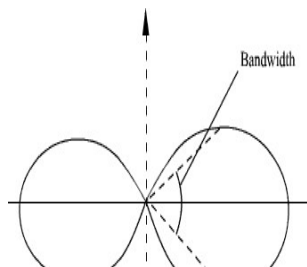

Figure16 (a) Principal E plane pattern

Figure16(b) Principal H plane pattern

The bandwidth (3 dB beam width) can be found to be 90° in the E plane.

RETARDED POTENTIALS:-

To understand the radiation process, a critical look at Maxwell's equations is more than essential. Since for wave propagation all the field quantities have to be time varying, with the presumption of sinusoidal variation, all field quantities involved may be characterized by the term $e^{j\omega t}$. The space variation may be characterized by the term $e^{-\gamma z}$, where γ is the propagation constant which is normally a complex quantity (i.e., $\gamma = \alpha + j\beta$). The parameter α is called the *attenuation constant* and β is called the *phase shift constant*.

As long as waves remain confined to free space, the attenuation can be neglected (i.e., $\alpha = 0$). Thus, the study of radiation may be confined to only those fields which result in waves characterized by the term $e^{-j\beta z}$. The field emanating from an antenna is assumed to be progressing in the positive z direction without attenuation.

BASIC MAXWELL'S EQUATIONS:-

Maxwell's equations can be written in differential and integral forms. For the present study, the differential form of equations is more suited. The relevant equations involving

electric field intensity E , electric flux density D , magnetic field intensity H , magnetic flux density B , current density J and the charge density ρ are as given below.

$$\begin{aligned} \nabla \times H &= J + \partial D / \partial t && \text{(in general),} \\ \nabla \times H &= \partial D / \partial t \text{ (if } J = 0) && \text{and} \quad \nabla \times H = J \text{ (for dc field)} && \dots\dots\dots(1a) \\ \nabla \times E &= -\partial B / \partial t \text{ (in general) and} && \nabla \times E = 0 \text{ (for static field)} && \dots\dots\dots(1b) \\ \nabla \cdot D &= \rho \text{ (in general)} && \text{and} && \nabla \cdot D = 0 \text{ (for charge-free region, i.e., } \rho = 0) && \dots (1c) \\ \nabla \cdot B &= 0 && \dots\dots\dots(1d) \end{aligned}$$

The field quantities involved in (1) are connected by the following relations:

$$\begin{aligned} D &= \epsilon E && \dots\dots\dots(2a) \\ B &= \mu H && \dots (2b) \\ J &= \zeta E = E / \rho && \dots\dots\dots(2c) \end{aligned}$$

In (2), ϵ is the permittivity, μ is the permeability, ζ is the conductivity and ρ is the resistivity ($\rho = 1/\zeta$) of the media. It is to be noted that the symbol ρ involved in (1c) and (2c) represents entirely different quantities.

Besides the above, the other relevant relations are

$$V = \int \frac{\rho dl}{4\pi sR} = \int \frac{\rho_s ds}{4\pi sR} = \int \frac{\rho_v dv}{4\pi sR} \quad 3(a)$$

$$E = -\nabla V \quad 3(b)$$

$$\nabla^2 V = -\rho / \epsilon \text{ (in general)} \quad \text{and} \quad \nabla^2 V = 0 \text{ If } \rho = 0 \quad 3(c)$$

In (3a), V is the scalar electric potential; ρ_l , ρ_s and ρ_v are line, surface and volume charge densities; and R is the distance between the source and the point at which V is to be evaluated.

$$\nabla \cdot A = \int \frac{\mu I dl}{4\pi R} = \int \frac{\mu K ds}{4\pi R} = \int \frac{\mu J dv}{4\pi R} \quad 4(a)$$

$$B = \nabla \times A \quad 4(b)$$

$$\nabla^2 A = -\mu J \text{ (in general)} \quad \text{and} \quad \nabla \cdot A = 0 \quad \text{for } J = 0 \quad (4c)$$

In (4), A is the vector magnetic potential, I is the current, K is the surface current density and J and R are the same as defined earlier.

RETARDED (TIME VARYING) POTENTIALS:-

Since radiation is a time varying phenomena, the validity of these relations needs to be tested. To start with consider (3b) When its curl is taken, it is noted that

$$\nabla \times E = \nabla \times (-\nabla V) \equiv 0 \quad (1)$$

In view of the vector identity that the curl of a gradient is identically zero. But from (1b)

$\nabla \times E = -\partial B / \partial t$ for a time-varying field. The discrepancy is obvious and can be addressed by using (4b)

$$\text{Let } E = -\nabla V + N \quad (2)$$

$$\nabla \times E = \nabla \times (-\nabla V) + \nabla \times N = 0 + \nabla \times N = -\partial B / \partial t = -\partial(\nabla \times A) / \partial t$$

$$\text{Thus, } \nabla \times N = -\partial(\nabla \times A) / \partial t = -\nabla \times (\partial A / \partial t) = \nabla \times (-\partial A / \partial t)$$

$$\text{Or } \nabla \times N = -\partial A / \partial t \quad (3)$$

Substitution of (3) in (2) gives a new relation (4) which satisfies both the static and the time-varying conditions:

$$E = -\nabla V - \partial A / \partial t \quad (4)$$

In the second step, the validity of (1c) is to be tested by using the relation of (2a) and (4).

$$\begin{aligned} \nabla \cdot D &= \nabla \cdot (EE) = E \nabla \cdot E \\ &= E \nabla \cdot (-\nabla V - \partial A / \partial t) \\ &= E(-\nabla \cdot \nabla V - \partial / \partial t (\nabla \cdot A)) = \rho \end{aligned}$$

$$\text{From the above relation, } \nabla^2 V + \partial / \partial t (\nabla \cdot A) = -\rho / E \quad (5)$$

The RHS of (5) leads to the following relations:

$$\nabla^2 V = -\rho / E \text{ for static conditions} \quad (6a)$$

$$\nabla^2 V = -\rho / E - \partial / \partial t (\nabla \cdot A) \quad \text{for time-varying conditions} \quad (6b)$$

In the third step, the validity of (1a) is to be tested by using the relations of equation (2b), (4b) and (4).

$$\nabla \times H = J + \partial D / \partial t \quad (1a)$$

$$B = \mu H \text{ or } H = B / \mu$$

The LHS of (1a) can be written as

$$\text{LHS} = (\nabla \times B) / \mu = (\nabla \times \nabla \times A) / \mu = [\nabla (\nabla \cdot A) - \nabla^2 A] / \mu \quad (7)$$

This relation uses the vector identity $\nabla \times (\nabla \times A) \equiv \nabla(\nabla \cdot A) - \nabla^2 A$ (8)

The RHS of 1(a) can also be written as

$$\begin{aligned} \text{RHS} &= J + E \partial E / \partial t = J + E \partial (-\nabla V - \partial A / \partial t) / \partial t \\ &= J + E [-\nabla (\partial V / \partial t) - \partial^2 A / \partial t^2] \\ &= J - E [\nabla (\partial V / \partial t) + \partial^2 A / \partial t^2] \end{aligned} \quad (9)$$

On equating LHS and RHS terms, one gets

$$\nabla(\nabla \cdot A) - \nabla^2 A = \mu J - \mu E [\nabla (\partial V / \partial t) + \partial^2 A / \partial t^2] \quad (10)$$

In (6b) and (10), the term $\nabla^2 A$ is defined in (4c) in last section, where as the term $\nabla(\nabla \cdot A)$ is yet to be defined. As per the statement of *Helmholtz Theorem*, "A vector field is completely defined only when both its curl and divergence are known". There are some conditions which specify divergence of A . Two of these conditions,

known as **Lorentz gauge condition** and **Coulomb's gauge condition**, are given by (11) and (12) respectively.

$$\nabla \cdot A = -\mu E \partial V / \partial t \quad (11)$$

$$\nabla \cdot A = 0 \quad (12)$$

Using the Lorentz gauge condition, (6b) and (10) can be rewritten as

$$\nabla^2 V = -\rho / \epsilon_0 - \partial (\mu E \partial V / \partial t) / \partial t = -\rho / \epsilon_0 - \mu E (\partial^2 V / \partial t^2) \quad (13)$$

$$\nabla^2 A = -\mu J + \mu E (\partial^2 A / \partial t^2) \quad (14)$$

Radiation for sinusoidal time variation characterized by $e^{j\omega t}$

$$V = V_0 e^{j\omega t} \text{ and } A = A_0 e^{j\omega t}$$

$$\nabla^2 V = -\rho / \epsilon_0 + \omega^2 \mu \epsilon_0 V \quad (15)$$

$$\nabla^2 A = -\mu J + \omega^2 \mu \epsilon_0 A \quad (16)$$

If ρ and J in the expressions of V and A given by (3a) and (4a) of Sec. 4.2, they become functions of time and this time t is replaced by t' such that $t' = t - r/v$. ρ and J can be replaced by $[\rho]$ and $[J]$ respectively.

Equation (3a) and (4a) can now be rewritten as

$$V = \frac{1}{4\pi\epsilon_0} \frac{q}{R} \quad (17)$$

$$A = \frac{\mu [I]}{4\pi R}$$

(18)



Fig. 16 : Geometry of the configuration containing the elemental volume dv and an arbitrary point P .

As an example if $\rho = e^{-r} \cos \omega t$, and t is replaced by t' one gets $[\rho] = e^{-r} \cos[\omega(t - R/v)]$.

In this expression, R is the distance between the elemental volume dv located in a current-carrying conductor and the point P as shown in Fig. 16 and v is the velocity with which the field progresses or the wave travels. V and A given by (17) and (18) are called the **retarded potentials**. If $t' = t + r/v$, V and A are termed as **advanced potentials**. With reference to Fig. 16, equation (17) and (18) can be written as

$$V(r, t) = \frac{1}{4\pi\epsilon_0} \int_V \frac{\rho(r', t)}{R} dv' \quad (19)$$

$$A(r, t) = \frac{\mu_0}{4\pi} \int_V \frac{J(r', t)}{R} dv' \quad (20)$$

In (19) and (20), V and A are the functions of the distance r and the time t . To get the retarded potentials from (19) and (20), t is to be replaced by t' and the resulting field equations are

$$V(r, t) = \frac{1}{4\pi\epsilon_0} \int_V \frac{\rho(r', t - \frac{R}{v})}{R} dv' \quad (21)$$

$$A(r, t) = \frac{\mu_0}{4\pi} \int_V \frac{J(r', t - \frac{R}{v})}{R} dv' \quad (22)$$

Similarly, advanced potential expression can be obtained by replacing $t - R/v$ by $t + R/v$ in (21) and (22).

THIN LINEAR HERTZ ANTENNAS

INTRODUCTION:-

The antennas are symmetrically fed at the center by a balanced two-wire transmission line. The antennas may be of any length, but it is assumed that the current distribution is sinusoidal. Current-distribution measurements indicate that this is a good assumption provided that the antenna is thin, i.e., when the conductor diameter is less than, say, $\lambda/100$. Thus, the sinusoidal current distribution approximates the natural distribution on thin antennas. Examples of the approximate natural-current distributions on a number of thin, linear center-fed antennas of different length are illustrated in fig. 6-7. The currents are in phase over each $\lambda/2$ section and in opposite phase over the next. Referring to fig. 6-8, let us now proceed to develop the far-field equations for a symmetrical, thin, linear, center-fed antenna of length l . The retarded value of the current at any point z on the antenna referred to a point at a distance s is

FIELD COMPONENTS :-

Let us now proceed to find the fields everywhere around a short dipole. Let the dipole of length L be placed coincident with the z axis and with its center at the origin as in Fig. 6-2. The relation of the electric field components, E_r, E_θ and E_ϕ , is then as shown. It is assumed that the medium surrounding the dipole is air or vacuum.

In dealing with antennas or radiating systems, the propagation time is a matter of great importance. Thus, if a current is flowing in the short dipole of Fig. 6-3. The effect of the current is Not felt instantaneously at the point p , but only after an interval Equal to the time required for the disturbance to propagate over The distance r . We have already recognized this in chap. 5 in Connection with the pattern of arrays of point sources, but here We are more explicit and describe it as a *retardation* effect. Accordingly, instead of writing the current i as

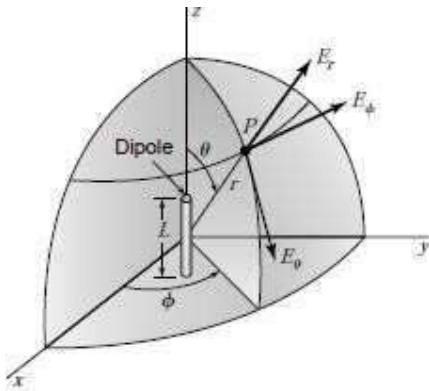

Figure 6-2 Relation of dipole to coordinates.

$$I = I_0 e^{j\omega t} \dots \dots \dots (1)$$

which implies instantaneous propagation of the effect of the current, we introduce the propagation (or retardation) time as done by Lorentz and write

$$[I] = I_0 e^{j\omega[t - (r/c)]} \dots \dots \dots (2)$$

where $[I]$ is called the *retarded current*. Specifically, the retardation time r/c results in a *phase retardation* $\omega r/c = 2\pi f r/c = 360^\circ f r/c = 360^\circ t/T$, where $T = 1/f =$ time of one period or cycle (seconds) and $f =$ frequency (hertz, Hz=cycles per second). The brackets may be added as in (2) to indicate explicitly that the effect of the current is retarded.

Equation (2) is a statement of the fact that the disturbance at a time t and at a distance r from a current element is caused by a current $[I]$ that occurred at an earlier time $t - r/c$. The time difference r/c is the interval required for the disturbance to travel the distance r , where c is the velocity of light ($=300 \text{ Mm s}^{-1}$).

Electric and magnetic fields can be expressed in terms of vector and scalar potentials. Since we will be interested not only in the fields near the dipole but also at distances which are large compared to the wavelength, we must use *retarded potentials*, i.e., expressions involving $t - r/c$. For a dipole located as in Fig. 6-2 or Fig. 6-3a, the retarded vector potential of the electric current has only one component, namely, A_z . Its value is

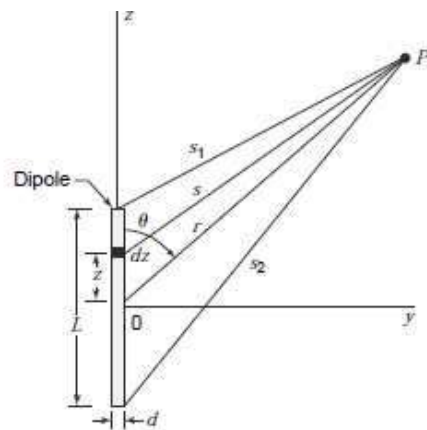

Figure 6-3a Geometry for short dipole.

$$A_z = \frac{\mu_0}{4\pi} \int_{-L/2}^{L/2} \frac{[I]}{s} dz \quad (2)$$

where $[I]$ is the retarded current given by

$$[I] = I_0 e^{j\omega[t-(s/c)]} \quad (3a)$$

In (3) and (3a),

- z = distance to a point on the conductor
- I_0 = peak value in time of current (uniform along dipole)
- μ_0 = permeability of free space = $4\pi \times 10^{-7}$ H m⁻¹

If the distance from the dipole is large compared to its length ($r \gg L$) and if the wavelength is large compared to the length ($\lambda \gg L$), we can put $s = r$ and neglect the phase differences of the field contributions from different parts of the wire. The integrand in (3) can then be regarded as a constant, so that (3) becomes

$$A_z = \frac{\mu_0 L I_0 e^{j\omega[t-(r/c)]}}{4\pi r} \quad (4)$$

The retarded scalar potential V of a charge distribution is

$$V = \frac{1}{4\pi\epsilon_0} \int_V \frac{[\rho]}{s} d\tau \quad (5)$$

where $[\rho]$ is the retarded charge density given by

$$[\rho] = \rho_0 e^{j\omega[t-(s/c)]} \quad (6)$$

In obtaining (12) and (13) the relation was used that $\mu_0 \epsilon_0 = 1/c^2$, where c = velocity of light.

and $d\tau$ = infinitesimal volume element

$$\epsilon_0 = \text{permittivity or dielectric constant of free space} = 8.85 \times 10^{-12} \text{ F m}^{-1}$$

Since the region of charge in the case of the dipole being considered is confined to the points at the ends as in Fig. 6-1b, (5) reduces to

$$V = \frac{1}{4\pi\epsilon_0} \left\{ \frac{[q]}{s_1} - \frac{[q]}{s_2} \right\} \quad (7)$$

From (6-1-1) and (3a),

$$[q] = \int [I] dt = I_0 \int e^{j\omega[t-(s/c)]} dt = \frac{[I]}{j\omega} \quad (8)$$

Substituting (8) into (7),

$$V = \frac{I_0}{4\pi\epsilon_0 j\omega} \left[\frac{e^{j\omega[t-(s_1/c)]}}{s_1} - \frac{e^{j\omega[t-(s_2/c)]}}{s_2} \right] \quad (9)$$

Referring to Fig. 6-3b, when $r \gg L$, the lines connecting the ends of the dipole and the point P may be considered as parallel so that

$$s_1 = r - \frac{L}{2} \cos \theta \quad (10)$$

and

$$s_2 = r + \frac{L}{2} \cos \theta \quad (11)$$

Substituting (10) and (11) into (9), it may be shown that the fields of a short electric dipole are:

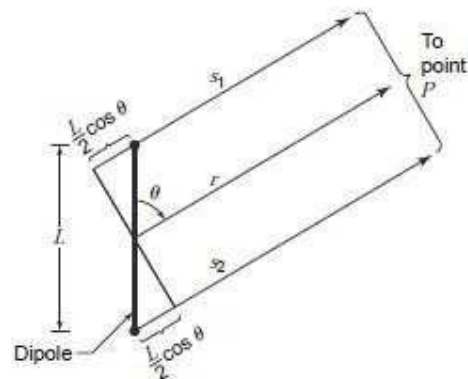

Figure 6-3b Relations for short dipole when $r \gg L$.

$$\text{Electric fields of short dipole} \quad E_r = \frac{I_0 L \cos \theta e^{j\omega[t-(r/c)]}}{2\pi\epsilon_0} \left(\frac{1}{cr^2} + \frac{1}{j\omega r^3} \right) \quad \text{General case} \quad (12)$$

$$\quad \quad \quad E_\theta = \frac{I_0 L \sin \theta e^{j\omega[t-(r/c)]}}{4\pi\epsilon_0} \left(\frac{j\omega}{c^2 r} + \frac{1}{cr^2} + \frac{1}{j\omega r^3} \right) \quad \text{General case} \quad (13)$$

Turning our attention now to the *magnetic field*, this may be calculated from curl of A as follows

$$\nabla \times \mathbf{A} = \frac{\hat{\mathbf{r}}}{r \sin \theta} \left[\frac{\partial(\sin \theta) A_\phi}{\partial \theta} - \frac{\partial(A_\theta)}{\partial \phi} \right] + \frac{\hat{\theta}}{r \sin \theta} \left[\frac{\partial A_r}{\partial \phi} - \frac{\partial(r \sin \theta) A_\phi}{\partial r} \right] + \frac{\hat{\phi}}{r} \left[\frac{\partial(r A_\theta)}{\partial r} - \frac{\partial A_r}{\partial \theta} \right] \quad (14)$$

Since $A_\phi = 0$, the first and fourth terms of (14) are zero, since A_r and A_θ are independent of ϕ , so that the second and third terms of (14) are also zero. Thus, only the last two terms contribute, so that $\mathbf{A} \times \mathbf{A}$, and hence also \mathbf{H} , have only a ϕ component. Thus,

$ \text{Magnetic fields of short dipole} \mathbf{H} = H_\phi = \frac{I_0 L \sin \theta e^{j\omega[t-(r/c)]}}{4\pi} \left(\frac{j\omega}{cr} + \frac{1}{r^2} \right) \quad \text{General case} \quad (15)$	(15)
$H_r = H_\theta = 0$	(16)

Thus, the fields from the dipole have only three components E_r, E_θ and H_ϕ . The components E_ϕ, H_r and H_θ are everywhere zero. When r is very large, the terms in $1/r^2$ and $1/r^3$ in (12), (13), and (15) can be neglected in favor of the terms in $1/r$. Thus, in the *far field* E_r is negligible, and we have effectively only two field components, E_θ and H_ϕ , given by

$\text{Electric and magnetic fields of short dipole} \quad E_\theta = \frac{j\omega I_0 L \sin \theta e^{j\omega[t-(r/c)]}}{4\pi \epsilon_0 c^2 r} = j \frac{I_0 \beta L}{4\pi \epsilon_0 cr} \sin \theta e^{j\omega[t-(r/c)]} \quad \text{Far-field case}$	(17)
$H_\phi = \frac{j\omega I_0 L \sin \theta e^{j\omega[t-(r/c)]}}{4\pi cr} = j \frac{I_0 \beta L}{4\pi r} \sin \theta e^{j\omega[t-(r/c)]}$	(18)

Taking the ratio of E_θ to H_ϕ as given by (17) and (18), we obtain

$\frac{E_\theta}{H_\phi} = \frac{1}{\epsilon_0 c} = \sqrt{\frac{\mu_0}{\epsilon_0}} = 376.7 \Omega \quad \text{Impedance of space}$

This is the *intrinsic impedance of free space* (a pure resistance). It is a very important constant.

Comparing (17) and (18) we note that E_θ and H_ϕ are in time phase in the far field. We note also that the field patterns of both are proportional to $\sin \theta$. The pattern is independent of ϕ , so that the space pattern is doughnut-shaped, being a figure-of-revolution of the pattern in Fig. 6-4a about the axis of the dipole. Referring to the near-field expressions given by (12), (13) and (15), we note that for a small r the electric field has two components E_r and E_θ , which are both in time-phase quadrature with the magnetic field, as in a resonator. At intermediate distances, E_θ and E_r can approach time-phase quadrature so that the total electric field vector rotates in a plane parallel to the direction of propagation, thus exhibiting the phenomenon of *cross-field*. For the E_θ and H_ϕ components, the near-field patterns are the same as the far-field patterns, being proportional to $\sin \theta$ (Fig. 6-4a). However, the near-field pattern for E_r is proportional to $\cos \theta$ as indicated by Fig. 6-4b. The space pattern for E_r is a figure-of-revolution of this pattern around the dipole axis.

Let us now consider the situation at very low frequencies. This will be referred to as the *quasi-stationary*, or dc case. Since from

$$[I] = I_0 e^{j\omega[t-(r/c)]} = j\omega[q] \quad (20)$$

(12) and (13) can be rewritten as

$$E_r = \frac{[q]L \cos \theta}{2\pi \epsilon_0} \left(\frac{j\omega}{cr^2} + \frac{1}{r^3} \right) \quad (21)$$

and

$$E_\theta = \frac{[q]L \sin \theta}{4\pi \epsilon_0} \left(-\frac{\omega^2}{c^2 r} + \frac{j\omega}{cr^2} + \frac{1}{r^3} \right) \quad (22)$$

The magnetic field is given by (15) as

$$H_\phi = \frac{[I]L \sin \theta}{4\pi} \left(\frac{j\omega}{cr} + \frac{1}{r^2} \right) \quad (23)$$

At low frequencies, ω approaches zero so that the terms with ω in the numerator can be neglected. As $\omega \rightarrow 0$, we also have

$$[q] = q_0 e^{j\omega[t-(r/c)]} = q_0 \quad (24)$$

and

$$[I] = I_0 \quad (25)$$

Thus, for the quasi-stationary, or dc, case, the field components become from (21), (22) and (23)

$$E_r = \frac{q_0 L \cos \theta}{2\pi \epsilon_0 r^3} \quad (26)$$

$$\text{Electric and magnetic fields of short dipole } E_\theta = \frac{q_0 L \sin \theta}{4\pi \epsilon_0 r^3} \quad \text{Low-frequency case} \quad (27)$$

$$H_\phi = \frac{I_0 L \sin \theta}{4\pi r^2} \quad (28)$$

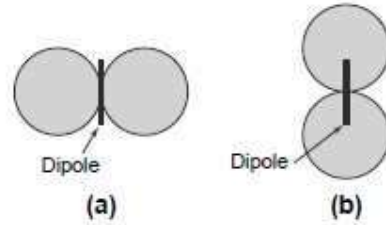

Figure 6-4 Near- and far-field patterns of E_θ and H_ϕ components for short dipole (a) and near-field pattern of E_r component (b).

The restriction that $r \gg L$ still applies. The expressions for the electric field, (26) and (27), are identical to those obtained in electrostatics for the field of two point charges, $+q_0$ and $-q_0$, separated by a distance L .

The relation for the magnetic field, (28), may be recognized as the Biot-Savart relation for the magnetic field of a short element carrying a steady or slowly varying current. Since in the expressions for the quasi-stationary case the fields decrease as $1/r^2$ or $1/r^3$, the fields are confined to the vicinity of the dipole and there is negligible radiation. In the general expressions for the fields, (21), (22) and (23), it is the $1/r$ terms which are important in the far field and hence take into account the radiation. The expressions for the fields from a short dipole developed above are summarized in Table 6-1.

Setting

$$|A| = \frac{1}{2r\lambda}$$

$$|B| = \frac{1}{4\pi r\lambda^2}$$

$$|C| = \frac{1}{8\pi^2 r\lambda^3}$$

Table 6-1 Fields of a short electric dipole[†]

Component	General expression	Far field	Quasi-stationary
E_r	$\frac{[I]L \cos \theta}{2\pi \epsilon_0} \left(\frac{1}{cr^2} + \frac{1}{j\omega r^3} \right)$	0	$\frac{q_0 L \cos \theta}{2\pi \epsilon_0 r^3}$
E_θ	$\frac{[I]L \sin \theta}{4\pi \epsilon_0} \left(\frac{j\omega}{c^2 r} + \frac{1}{cr^2} + \frac{1}{j\omega r^3} \right)$	$\frac{[I]L j\omega \sin \theta}{4\pi \epsilon_0 c^2 r} = \frac{j60\pi [I] \sin \theta L}{r \lambda}$	$\frac{q_0 L \sin \theta}{4\pi \epsilon_0 r^3}$
H_ϕ	$\frac{[I]L \sin \theta}{4\pi} \left(\frac{j\omega}{cr} + \frac{1}{r^2} \right)$	$\frac{[I]L j\omega \sin \theta}{4\pi cr} = \frac{j[I] \sin \theta L}{2r \lambda}$	$\frac{I_0 L \sin \theta}{4\pi r^2}$

[†]The restriction applies that $r \gg L$ and $\lambda \gg L$. The quantities in the table are in SI units, that is, E in volts per meter, H in amperes per meter, I in amperes, r in meters, etc. $[I]$ is as given by (20). Three of the field components of an electric dipole are everywhere zero, that is:

$$E_\phi = H_r = H_\theta = 0$$

For the three components of E_{θ} , their variation with distance is as shown in Fig. 6–5. For $r\lambda$ greater than the Radian distance $[1/(2\pi)]$, component A of the electric field is dominant, for $r\lambda$ less than the radian distance Component C of the electric field is dominant, while at the radian distance only B contributes ($= \pi$) because Although $|A| = |B| = |C| = \pi$, A and C are in phase opposition and cancel.

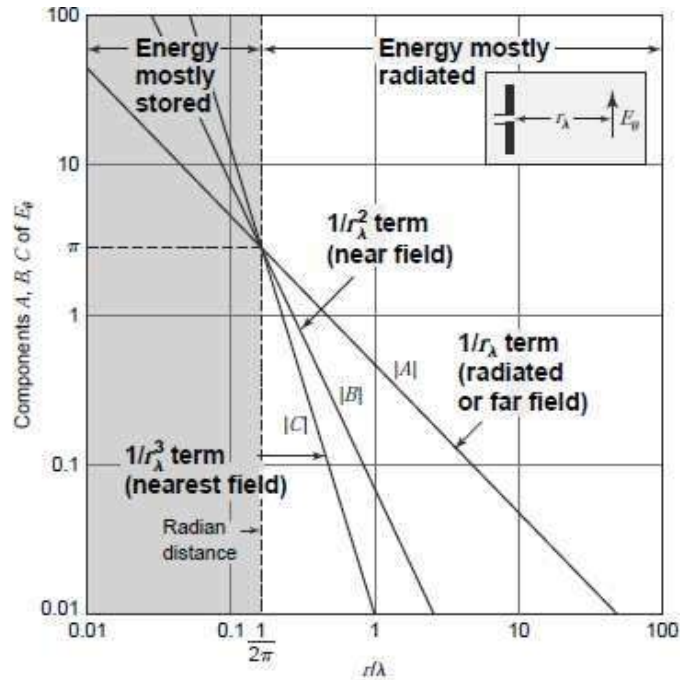

Figure 6–5 Variation of the magnitudes of the components of E_{θ} of a short electric dipole as a function of distance ($r\lambda$). The magnitudes of all components equal π at the radian distance $1/(2\pi)$. At larger distances energy is mostly radiated, at smaller distances mostly stored.

For the special case where $\theta = 90^\circ$ (perpendicular to the dipole in the xy plane of Fig. 6-2) and at $r_\lambda \gg 1/(2\pi)$,

$$|H_\phi| = \frac{I_0 L_\lambda}{2r} \quad (\text{A m}^{-1}) \quad (29)$$

while at $r_\lambda \ll 1/(2\pi)$,

$$|H_\phi| = \frac{I_0 L}{4\pi r^2} \quad (30)$$

which is identical to the relation for the magnetic field perpendicular to a short linear conductor carrying direct current as given by (28).

The magnetic field at any distance r from an infinite linear conductor with direct current is given by

$$H_\phi = \frac{I_0}{2\pi r} \quad (31)$$

which is *Ampere's law*.

Remarkably, the magnitude of the magnetic field in the equatorial plane ($\theta = 90^\circ$) in the far field of an oscillating $\lambda/2$ dipole is identical to (31) (Ampere's law). It is assumed that the current distribution on the $\lambda/2$ dipole is sinusoidal. This is discussed in more detail in Sec. 6-5.

Rearranging the three field components of Table 6-1 for a short electric dipole, we have

$$E_r = \frac{[I]L_\lambda Z \cos \theta}{\lambda} \left[\frac{1}{2\pi r_\lambda^2} - j \frac{1}{4\pi^2 r_\lambda^3} \right] \quad (32)$$

$$E_\theta = \frac{[I]L_\lambda Z \sin \theta}{\lambda} \left[j \frac{1}{2r_\lambda} + \frac{1}{4\pi r_\lambda^2} - j \frac{1}{8\pi^2 r_\lambda^3} \right] \quad (33)$$

$$H_\phi = \frac{[I]L_\lambda \sin \theta}{\lambda} \left[j \frac{1}{2r_\lambda} + \frac{1}{4\pi r_\lambda^2} \right] \quad (34)$$

We note that the constant factor in each of the terms in brackets differs from the factors of adjacent terms by a factor of 2π .

At the radian distance ($r_\lambda = 1/2\pi$) the fields of (32), (33) and (34) reduce to

$$E_r = \frac{2\sqrt{2}\pi [I]L_\lambda Z \cos \theta}{\lambda} \angle -45^\circ \quad (35)$$

$$E_\theta = \frac{\pi [I]L_\lambda Z \sin \theta}{\lambda} \quad (36)$$

$$H_\phi = \frac{\sqrt{2}\pi [I]L_\lambda \sin \theta}{\lambda} \angle 45^\circ \quad (37)$$

The magnitude of the average power flux or Poynting vector in the θ direction is given by

$$S_\theta = \frac{1}{2} \text{Re } E_r H_\phi^* = \frac{1}{2} E_r H_\phi \text{Re } 1 \angle -90^\circ = \frac{1}{2} E_r H_\phi \cos(-90^\circ) = 0 \quad (38)$$

indicating that no power is transmitted. However, the product $E_r H_\phi$ represents imaginary or reactive energy that oscillates back and forth from electric to magnetic energy twice per cycle.

In like manner the magnitude of the power flux or Poynting vector in the r direction is given by

$$S_r = \frac{1}{2} E_\theta H_\phi \cos(-45^\circ) = \frac{1}{2\sqrt{2}} E_\theta H_\phi \quad (39)$$

indicating energy flow in the r direction.

Much closer to the dipole [$r_\lambda \ll 1/(2\pi)$], (32), (33) and (34) reduce approximately to

$$E_r = -j \frac{[I]L_\lambda Z \cos \theta}{4\pi^2 \lambda r_\lambda^3} \quad (40)$$

$$E_\theta = -j \frac{[I]L_\lambda Z \sin \theta}{8\pi^2 \lambda r_\lambda^3} \quad (41)$$

$$H_\phi = \frac{[I]L_\lambda \sin \theta}{4\pi \lambda r_\lambda^2} \quad (42)$$

From these equations it is apparent that $S_r = S_\theta = 0$. However, the products $E_r H_\phi$ and $E_\theta H_\phi$ represent imaginary or reactive energy oscillating back and forth but not going anywhere. Thus, *close to the dipole there is a region of almost complete energy storage.*

Remote from the dipole [$r_\lambda \gg 1/(2\pi)$], (32), (33) and (34) reduce approximately to

$$E_r = 0 \quad (43)$$

$$E_\theta = j \frac{[I]L_\lambda Z \sin \theta}{2\lambda r_\lambda} \quad (44)$$

$$H_\phi = j \frac{[I]L_\lambda \sin \theta}{2\lambda r_\lambda} \quad (45)$$

Since $E_r = 0$, there is no energy flow in the θ direction ($S_\theta = 0$). However, *since $E_\theta H_\phi$ are in time phase, their product represents real power flow in the outward radial direction. This power is radiated.*

Many antennas behave like the dipole with large energy storage close to the antenna.

The region near the dipole is one of stored energy (reactive power) while regions remote from the dipole are ones of radiation. The radian sphere at $r_\lambda = 1/(2\pi)$ marks a zone of transition from one region to the other with a nearly equal division of the imaginary and real (radiated) power.

The region close to the dipole may be likened to a spherical resonator within which pulsating energy is trapped, but with some leakage which is radiated. There is no exact boundary to this resonator region, but if we arbitrarily put it at the radian distance a qualitative picture may be sketched as in Fig. 6-6.

RADIATION RESISTANCE OF SHORT ELECTRIC DIPOLE:-

Let us now calculate the radiation resistance of the short dipole of Fig. 6-1*b*. This may be done as follows. The Poynting vector of the far field is integrated over a large sphere to obtain the total power radiated. This power is then equated to $I^2 R$ where I is the rms current on the dipole and R is a resistance, called the radiation resistance of the dipole.

The *average* Poynting vector is given by

$$S = \frac{1}{2} \text{Re}(E \times H^*) \quad (1)$$

The far-field components are E_θ and H_ϕ so that the radial component of the Poynting vector is

$$S_r = \frac{1}{2} \text{Re} E_\theta H_\phi^* \quad (2)$$

where E_θ and H_ϕ^* are complex.

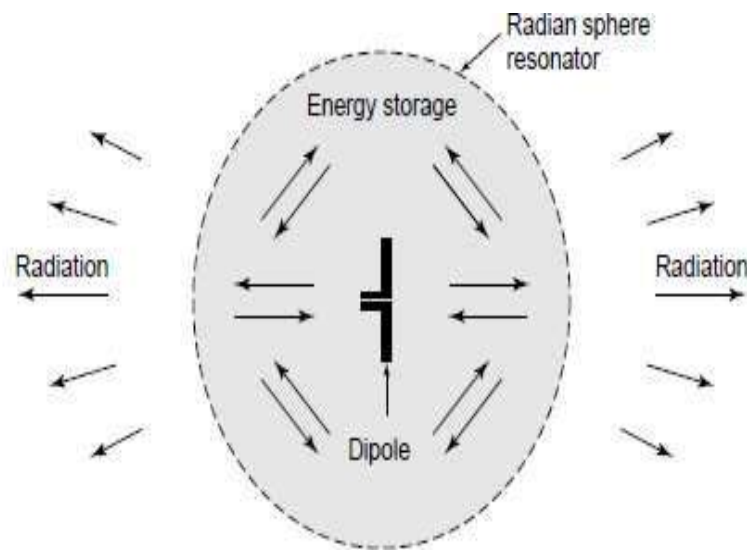

Figure 6-6 Sketch suggesting that within the radiation sphere at $r = \lambda/2\pi = 0.16\lambda$ the situation is like that inside a resonator with high-density pulsating energy accompanied by leakage which is radiated.

The far-field components are related by the intrinsic impedance of the medium. Hence,

$$E_{\theta} = H_{\phi} Z = H_{\phi} \sqrt{\frac{\mu}{\epsilon}} \quad (3)$$

Thus, (2) becomes

$$S_r = \frac{1}{2} \operatorname{Re} Z H_{\phi} H_{\phi}^* = \frac{1}{2} |H_{\phi}|^2 \operatorname{Re} Z = \frac{1}{2} |H_{\phi}|^2 \sqrt{\frac{\mu}{\epsilon}} \quad (4)$$

The total power P radiated is then

$$P = \iint S_r ds = \frac{1}{2} \sqrt{\frac{\mu}{\epsilon}} \int_0^{2\pi} \int_0^{\pi} |H_{\phi}|^2 r^2 \sin \theta d\theta d\phi \quad (5)$$

where the angles are as shown in Fig. 6-2 and $|H_{\phi}|$ is the absolute value of the magnetic field, which from (6-3-18) is

$$|H_{\phi}| = \frac{\omega I_0 L \sin \theta}{4\pi cr} \quad (6)$$

Substituting this into (5), we have

$$P = \frac{1}{32} \sqrt{\frac{\mu}{\epsilon}} \frac{\beta^2 I_0^2 L^2}{\pi^2} \int_0^{2\pi} \int_0^{\pi} \sin^3 \theta d\theta d\phi \quad (7)$$

The double integral equals $8\pi/3$ and (7) becomes

$$P = \sqrt{\frac{\mu}{\epsilon}} \frac{\beta^2 I_0^2 L^2}{12\pi} \quad (8)$$

This is the *average* power or rate at which energy is streaming out of a sphere surrounding the dipole. Hence, it is equal to the power radiated. Assuming no losses, it is also equal to the power delivered to the dipole.

Therefore, P must be equal to the square of the rms current I flowing on the dipole times a resistance R_r , called the *radiation resistance* of the dipole. Thus,

$$\sqrt{\frac{\mu}{\epsilon}} \frac{\beta^2 I_0^2 L^2}{12\pi} = \left(\frac{I_0}{\sqrt{2}}\right)^2 R_r \quad (9)$$

Solving for R_r ,

$$R_r = \sqrt{\frac{\mu}{\epsilon}} \frac{\beta^2 L^2}{6\pi} \quad (10)$$

For air or vacuum $\sqrt{\mu/\epsilon} = \sqrt{\mu_0/\epsilon_0} = 377 = 120\pi \Omega$ so that (10) becomes¹

$\text{Dipole with uniform current} \quad R_r = 80\pi^2 \left(\frac{L}{\lambda}\right)^2 = 80\pi^2 L_{\lambda}^2 = 790 L_{\lambda}^2 \quad (\Omega) \quad \text{Radiation resistance} \quad (11)$

As an example suppose that $L_\lambda = \frac{1}{10}$. Then $R_r = 7.9 \Omega$. If $L_\lambda = 0.01$, then $R_r = 0.08 \Omega$. Thus, the radiation resistance of a short dipole is small.

In developing the field expressions for the short dipole, which were used in obtaining (11), the restriction was made that $\lambda \gg L$. This made it possible to neglect the phase difference of field contributions from different parts of the dipole. If $L_\lambda = \frac{1}{2}$ we violate this assumption, but, as a matter of interest, let us find what the radiation resistance of a $\lambda/2$ dipole is, when calculated in this way. Then for $L_\lambda = \frac{1}{2}$, we obtain $R_r = 197 \Omega$. The correct value is 168Ω (see Prob. 6-6-1), which indicates the magnitude of the error introduced by violating the restriction that $\lambda \gg L$ to the extent of taking $L = \lambda/2$.

It has been assumed that with end loading (see Fig. 6-1a) the dipole current is uniform. However, with no end loading the current must be zero at the ends and, if the dipole is short, the current tapers almost linearly from a maximum at the center to zero at the ends, as in Fig. 2-12, with an average value of $\frac{1}{2}$ of the maximum. Modifying (8) for the general case where the current is not uniform on the dipole, the *radiated power* is

$$P = \sqrt{\frac{\mu}{\epsilon}} \frac{\beta^2 I_{av}^2 L^2}{12\pi} \quad (\text{W}) \quad (12)$$

where I_{av} = amplitude of *average current* on dipole (peak value in time)

The *power delivered* to the dipole is, as before,

$$P = \frac{1}{2} I_0^2 R_r \quad (\text{W}) \quad (13)$$

where I_0 = amplitude of *terminal current* of center-fed dipole (peak value in time). Equating the *power radiated* (12) to the *power delivered* (13) yields, for free space ($\mu = \mu_0$ and $\epsilon = \epsilon_0$), a radiation resistance

$$R_r = 790 \left(\frac{I_{av}}{I_0} \right)^2 L_\lambda^2 \quad (\Omega) \quad (14)$$

For a short dipole without end loading, we have $I_{av} = \frac{1}{2} I_0$, as noted above, and (14) becomes

$$R_r = 197 L_\lambda^2 \quad (\Omega) \quad (15)$$

NATURAL CURRENT DISTRIBUTIONS OF FAR FIELDS AND PATTERNS OF THIN LINEAR CENTER-FED ANTENNAS OF DIFFERENT LENGTHS:-

In this section expressions for the far-field patterns of thin linear antennas will be developed. It is assumed that the antennas are symmetrically fed at the center by a balanced two-wire transmission line. The antennas may be of any length, but it is assumed that the current distribution is sinusoidal. Current-distribution measurements indicate that this is a good assumption provided that the antenna is thin, i.e., when the conductor diameter is less than, say, $\lambda/100$. Thus, the sinusoidal current distribution approximates the natural distribution on thin antennas. Examples of the approximate natural-current distributions on a

number of thin, linear center-fed antennas of different length are illustrated in Fig. 6-7. The currents are in phase over each $\lambda/2$ section and in opposite phase over the next.

Referring to Fig. 6-8, let us now proceed to develop the far-field equations for a symmetrical, thin, linear, center-fed antenna of length L . The retarded value of the current at any point z on the antenna referred to a point at a distance s is

$$[I] = I_0 \sin \left[\frac{2\pi}{\lambda} \left(\frac{L}{2} \pm z \right) \right] e^{j\omega[t - (r/c)]} \quad (1)$$

In (1) the function

$$\sin \left[\frac{2\pi}{\lambda} \left(\frac{L}{2} \pm z \right) \right]$$

is the form factor for the current on the antenna. The expression $(L/2)+z$ is used when $z < 0$ and $(L/2)-z$ is used when $z > 0$. By regarding the antenna as made up of a series of infinitesimal dipoles of length dz , the field of the entire antenna may then be obtained by integrating the fields from all of the dipoles making up the antenna with the result

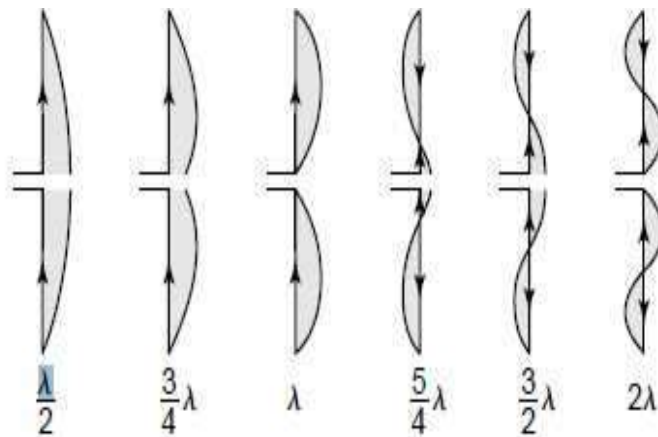

Figure 6-7 Approximate natural-current distribution for thin, linear, center-fed antennas of various lengths.

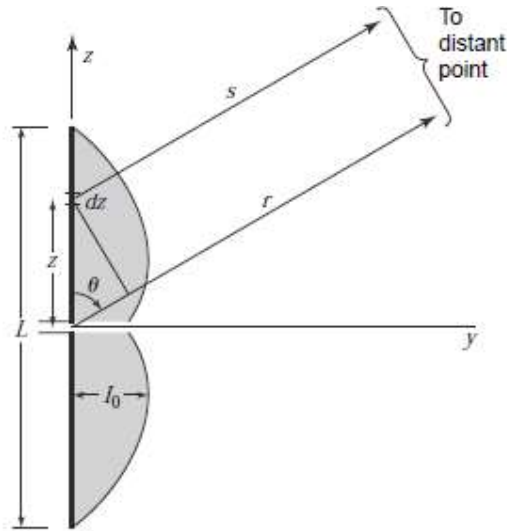

Figure 6-8 Relations for symmetrical, thin, linear, center-fed antenna of length L .

<p style="margin: 0;"><i>Far fields of center-fed dipole</i></p> $H_{\phi} = \frac{j[I_0]}{2\pi r} \left[\frac{\cos[(\beta L \cos \theta)/2] - \cos(\beta L/2)}{\sin \theta} \right]$	(2)
$E_{\theta} = \frac{j60[I_0]}{r} \left[\frac{\cos[(\beta L \cos \theta)/2] - \cos(\beta L/2)}{\sin \theta} \right]$	(3)

where $[I_0] = I_0 e^{j\omega[t - (r/c)]}$ and

$$E_{\theta} = 120\pi H_{\phi} \tag{3a}$$

Equations (2), (3) and (3a) give the far fields H_{ϕ} and E_{θ} of a *symmetrical, center-fed, thin linear antenna of length L* . The shape of the far-field pattern is given by the factor in the brackets. The factors preceding the brackets in (2) and (3) give the instantaneous magnitude of the fields as functions of the antenna current and the distance r . To obtain the rms value of the field, we let $[I_0]$ equal the rms current at the location of the current maximum. There is no factor involving phase in (2) or (3), since the center of the antenna is taken as the phase center. Hence any phase change of the fields as a function of θ will be a jump of 180° when the pattern factor changes sign.

As examples of the far-field patterns of linear center-fed antennas, three antennas of different lengths will be considered. Since the amplitude factor is independent of the length, only the relative field patterns as given by the pattern factor will be compared.

EXAMPLE 6-5.1 $\lambda/2$ Antenna

When $L = \lambda/2$, the pattern factor becomes $E = \cos[(\pi/2) \cos \theta] \sin \theta$

This pattern is shown in Fig. 6-9a. It is only slightly more directional than the pattern of an infinitesimal or short dipole which is given by $\sin \theta$. The beamwidth between half-power points of the $\lambda/2$ antenna is 78° as compared to 90° for the short dipole.

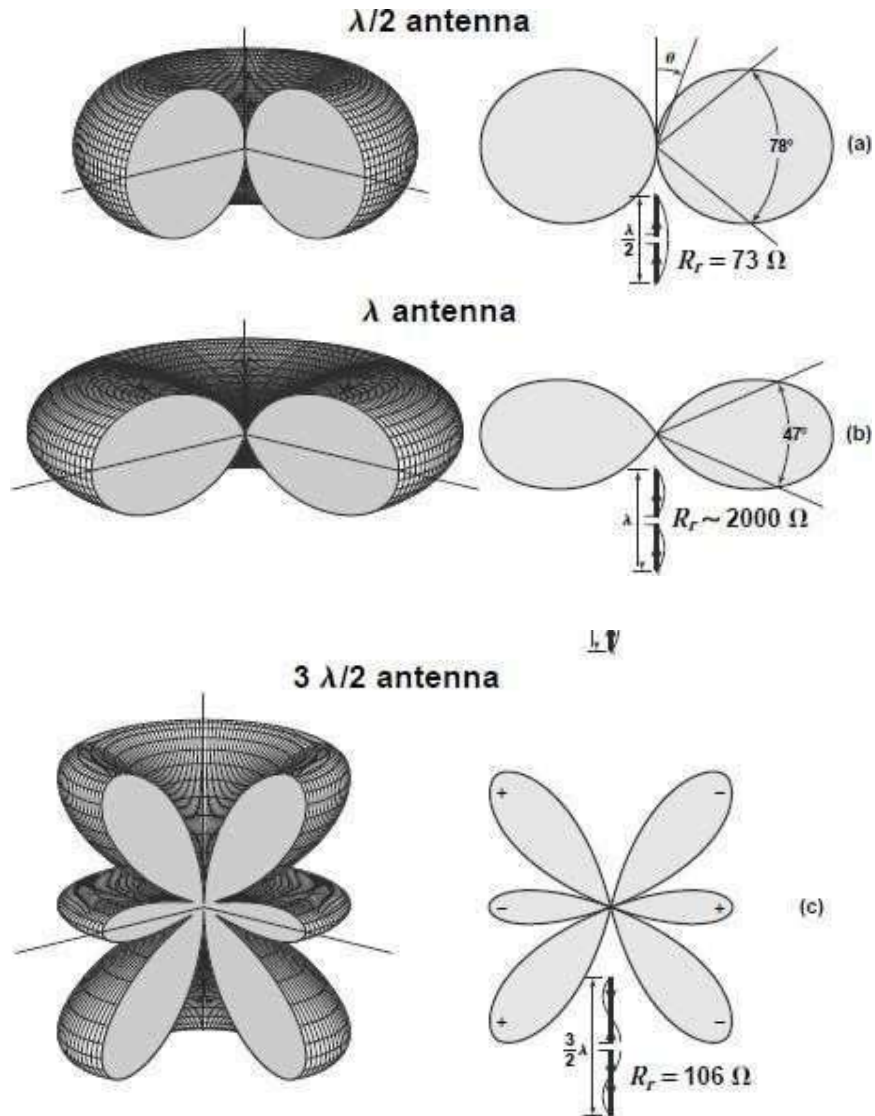

Figure 6-9 Three-dimensional and polar plots of the patterns of $\lambda/2$, λ , and $3\lambda/2$ antennas. The antennas are center-fed with current distributions assumed sinusoidal as indicated.

6-6 Radiation Resistance of $\lambda/2$ Antenna

To find the radiation resistance, the Poynting vector is integrated over a large sphere yielding the power radiated, and this power is then equated to $(I_0/\sqrt{2})^2 R_0$, where R_0 is the radiation resistance at a current maximum point and I_0 is the peak value in time of the current at this point. The total power P radiated was given in (6-4-5)¹ in terms of H_ϕ for a short dipole. In (6-4-5), $|H_\phi|$ is the absolute value. Hence, the corresponding value of H_ϕ for a linear antenna is obtained from (6-5-2) by putting $|j[I_0]| = I_0$. Substituting this into 6-4-5, we obtain

$$P = \frac{15I_0^2}{\pi} \int_0^{2\pi} \int_0^\pi \frac{\{\cos[(\beta L/2) \cos \theta] - \cos(\beta L/2)\}^2}{\sin \theta} d\theta d\phi \quad (1)$$

$$= 30I_0^2 \int_0^\pi \frac{\{\cos[(\beta L/2) \cos \theta] - \cos(\beta L/2)\}^2}{\sin \theta} d\theta \quad (2)$$

Equating the radiated power as given by (2) to $I_0^2 R_0/2$ we have

$$P = \frac{I_0^2 R_0}{2} \quad (3)$$

and

$$R_0 = 60 \int_0^\pi \frac{\{\cos[(\beta L/2) \cos \theta] - \cos(\beta L/2)\}^2}{\sin \theta} d\theta \quad (4)$$

where the radiation resistance R_0 is referred to the current maximum. In the case of a $\lambda/2$ antenna this is at the center of the antenna or at the terminals of the transmission line (see Fig. 6-7).

$$^1 P = \iint S \cdot ds = \frac{1}{2} \sqrt{\mu/\epsilon} \iint |H_\phi|^2 ds$$

Proceeding with the evaluation of (4) with the aid of the sine integral, $\text{Si}(x)$, and the cosine integral, $\text{Cin}(x)$, it may be shown that the radiation resistance of the $\lambda/2$ antenna is

$$R_r = 30 \text{Cin}(2\pi) = 30 \times 2.44 = 73 \Omega \quad (5)$$

This is the well-known value for the radiation resistance of a thin, linear, center-fed, $\lambda/2$ antenna with sinusoidal current distribution. The terminal impedance also includes some inductive reactance as discussed in Chap. 18. That is,

$$Z = 73 + j42.5 \Omega \quad (6)$$

To make the reactance zero, that is, to make the antenna resonant, requires that the antenna be shorted a few percent less than $\lambda/2$. This shortening also results in a reduction in the value of the radiation resistance to about 65 Ω .

POEER RADIATED BY A CURRENT ELEMENT:-

It can be noted that E has no ϕ component and H contains only a ϕ component and thus

$$E = E_r a_r + E_\theta a_\theta \text{ and } H = H_\phi a_\phi \quad (1)$$

The power flow can be given by the Poynting vector P

$$P = E \times H = (E_r a_r + E_\theta a_\theta) \times H_\phi a_\phi = -E_r H_\phi a_\theta + E_\theta H_\phi a_r = P_\theta a_\theta + P_r a_r \quad (2)$$

where $P_\theta = -E_r H_\phi$

$$\begin{aligned} &= -\frac{2I^2 dl^2 \sin \theta \cos \phi}{16\pi^2 \epsilon} \left[-\frac{\omega \sin \omega t' \cos \omega t'}{r^3 v^2} + \frac{\cos^2 \omega t'}{r^4 v} - \frac{\omega \sin^2 \omega t'}{\omega r^4 v} + \frac{\sin \omega t' \cos \omega t'}{\omega r^5} \right] \\ &= \frac{I^2 dl^2 \sin 2\theta}{16\pi^2 \epsilon} \left[-\frac{\cos 2\omega t'}{r^4 v} - \frac{\sin 2\omega t'}{2\omega r^5} + \frac{\omega \sin 2\omega t'}{2r^3 v^2} \right] \end{aligned} \quad (3)$$

As the average power in the terms involving $\sin 2\omega t'$ and $\cos 2\omega t'$ over a complete cycle is zero, P_θ represents the power which surges back and forth in the θ direction and there is no net power flow in the direction of propagation.

$$\begin{aligned} P_r &= E_\theta H_\phi \\ &= \frac{I^2 dl^2 \sin^2 \theta}{16\pi^2 \epsilon} \left[-\frac{\omega^2 \sin^2 \omega t'}{r^2 v^3} + \frac{\omega \cos \omega t' \sin \omega t'}{r^3 v^2} - \frac{\omega \sin^2 \omega t'}{\omega r^4 v} \right. \\ &\quad \left. - \frac{\omega \sin \omega t' \cos \omega t'}{r^3 v^2} + \frac{\cos^2 \omega t'}{r^4 v} + \frac{\sin \omega t' \cos \omega t'}{r^3 \omega} \right] \\ &= \frac{I^2 dl^2 \sin^2 \theta}{16\pi^2 \epsilon} \left[\frac{\cos 2\omega t'}{r^4 v} - \frac{\omega \sin 2\omega t'}{r^3 v^2} + \frac{\sin 2\omega t'}{2\omega r^5} + \frac{\omega(1 - \cos 2\omega t')}{2r^2 v^2} \right] \end{aligned}$$

Since $\sin 2\omega t'$ and $\cos 2\omega t'$ terms will not contribute towards average power, all such terms can be eliminated. In view of the remaining terms

$$P_r = \frac{\omega^2 I^2 dl^2 \sin^2 \theta}{32\pi^2 r^2 v^3 \epsilon} = \frac{1}{2\epsilon v} \left(\frac{\omega I dl \sin \theta}{4\pi r v} \right)^2 = \frac{\eta}{2} \left(\frac{\omega I dl \sin \theta}{4\pi r v} \right)^2 \text{ watts/sq.m} \quad (4)$$

The amplitudes of components contributing towards net power flow are

$$E_{\theta} = \frac{\omega I dl \sin \theta}{4\pi r \epsilon v^2} = \frac{\eta I dl \sin \theta}{2\pi r} = \frac{60\pi I dl \sin \theta}{\lambda r} \quad (5)$$

$$H_{\phi} = \frac{\omega I dl \sin \theta}{4\pi r v} = \frac{I dl \sin \theta}{2\lambda r} \quad (6)$$

$$\frac{E_{\theta}}{H_{\phi}} = 120\pi = \eta_0 \approx 377\Omega \quad (7)$$

Parameter η_0 is called the *characteristic impedance of free space*.

The total radiated power P can be obtained by integrating the average power over the entire surface of an imaginary sphere of radius r .

$$P = \int P_{av} ds \quad \text{where} \quad ds = r d\phi r d\theta \sin \theta = 2\pi r^2 \sin \theta d\theta \quad (8)$$

$$P = \int_0^{\pi} \frac{\eta}{2} \left(\frac{\omega I dl \sin \theta}{4\pi r v} \right)^2 2\pi r^2 \sin \theta d\theta = \frac{\eta \omega^2 I^2 dl^2}{12\pi v^2} \text{ watts} \quad (9)$$

In (9), I represents the peak current. If P is to be obtained in terms of effective current I_{eff} , the total power can be written as

$$P = \frac{\eta \omega^2 I_{eff}^2 dl^2}{6\pi v^2} = \frac{20\omega^2 I_{eff}^2 dl^2}{v^2} \quad (10)$$

On replacing ω by $2\pi f$ and v by the velocity of light c , (10) yields

$$P = 20 \frac{(2\pi f)^2}{c^2} I_{eff}^2 dl^2 = 80\pi^2 \left(\frac{dl}{\lambda} \right)^2 I_{eff}^2 = R_{rad} I_{eff}^2 \quad (11)$$

where R_{rad} is the radiation resistance. In arriving at (9) from (8), the following relation is employed

$$\int_0^{\pi} \sin^3 \theta d\theta = \left[\frac{1}{3} \cos 3\theta - \cos \theta \right]_0^{\pi} = 4/3 \quad (12)$$

From (11), the R_{rad} obtained for three different cases of radiating elements shown in Fig. 4–6 are the following:

Case (a) Radiation resistance for an element of length dl with uniform current distribution shown in Fig. 4–6a is given by

$$R_{rad} = 80\pi^2 (dl/\lambda)^2 \approx 800(dl/\lambda)^2 \Omega \quad (13)$$

Case (b) Radiation resistance for an element of length dl with non-uniform current distribution shown in Fig. 4–6b is given by

$$R_{rad} = 20\pi^2 (dl/\lambda)^2 \approx 200(L/\lambda)^2 \Omega \quad (14)$$

Case (c) Radiation resistance for an element of length $h = 2dl = 2L$ with non-uniform current distribution shown in Fig. 4-6c is given by

$$R_{rad} = 10\pi^2(L/\lambda)^2 = 100(L/\lambda)^2 \approx 400(h/\lambda)^2 \Omega \quad (15)$$

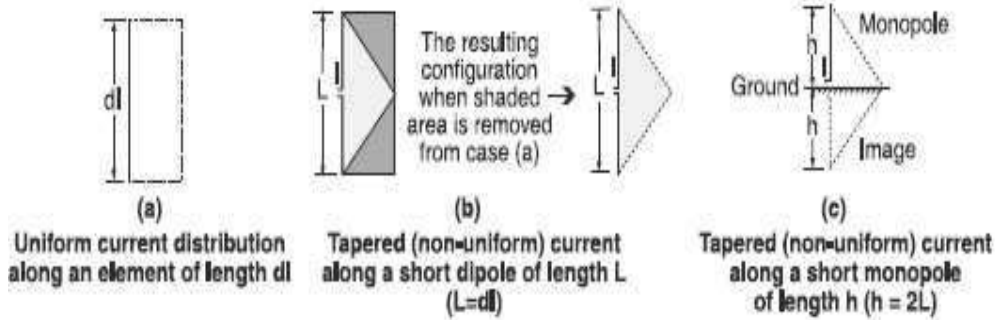

Figure 4-6 Three different cases of radiating elements.

Thnsn rnlations hold good for vnry short antnnnas, that is, up to $\lambda/8$ in lngth.

CURRENT DISTRIBUTIONS OF QUARTER WAVE MONOPOLE AND HALF WAVE DIPOLE:

A half-wave dipole and a quarter-wave monopole are shown. The currents are given as

$$I = im \sin \beta(h - z) \text{ for } z > 0 \text{ and } i = im \sin \beta(h + z) \text{ for } z < 0 \quad (1)$$

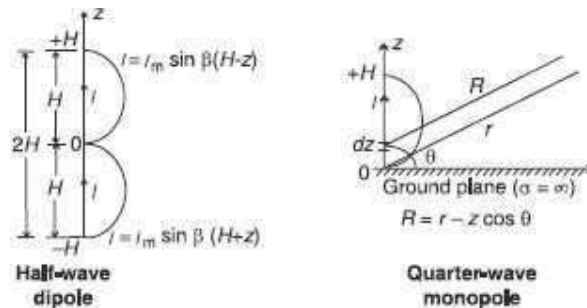

Figure 4-7 Half-wave dipole or quarter-wave monopole with assumed sinusoidal current distribution.

The dipole or monopole is assumed to be located on a perfectly conducting ground. The field is to be obtained at a point which is so distantly located that the distances r and R (shown in the Fig. 4-7) can be considered to bear the following relation.

$$R = r \text{ for the estimation of amplitude and } R = r - z \cos \theta \text{ for the estimation of phase.} \quad (2)$$

Since the current in the dipole is in the z -direction, the z component of the differential vector magnetic potential is

$$dA_z = \frac{\mu I dz}{4\pi R} e^{-j\beta R} \quad (3)$$

$$\begin{aligned} A_z &= \frac{\mu}{4\pi} \int_{-H}^0 \frac{I_m \sin \beta(H+z)}{R} e^{-j\beta R} dz + \frac{\mu}{4\pi} \int_0^H \frac{I_m \sin \beta(H-z)}{R} e^{-j\beta R} dz \\ &= \frac{\mu I_m}{4\pi r} e^{-j\beta r} \left[\int_{-H}^0 \sin \beta(H+z) e^{j\beta z \cos \theta} dz + \int_0^H \sin \beta(H-z) e^{j\beta z \cos \theta} dz \right] \end{aligned} \quad (4)$$

For $H = \lambda/4$, $\beta H = \pi/2$, $\sin \beta(H+z) = \sin \beta(H-z)$ and $\sin(\pi/2 + \beta z) = \sin(\pi/2 - \beta z) = \cos \beta z$

$$\begin{aligned} A_z &= \frac{\mu I_m}{4\pi r} e^{-j\beta r} \int_0^H \cos \beta z (e^{j\beta z \cos \theta} + e^{-j\beta z \cos \theta}) dz \\ &= \frac{\mu I_m}{4\pi r} e^{-j\beta r} 2 \int_0^H \cos \beta z \cos(\beta z \cos \theta) dz \\ &= \frac{\mu I_m}{4\pi r} e^{-j\beta r} 2 \int_0^H [\cos \beta z (1 + \cos \theta) + \cos \beta z (1 - \cos \theta)] dz \\ &= \frac{\mu I_m}{4\pi r} e^{-j\beta r} 2 \left[\frac{\sin \beta z (1 + \cos \theta)}{\beta (1 + \cos \theta)} + \frac{\sin \beta z (1 - \cos \theta)}{\beta (1 - \cos \theta)} \right]_0^{\lambda/4} \\ &= \frac{\mu I_m}{4\pi \beta r} e^{-j\beta r} \left[(1 - \cos \theta) \cos\left(\frac{\pi}{2} \cos \theta\right) + (1 + \cos \theta) \cos\left(\frac{\pi}{2} \cos \theta\right) \right] \frac{1}{\sin^2 \theta} \\ &= \frac{\mu I_m}{2\pi \beta r} e^{-j\beta r} \left[\frac{\cos\{(\pi/2) \cos \theta\}}{\sin^2 \theta} \right] \end{aligned} \quad (5)$$

If $J = J_z$ and $B = \nabla \times A = B_\phi a_\phi$ only, thus $\mu H_\phi = -\frac{\partial A_z}{\partial r} \sin \theta$

$$H_\phi = \frac{j I_m e^{-j\beta r}}{2\pi r} \left[\frac{\cos\{(\pi/2) \cos \theta\}}{\sin \theta} \right] \quad (6)$$

$$E_\theta = \eta H_\phi = 120\pi H_\phi = \frac{j 60 I_m e^{-j\beta r}}{r} \left[\frac{\cos\{(\pi/2) \cos \theta\}}{\sin \theta} \right] \quad (7)$$

The magnitudes of E_θ and H_ϕ are

$$|E_\theta| = \frac{60 I_m}{r} \left[\frac{\cos\{(\pi/2) \cos \theta\}}{\sin \theta} \right] \quad (8)$$

$$|H_\phi| = \frac{I_m}{2\pi r} \left[\frac{\cos\{(\pi/2) \cos \theta\}}{\sin \theta} \right] \quad (9)$$

$$P_{av} = |E_\theta| |H_\phi| = \frac{\eta I_m^2}{8\pi^2 r^2} \left[\frac{\cos^2\{(\pi/2) \cos \theta\}}{\sin^2 \theta} \right] \quad (10)$$

The total radiated power P is given by $\int P_{av} ds$. Thus

$$P = \frac{\eta I_m^2}{4\pi} \int_0^{\pi/2} \left[\frac{\cos^2\{(\pi/2) \cos \theta\}}{\sin^2 \theta} \right] d\theta \quad (11)$$

The evaluation of (11) gives

$$P = \frac{0.609 \eta I_m^2}{4\pi} = \frac{0.609 \eta I_{eff}^2}{2\pi} = 36.5 I_{eff}^2 = I_{eff}^2 R_{rad} \quad (12)$$

where $R_{rad} = 36.5 \text{ } \Omega$ is the radiation resistance of a quarter-wave monopole. The radiation resistance of a half-wave dipole is twice of the above, i.e., $73 \text{ } \Omega$.

RADIATION RESISTANCE:

The radiation resistance of an antenna is defined as the equivalent resistance that would dissipate the same amount of power as is radiated by the antenna. For the elementary current element we have discussed so far. From equation (3.26) we find that radiated power density

$$P_{av} = |I|^2 \eta_0 (dl)^2 K_0^2 \sin^2 \theta / 32 \pi^2 r^2 a_r \quad (1)$$

Radiated power :-

$$P_r = |I|^2 \eta_0 (dl)^2 K_0^2 \sin^2 \theta / 32 \pi^2 r^2 \int_{\theta=0}^{\pi} \int_{\phi=0}^{2\pi} \sin^2 \theta r^2 \sin \theta d\theta d\phi$$

$$= |I|^2 \eta_0 (dl)^2 K_0^2 \sin^2 \theta / 32 \pi^2 \int_{\phi=0}^{2\pi} d\phi \int_{\theta=0}^{\pi} \sin^3 \theta d\theta \dots (2)$$

Where $\int_{\theta=0}^{\pi} \sin^3 \theta d\theta = 2$ but here we have $\int_{\theta=0}^{\pi} \sin^3 \theta d\theta = 2 \times \int_{\theta=0}^{\pi/2} \sin^3 \theta d\theta = 2 \times 2/3$

$$P_r = |I|^2 \eta_0 (dl)^2 K_0^2 / 12 \pi \dots (3)$$

Further $dP_r = P_{av} r^2 \sin \theta d\theta d\phi a_r = P_{av} a_r r^2 d\Omega$

$$dP_r / d\check{A} = |I|^2 \eta_0 (dl)^2 K_0^2 \sin^2\theta / 32 \pi^2 \dots\dots\dots (4)$$

From (3) and (4)

$$D(\theta, \check{\phi}) = 1.5 \sin^2\theta$$

Directivity $D = D(\theta, \check{\phi})|_{\max}$ which occurs at $\theta = \pi/2$. If R_r is the radiation resistance of the

elementary dipole antenna, then

$$\frac{1}{2} |I|^2 R_r = P_r$$

Substituting P_r from eq(3) we get

$$R_r = \eta_0 / 6\pi (2\pi \frac{dl}{\lambda_0})^2 \dots\dots\dots (5)$$

Substituting η_0 as 120π

$$R_r = 480\pi^3 / 6\pi (\frac{dl}{\lambda_0})^2 \dots\dots\dots (6)$$

$$R_r = 480\pi^2 / 6\pi (\frac{dl}{\lambda_0})^2 \dots\dots\dots (7)$$

For such an elementary dipole antenna the principal E and H plane pattern are shown in Fig 16(a) and (b).

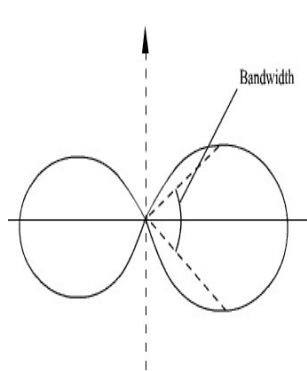

Figure16 (a) Principal E plane pattern

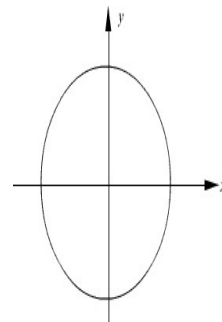

Figure16(b) Principal H plane pattern

The bandwidth (3 dB beam width) can be found to be 90° in the E plane.

EFFECTIVE AREA OF AN ANTENNA:-

An antenna operating as a receiving antenna extracts power from an incident electromagnetic wave. The incident wave on a receiving antenna may be assumed to be a uniform plane wave being intercepted by the antenna. This is illustrated in Fig 3.5. The incident electric field sets up currents in the antenna and delivers power to any load connected to the antenna. The induced current also re-radiates fields known as scattered field. The total electric field outside the antenna will be sum of the incident and scattered fields and for perfectly conducting antenna the total tangential electric field component must vanish on the antenna surface.

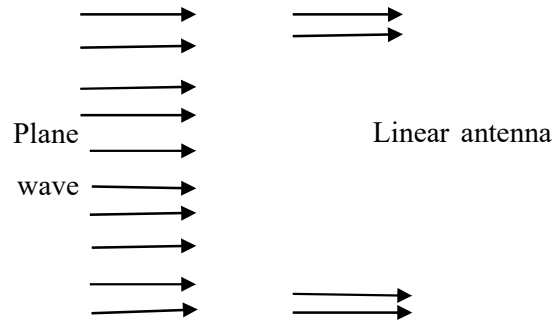

Fig. 1. Plane wave intercepted by an antenna

Let P_{inc} represents the power density of the incident wave at the location of the receiving antenna and P_L represents the maximum average power delivered to the load under matched conditions with the receiving antenna properly oriented with respect to the polarization of the incident wave.

We can write,

$$P_L = A_{ea} P_{inc} \dots\dots\dots (9)$$

Where $P_{inc} = E^2/2 \eta_0$ and the term A_{ea} is called the maximum effective aperture of the antenna. A_{ea} is related to the directivity of the antenna D as,

$$D = \frac{4}{\lambda^2} A_{ea} \dots\dots\dots (10)$$

If the antenna is lossy then some amount of the power intercepted by the antenna will be dissipated in the antenna.

From eqn. (2) we find that

$$G = \eta D \dots\dots\dots(11)$$

Therefore, from (5),

$$G = \frac{4}{\lambda^2} (\eta A_e) = 4\pi/\lambda^2 A_e \dots\dots\dots (12)$$

Where A_e is called the effective aperture of the antenna (in m^2).

So effective area or aperture A_e of an antenna is defined as that equivalent area which when intercepted by the incident power density P_{in} gives the same amount of received power P_R which is available at the antenna output terminals.

If the antenna has a physical aperture A then aperture efficiency $\eta_e = A_e / A$

EFFECTIVE LENGTH/HEIGHT OF THE ANTENNA:-

When a receiving antenna intercepts incident electromagnetic waves, a voltage is induced across the antenna terminals. The effective length h_e of a receiving antenna is defined as the ratio of the open circuit terminal voltage to the incident electric field strength in the direction of antennas polarization.

$$h_e = \frac{V_{oc}}{E} \dots\dots\dots(13)$$

where V_{oc} = open circuit voltage

E = electric field strength

Effective length h_e is also referred to as effective height.

4. **Effective Length of Antenna (L_{eff})** It is used to indicate the effectiveness of the Antenna as a radiator or receiver of EM energy.
 L_{eff} of Transmitting Antenna It is equal to the length of an equivalent linear antenna which radiates the same field strength as the actual antenna and the current is constant throughout the length of the linear antenna.

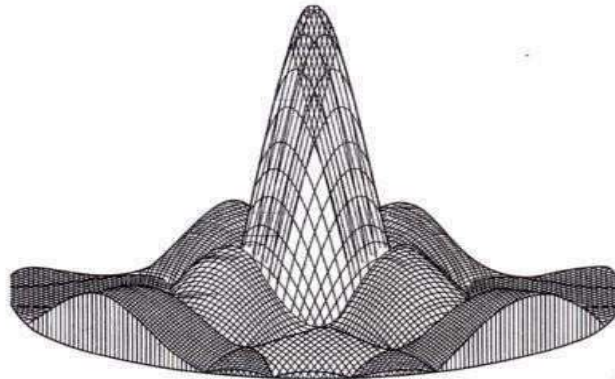

Figure 3.2 (b) Typical 3-D radiation pattern

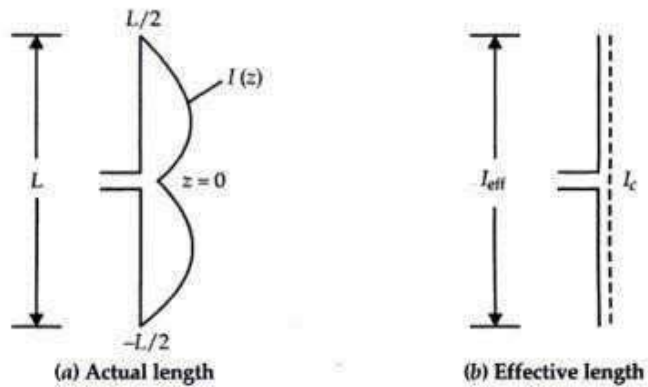

Figure 3.3 Definition of effective length of transmitting antenna

L_{eff} of transmitting antenna is defined mathematically as

$$L_{\text{eff}} (\text{Tx}) = \frac{1}{I_c} \int_{-L/2}^{L/2} I(z) dz \text{ (m)}$$

L_{eff} of receiving antenna It is defined as the ratio of the open circuit voltage developed at the terminals of the antenna under the received field strength, E . That is

$$L_{\text{eff}} (Rx) \equiv \frac{V_{\text{OC}}}{E} \text{ (m)}$$

Effective length of an antenna is always less than the actual length. That is, $L_{\text{eff}} < L$.

5. **Radiation Intensity (RI)** It is defined as the power radiated in a given direction per unit solid angle. That is,

$$RI = r^2 P = \frac{r^2 E^2}{\eta_0} \text{ watts/unit solid angle}$$

Here

- η_0 = intrinsic impedance of the medium (Ω)
- r = radius of the sphere, (m)
- P = power radiated-instantaneous
- E = electric field strength, (V/m)
- $RI = RI(\theta, \phi)$ is a function of θ and ϕ

The unit of a solid angle is Steradian (sr).

RADIAN AND STERADIAN:

Radian is plane angle with its vertex at the centre of a circle of radius r and is subtended by an arc whose length is equal to r . Circumference of the circle is $2\pi r$. Therefore total angle of the circle is 2π radians.

Steradian is solid angle with its vertex at the centre of a sphere of radius r , which is subtended by a spherical surface area equal to the area of a square with side length r . Area of the sphere is $4\pi r^2$. Therefore the total solid angle of the sphere is 4π steradians

A few conversions :

$$1 \text{ radian} = 180/\pi \text{ Degrees}$$

$$1 \text{ radian}^2 = (180/\pi)^2 \text{ degrees}^2 = 3282 \text{ steradians.}$$

$$\text{Square degrees} = 3282 \text{ steradians}$$

ANTENNA BANDWIDTH :- Note that the system is designed for specific frequency; i.e. at any other frequency it will not be one-half wavelength. The *bandwidth* of an antenna is the range of frequencies over which the antenna gives reasonable performance. One definition of reasonable performance is that the standing wave ratio is 2:1 or less at the bounds of the range of frequencies over which the antenna is to be used.

Actually the performance of antenna depends on various characteristics such as antenna gain, side lobe level, SWR, antenna impedance, radiation patterns, antenna polarization, FBR etc., During the operation of antenna these requirements may change and thus there is no unique definition for antenna band width.

ΔW can be specified in many ways.

- (1) Bandwidth over which the gain of the antenna is higher than the acceptable value.
- (2) Bandwidth over which the SWR of transmission line feeding antenna is below acceptable value.
- (3) Bandwidth over which the FBR is minimum equal to the specified value.

Hence BW of antenna can be defined as the band of frequencies over which the antenna maintains required characteristics to the specified value. Antenna BW mainly depends on impedance and pattern of antenna. BW of the antenna is inversely proportional to Q factor of antenna.

$$BW = \Delta W = W_2 - W_1 = W_0/Q$$

$$\Delta f = f_2 - f_1 = f_0/Q \text{ Hz}$$

Where f_0 = centre frequency./design frequency/resonant frequency

$$\text{And quality factor } Q = 2\pi \times \frac{\text{total energy stored by antenna}}{\text{energy radiated per cycle}}$$

ANTENNA BEAM WIDTH:- Antenna beam width is the measure of the directivity of the antenna. It is an angular width in degrees and is measured on a radiation pattern or major lobe. The antenna beam width is defined as the angular width in degrees between the two points on a major lobe of a radiation pattern where the radiated power reduces to the half of the max. value.

The following figure shows how antenna beam width can be measured

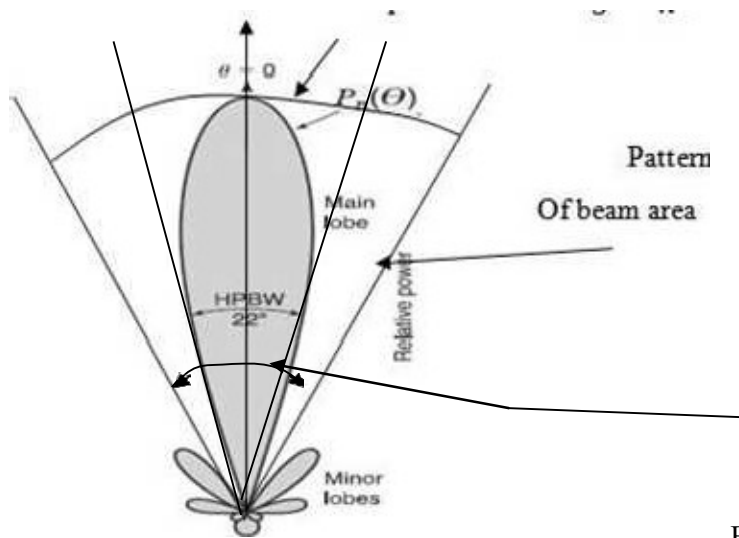

Beam width between first

nulls

Phase Patterns

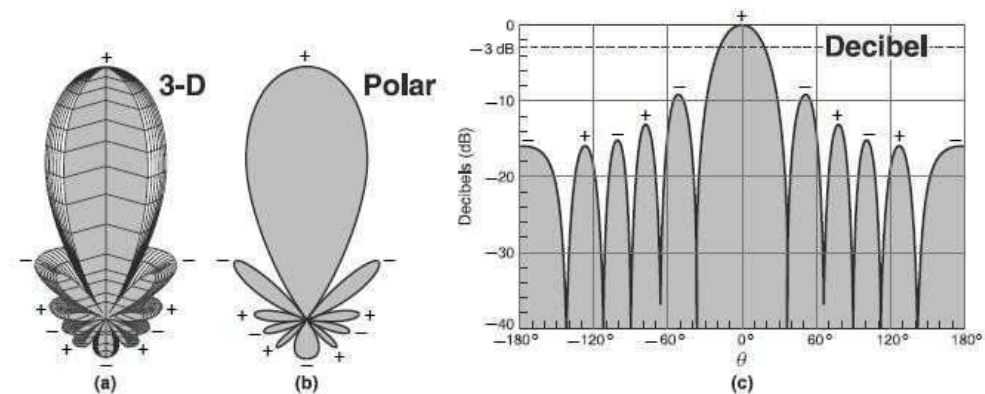

Figure 5-13 Three-dimensional field pattern at (a), polar pattern at (b), and decibel pattern at (c) showing alternate phasing (+ and -) of pattern lobes.

The beam width is also called Half Power beam width (HPBW) because it is measured between two points on the major lobe where the power is half of its max. power.

The directivity (D) of the antenna is related with beam solid angle Ω_A or beam area by,

$$D = \frac{4\pi}{\Omega_A} ; \text{ where } \Omega_A \text{ beam area}$$

$$\Omega_A \approx (\text{HPBW}) \text{ in horizontal plane } \times (\text{HPBW}) \text{ in vertical plane}$$

$$\approx (\text{HPBW}) \text{ in E-plane } \times (\text{HPBW}) \text{ in H- plane}$$

$$B = \Omega_A = \theta_E \times \theta_H$$

$$D = \frac{4\pi}{\theta_E \theta_H} ; \theta_E \text{ \& } \theta_H \text{ are in radians}$$

$$1 \text{ rad} = 180^\circ/\pi \approx 57.3^\circ$$

$$\text{There fore } D = \frac{4\pi}{\theta_E \theta_H} (57.3) = 4125.7 / \theta_E \times \theta_H$$

This formula is applicable to antennas with narrow beam width (about 20°) with no minor lobes in radiation pattern.

The beam width of the antenna is affected by the shape of radiation pattern and width and Length of the dimensions.

ILLUSTRATIVE PROBLEMS:-

Prob 1:

A radiating element of 1cm carries an effective current of 0.5 amp at 3 GHz.

Calculate the radiated power.

Sol:

$$P = \frac{20\omega^2 I_{eff}^2 dl^2}{v^2} = \frac{20 \times (2\pi \times 3 \times 10^9)^2 \times (0.5)^2 \times (10^{-2})^2}{(3 \times 10^8)^2} = 1.1 \text{ mW}$$

Prob 2:- Evaluate the radiation resistance of a radiating element having length $L = 5 \text{ m}$ at

(a) $f = 30 \text{ kHz}$ (b) $f = 30 \text{ MHz}$ (c) $f = 15 \text{ MHz}$.

Sol:

- (a) At $f = 30 \text{ kHz}$, $\lambda = 10^4 \text{ m}$ and $\lambda/10 = 10^3$, thus $L \ll \lambda/10$
Equation (13) is the appropriate equation for this case.
 $R_{rad} \approx 800(dl/\lambda)^2 = 800(5/10^4)^2 = 20 \text{ milli-ohms}$
- (b) At $f = 30 \text{ MHz}$, $\lambda = 10 \text{ m}$ and $L = \lambda/2$
Equation (14) is the appropriate equation for this case.
 $R_{rad} \approx 200(L/\lambda)^2 = 200(1/2)^2 = 50 \text{ ohms}$
- (c) At $f = 15 \text{ MHz}$, $\lambda = 20 \text{ m}$ and $L = \lambda/4$
Equation (15) is the appropriate equation for this case.
 $R_{rad} \approx 400(h/\lambda)^2 = 400(1/4)^2 = 25 \text{ ohms}$

Prob3: The radiating element shown in Fig. 4-2 is of 10 m length and carries a current of 1 amp. It radiates in $\theta = 30^\circ$ direction in free space at $f = 3$ MHz. Estimate the magnitudes of E and H at a point located at 100 km from the point of origination.

Solution

At 3 MHz, $\lambda = 100$ m. As long as the length of the element remains less than or equal to $\lambda/10$, the general expressions of field components given by (10a), (10b) and (11) can be used to estimate the required values. These equations are

$$|H| = \frac{Idl \sin \theta}{4\pi} = \frac{10 \times 0.5}{4\pi} = 1.25/\pi$$

$$|H| = \frac{Idl \sin \theta}{4\pi} = \frac{10 \times 0.5}{4\pi} = 1.25/\pi$$

$$E_r = \frac{2Idl \cos \theta}{4\pi\epsilon} \left[\frac{\cos \omega t'}{r^2 v} + \frac{\sin \omega t'}{\omega r^3} \right] \quad (10a)$$

$$E_\theta = \frac{Idl \sin \theta}{4\pi\epsilon} \left[\frac{-\omega \sin \omega t'}{r v^2} + \frac{\cos \omega t'}{r^2 v} + \frac{\sin \omega t'}{\omega r^3} \right] \quad (10b)$$

$$H_\phi = \frac{Idl \sin \theta}{4\pi} \left[\frac{\cos \omega t'}{r^2} - \frac{\omega \sin \omega t'}{r v} \right] \quad (11)$$

Since only those field components which are inversely proportional to r contribute towards the radiation field, the relevant expressions can be rewritten as

$$E_\theta = \frac{Idl \sin \theta}{4\pi\epsilon} \left[\frac{-\omega \sin \omega t'}{r v^2} \right]$$

$$H_\phi = \frac{Idl \sin \theta}{4\pi} \left[\frac{-\omega \sin \omega t'}{r v} \right]$$

Thus $E = E_\theta a_\theta$ and $H = H_\phi a_\phi$

As can be noticed, E_r does not contain a term which is inversely proportional to r and therefore does not contribute towards radiation field. The magnitudes of the remaining two terms can be written as below.

$$|E_\theta| = \frac{Idl \sin \theta}{4\pi\epsilon} = |E| \quad \text{and} \quad |H_\phi| = \frac{Idl \sin \theta}{4\pi} = |H|$$

The given parameters are

$$\theta = 30^\circ, \text{ thus, } \sin \theta = 0.5, \cos \theta = 0.866, \epsilon = \epsilon_0 = 10^{-9}/36\pi = 8.854 \times 10^{-12}$$

$$Idl = 10 \text{ A-m, } r = 100 \text{ km} = 10^5 \text{ m}$$

Substitution of these values gives

$$|E| = \frac{Idl \sin \theta}{4\pi\epsilon} = \frac{10 \times 0.5}{4\pi \times 10^{-9}/36\pi} = \frac{45}{10^{-9}} = 45 \times 10^9$$

$$P_{av} = \frac{\eta I_m^2}{8\pi^2 r^2} \left[\frac{\cos^2\{(\pi/2) \cos \theta\}}{\sin^2 \theta} \right] = \frac{120\pi \times (5)^2}{8\pi^2 \times (10^3)^2} \left[\frac{\{\cos(\frac{\pi}{2} \cos 60)\}^2}{(\sin 60)^2} \right] = 79.577 \mu\text{W}$$

UNIT II

Yagi uda array

Yagi-Uda or Yagi is named after the inventors Prof. S.Uda and Prof. H.Yagi around 1928.

The basic element used in a Yagi is $\lambda/2$ dipole placed horizontally known as driven element or active element. In order to convert bidirectional dipole into unidirectional system, the passive elements are used which include reflector and director. The passive or parasitic elements are placed parallel to driven element, collinearly placed close together. The Parasitic element placed in front of driven element is called director whose length is 5% less than the drive element. The element placed at the back of driven element is called reflector whose length is 5% more than that of driver element. The space between the element ranges between 0.1λ to 0.3λ .

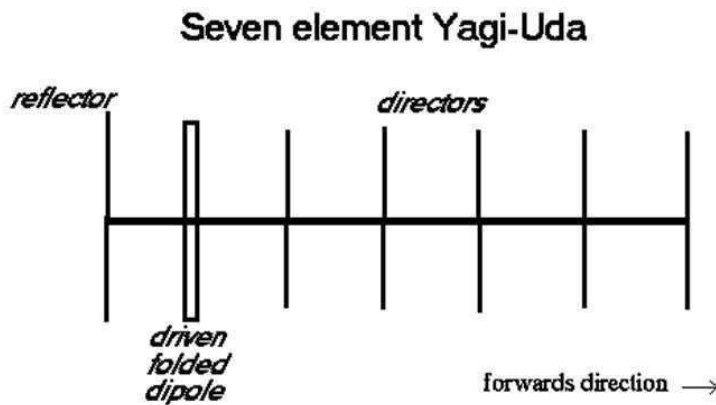

For a three element system,

$$\text{Reflector length} = 500/f \text{ (MHz) feet}$$

$$\text{Driven element length} = 475/f \text{ (MHz) feet}$$

$$\text{Director length} = 455/f \text{ (MHz) feet.}$$

The above relations are given for elements with length to diameter ratio between 200 to 400 and spacing between 0.1λ to 0.2λ . With parasitic elements the impedance reduces less than 73 and may be even less than 25. A folded $\lambda/2$ dipole is used to increase the impedance. System may be constructed with more than one director. Addition of each director increases the gain by nearly 3 dB. Number of elements in a yagi is limited to 11.

Basic Operation:

The phases of the current in the parasitic element depends upon the length and the distance between the elements. Parasitic antenna in the vicinity of radiating antenna is used either to reflect or to direct the radiated energy so that a compact directional system is obtained.

A parasitic element of length greater than $\lambda/2$ is inductive which lags and of length less than $\lambda/2$ is capacitive which leads the current due to induced voltage. Properly spaced elements of length less than $\lambda/2$ act as director and add the fields of driven element. Each director will excite the next. The reflector adds the fields of driven element in the direction from reflector towards the driven element.

The greater the distance between driven and director elements, the greater the capacitive reactance needed to provide correct phasing of parasitic elements. Hence the length of element is tapered-off to achieve reactance.

A Yagi system has the following characteristics.

1. The three element array (reflector, active and director) is generally referred as —beam antenna.
2. It has unidirectional beam of moderate directivity with light weight, low cost and simplicity in design.
3. The band width increases between 2% when the space between elements ranges between 0.1λ to 0.15λ .
4. It provides a gain of 8 dB and a front-to-back ratio of 20dB.
5. Yagi is also known as super-directive or super gain antenna since the system results a high gain.
6. If greater directivity is to be obtained, more directors are used. Array up to 40 elements can be used.
7. Arrays can be stacked to increase the directivity.
8. Yagi is essentially a fixed frequency device. Frequency sensitivity and bandwidth of about 3% is achievable.
9. To increase the directivity Yagi's can be staked one above the other or one by side of the other.

Lens antenna

Like parabolic reflectors, lens is used to convert circular or spherical wave fronts into planar wave fronts, as a transmitter and vice-versa as a receiver. Lens is a medium through which the waves are transmitted or received.

Lenses are of two types like decelerating medium and accelerating medium. In decelerating system, the velocity with in the medium is less than that of free space velocity. Pure dielectrics like Lucite or polystyrene, impure dielectrics or H-plane metal plates can be used as decelerating mediums.

Accelerating system is the one in which the velocity within the medium is more than that of free space velocity. E -plane metal plates are the examples for accelerating types.

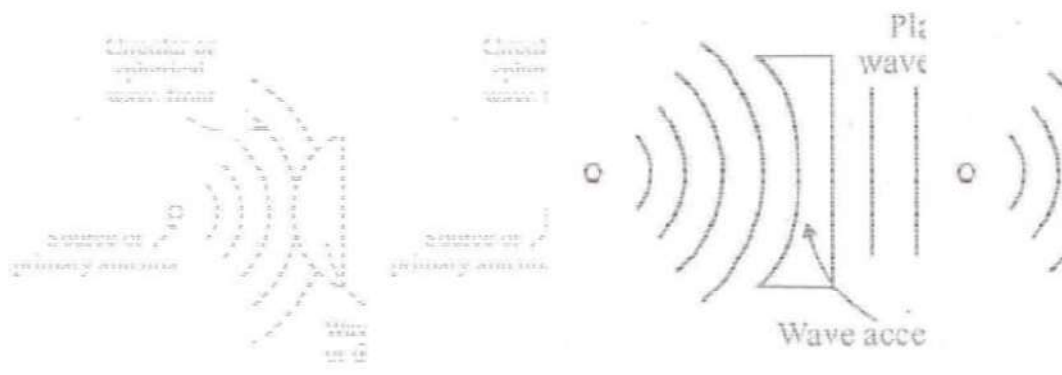
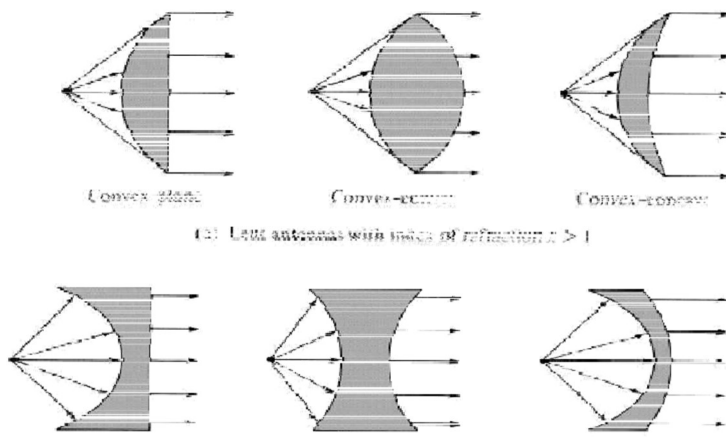

Fig 6.12: Lens Antenna



(a) Lens antennas with index of refraction $n > 1$

(b) Lens antennas with index of refraction $n < 1$

Fig 6.13 : Lens Antenna with different refractive index

Dielectric Lens Antenna

The dielectric material used should have a refractive index more than 1 w.r.t. free space having minimum dielectric losses. Lucite and polystyrene can be used having a refractive index $n=1.5$. The system is constructed in the form of plane-convex lens. The source or primary antenna is placed at the focus point O having focal length L .

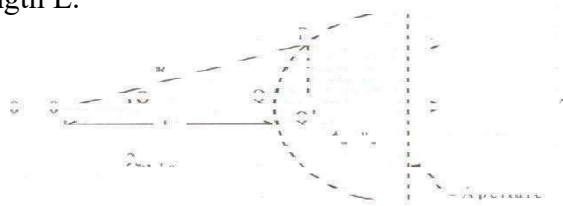

Fig 6.14: Dielectric Lens Antenna

Planar wave fronts can be obtained at the aperture when the electrical path OQ' and OP remains same $OP \ OQ \ OQ'$

Consider the dielectric lens with a primary source at the focus point O as shown in fig.6.15. Let P is the power density and U is radiation intensity at a distance y from the axis. Assuming P and U remain constant within the elemental aperture subtended by $d\theta$ or dy , the power radiated through elemental aperture is

$$dW = 2\pi y \cdot dy \cdot P \dots\dots\dots 6.30$$

Where

$$W = \iint U \cdot d\Omega$$

$$2\pi \theta d\theta$$

$$W = \iint U \sin\theta d\theta d\phi$$

$$2\theta$$

$$\theta d\theta$$

$$W = U 2\pi \int \sin\theta d\theta$$

$$\theta$$

$$W = 2\pi U \sin\theta d\theta$$

$$\dots\dots (6.31)$$

Relative electric field:

Relative Electric field is as shown in fig.6.16

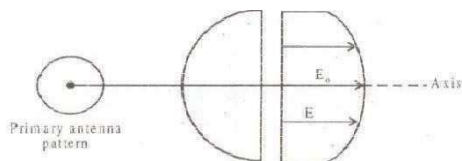

Fig 6.16 : Relative Electric Field

Plane Metal Plate Lens

The velocity in between E-Plane Metal Plate is more than the Free space velocity v_0

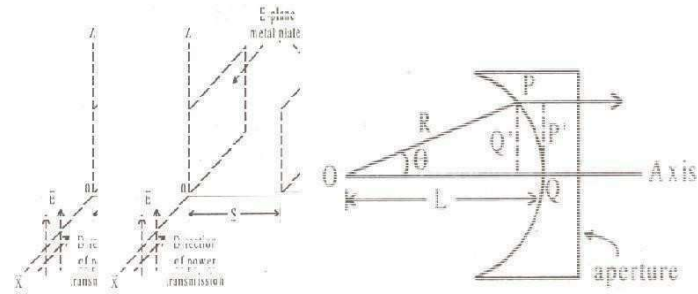

Fig 6.17 : E-Plane Metal Plate Lens

Advantages of Lens Antenna

1. Can be used as Wide band Antenna since its shape is independent of frequency.
2. Provides good collimation.
3. Internal dissipation losses are low, with dielectric materials having low loss tangent.
4. Easily accommodate large band width required by high data rate systems.
5. Quite in-expensive and have good fabrication tolerance

Disadvantages of Lens Antenna

1. Bulky and Heavy
2. Complicated Design
3. Refraction at the boundaries of the lens

Helical Antenna

Helical Antenna consists of a conducting wire wound in the form of a screw thread forming a helix. In the most cases the helix is used with a ground plane. The helix is usually connected to the center conductor of a co-axial transmission line and the outer conductor of the line is attached to the ground plane. Helical antenna is useful at very high frequency and ultra high frequencies to provide circular polarization.

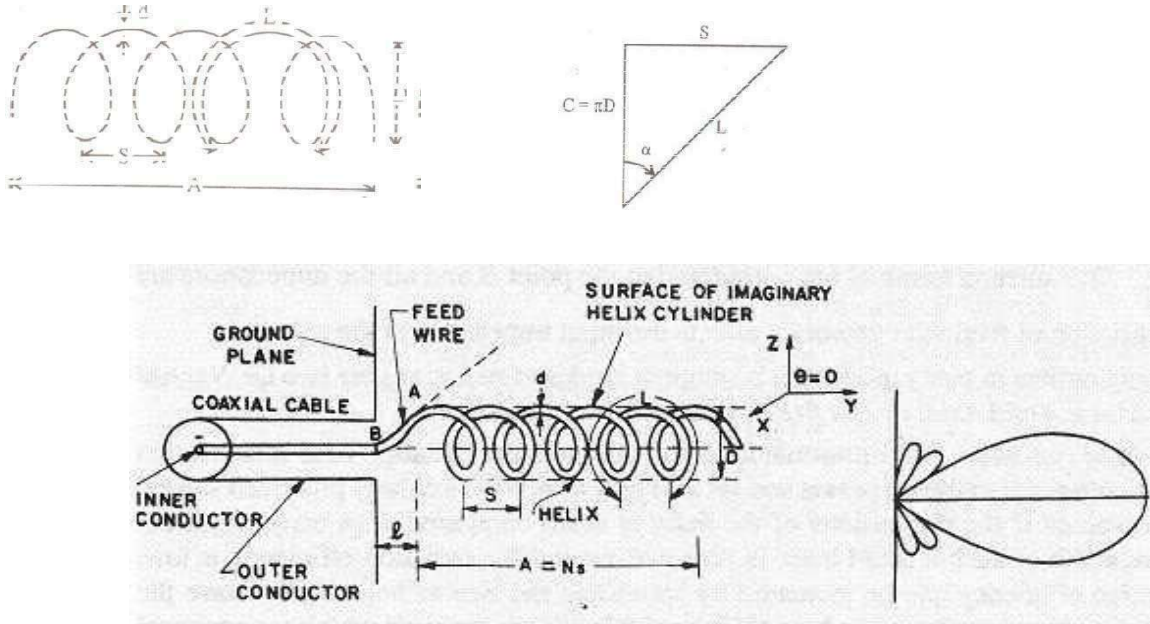

Fig 4.6.1 Helical antenna and its radiation pattern

Here helical antenna is connected between the coaxial cable and ground plane. Ground plane is made of radial and concentric conductors. The radiation characteristics of helical antenna depend upon the diameter (D) and spacing S.

In the above figure,

$$L = \text{length of one turn} = \sqrt{S^2 + (\pi D)^2} \quad N = \text{Number of turns}$$

$$D = \text{Diameter of helix} = \pi D$$

$$\alpha = \text{Pitch angle} = \tan^{-1}(S/\pi D)$$

l = Distance between helix and ground plane.

The radiation characteristics of the antenna can be varied by controlling the size of its geometrical properties compared to the wavelength.

Mode of Operation

→ Normal Mode

→ Axial Mode

1. Normal mode of radiation

Normal mode of radiation characteristics is obtained when dimensions of helical antenna are very small compared to the operating wavelength. Here, the radiation field is maximum in the direction normal to the helical axis. In normal mode, bandwidth and efficiency are very low. The above factors can be increased, by increasing the antenna size. The radiation fields of helical antenna are similar to the loops and short dipoles. So, helical antenna is equivalent to the small loops and short dipoles connected in series.

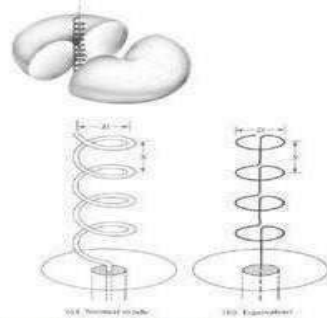

Fig 6.2: Normal mode Helical antenna and its equivalent

We know that, general expression for far field in small loop is,

$$E_{\Phi} = \{120 \pi^2 [I] \sin\theta / r\} [A/\lambda^2]$$

Where,

r = Distance

$I = I_0 \sin \omega(t-r/C) =$ Retarded current

$A =$ Area of loop $= \pi D^2/4$

$D =$ Diameter

$\lambda =$ Operating wavelength.

The performance of helical antenna is measured in terms of Axial Ratio (AR). Axial ratio is defined as the ratio of far fields of short dipole to the small loop.

$$\text{Axial Ratio, } AR = (E_{\theta}) / (E_{\Phi})$$

2. Axial mode of radiation: Helical antenna is operated in axial mode when circumference C and spacing S are in the order of one wavelength. Here, maximum radiation field is along the helical axis and polarization is circular. In axial mode, pitch angle lies between 12° to 18° and beam width and antenna gain depends upon helix length NS .

General expression for terminal impedance is,

$$R = 140C/\lambda \text{ ohms}$$

Where,

$R =$ Terminal impedance

$C =$ Circumference.

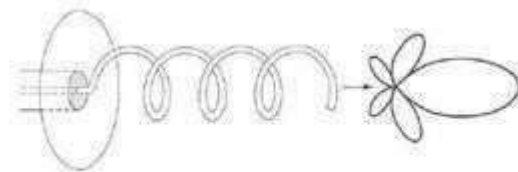

Fig 6.3: Axial mode of helix

In normal mode, beam width and radiation efficiency is very small. The above factors increased by using axial mode of radiation. Half power beam width in axial mode is,

$$\text{HPBW} = 52/C\sqrt{\lambda^3/NS} \text{ Degrees.}$$

Where,

λ = Wavelength

C = Circumference

N = Number of turns

S = Spacing.

Axial Ratio, AR = $1 + 1/2N$

REFLECTOR ANTENNAS

INTRODUCTION

The radiation pattern of a radiating antenna element is modified using reflectors. A simple example is that the backward radiation from an antenna may be eliminated with a large metallic plane sheet reflector. So, the desired characteristics may be produced by means of a large, suitably shaped, and illuminated reflector surface. The characteristics of antennas with sheet reflectors or their equivalent are considered in this chapter.

Some reflectors are illustrated in Figure 3.1. The arrangement in Figure 3.1a has a large, flat sheet reflector near a linear dipole antenna to reduce the backward radiation. With small spacing between the antenna and sheet this arrangement also yields an increase in substantial gain in the forward radiation. The desirable properties of the sheet reflector may be largely preserved with the reflector reduced in size as long as its size is greater than that of the antenna.

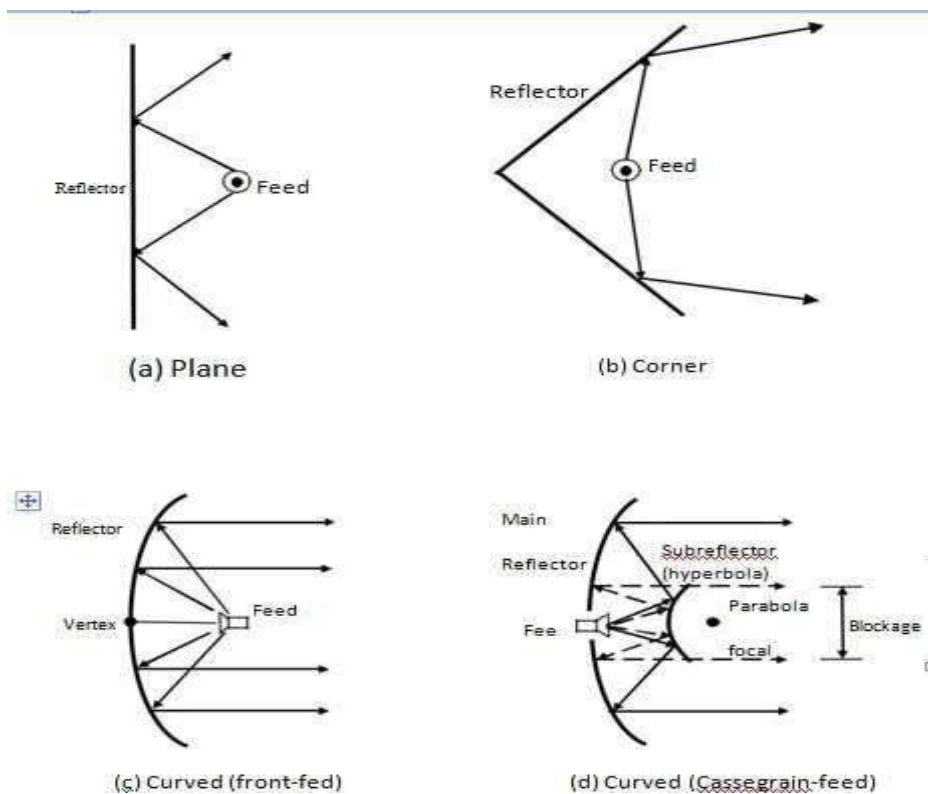

Figure 3.1 Some configurations of reflector antennas

With two flat sheets intersecting at an angle α ($<180^\circ$) as in Figure 3.1b, a sharper radiation pattern than from a flat sheet reflector ($\alpha = 180^\circ$) can be obtained. This arrangement, called *corner reflector antenna*, is most practical where apertures of 1 or 2λ are of convenient size. A corner reflector without an exciting antenna can be used as a *passive reflector* or target for radar

waves. In this application the aperture may be many wavelengths, and the corner angle is *always* 90° . Reflectors with this angle have the property that an incidence wave is reflected back toward its source, the corner acting as a *retroreflector*.

When it is feasible to build antennas with apertures of many wavelengths, parabolic reflectors can be used to provide highly directional antennas. A parabolic reflector antenna is shown in Figure 3.1c. The parabola reflects the waves originating from a source at the focus into a parallel beam, the parabola transforming the curved wave front from the feed antenna at the focus into a plane wave front. A front fed and a cassegrain –feed parabolic reflectors are depicted in Figures 3.1c and d. Many other shapes of reflectors can be employed for special applications. For instance, with an antenna at one focus, the elliptical reflector produces a diverging beam with all reflected waves passing through the second focus of the ellipse. Examples of reflectors of other shapes are the hyperbolic and the spherical reflectors.

The plane sheet reflector, the corner reflector, the parabolic reflector and other reflectors are discussed in more detail in the following sections. In addition, feed systems, aperture blockage, aperture efficiency, diffraction, surface irregularities, gain and frequency-selective surfaces are considered.

PLANE REFLECTORS

Let an omnidirectional antenna is placed at a distance h above an infinite, flat, perfect electric conductor as shown in Figure 3.2. Power from the actual source is radiated in all directions in a manner determined by its unbounded medium directional properties. For an observation point p_1 , there is a direct wave. In addition, a wave from the actual source radiated toward point R_1 of the interface undergoes a reflection. The direction is determined by the law of reflection ($\theta_1^i = \theta_1^r$) which assures that the energy in homogeneous media travels in straight lines along the shortest paths. This wave will pass through the observation point p_1 . By extending its actual path below the interface, it will seem to originate from a virtual source positioned a distance h below the boundary. For another observation point p_2 the point of reflection is R_2 , but the virtual source is the same as before. The same is concluded for all other observation points above the interface. The amount of reflection is generally determined by the respective constitutive parameters of the media below and above the interface. For a perfect electric conductor below the interface, the incidence wave is completely reflected and the field below the boundary is zero. According to the boundary conditions, the tangential components of the electric field must vanish at all points along the interface. Thus for an incident electric field with vertical polarization shown by the arrows, the polarization of the reflected waves must be as indicated in the figure to satisfy the boundary conditions.

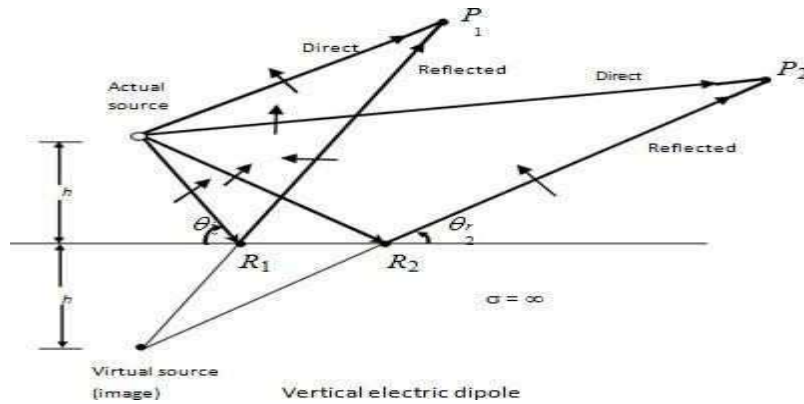

Figure 3.2 Antenna above an infinite, flat, perfect electric conductor.

For a vertical dipole, to excite the polarization of the reflected waves, the virtual source must also be vertical and with a polarity in the same direction as that of the actual source (thus a reflection coefficient of +1). Another orientation of the source will be to have the radiating element in a horizontal position, as shown in Figure 3.3. As shown in Figures 3.3, the virtual source (image) is also placed at a distance h below the interface. For horizontal polarized antenna, the image will have a 180° polarity difference relative to the actual source (thus a reflection coefficient of -1).

In addition to electric sources, artificial equivalent —magnetic sources have been introduced to aid in the analyses of electromagnetic boundary value problems. Figure 3.3 displays the sources and their images for an electric plane conductor. The single arrow indicates an electric element and the double a magnetic one. The direction of the arrow identifies the polarity.

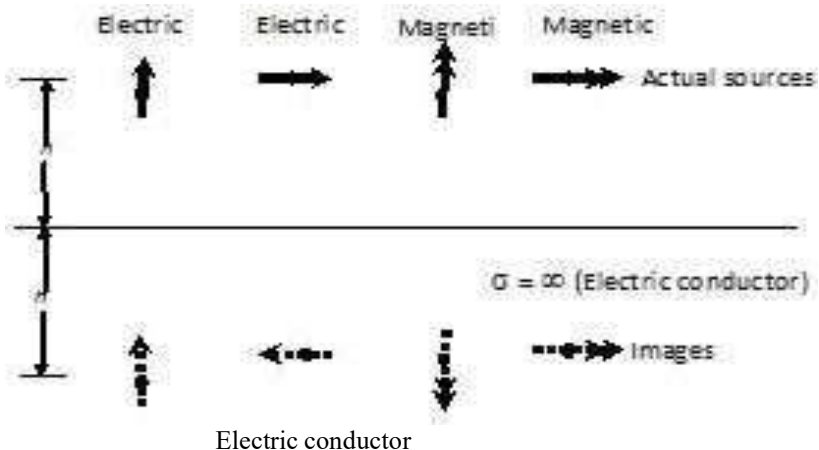

Figure 3.3 Electric and magnetic sources and their images near electric conductors

CORNER REFLECTOR

For better collimation of the power in the forward directions, an arrangement can be made with two plane reflectors joined so as to form a corner, as shown in Figure 3.10 (a). This is known as the corner reflector. Because of its simplicity in construction, it has many unique applications. For example, if the reflector is used as a passive target for radar or communication applications, it will return the signal exactly in the same direction as it received it when its included angle is 90° . This is illustrated geometrically in Figure 3.10(b). Because of this unique feature, military ships and vehicles are designed with minimum sharp corners to reduce their detection by enemy radar.

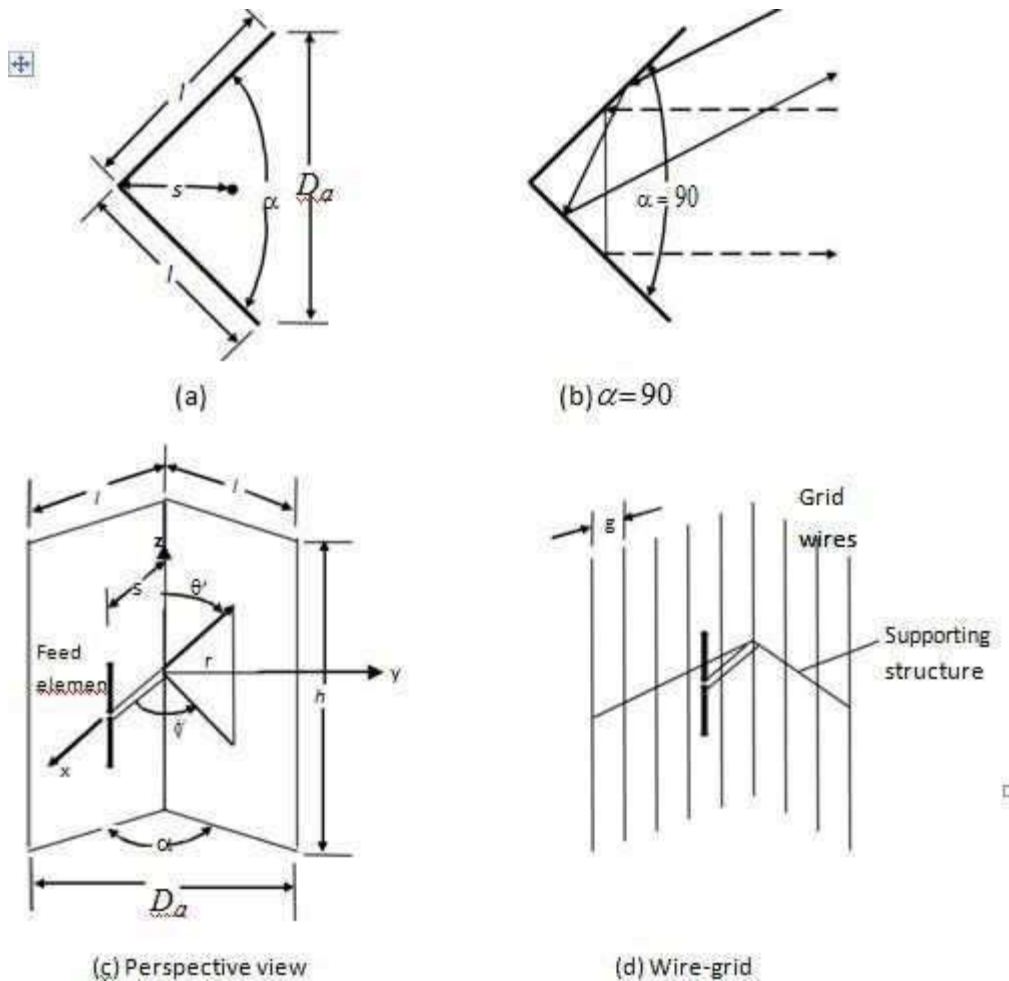

Figure 3.10 Side and perspective views of solid and wire-grid corner reflectors

In most practical applications, the included angle formed by the plates is usually 90° ; however other angles are also used. To maintain a given system efficiency, the spacing between the vertex and the feed element must increase as the included angle of the reflector decreases, and vice-versa. For reflectors with infinite sides, the gain increases as the included angle between the planes decreases. This, however, may not be true for finite size plates. For simplicity, in this

chapter it will be assumed that the plates themselves are infinite in extent ($l = \infty$). However, since in practice the dimensions must be finite, guidelines on the size of aperture D_a , length (l), height (h) is given.

The feed element for a corner reflector is almost always a dipole or an array of collinear dipoles placed parallel to the vertex distance s away. Greater bandwidth is obtained when the feed elements are cylindrical or biconical dipoles instead of thin wires.

In many applications, especially when the wavelength is large compared to tolerable physical dimensions, the surfaces of the corner reflector are frequently made of grid wires rather than solid sheet metal. One of the reasons for doing that is to reduce wind resistance and overall system weight. The spacing g between wires is made a small fraction of a wavelength (usually $g \leq \lambda/10$).

For wires that are parallel to the length of the dipole, as is the case for the arrangement of Figure 3.10(d), the reflectivity of the grid-wire surface is as good as that of a solid surface. In practice, the aperture of the corner reflector (D_a) is usually made between one and two wavelengths ($\lambda < D_a < 2\lambda$). The length of the sides of a 90° corner reflector is most commonly taken to be about twice the distance from the vertex to the feed ($l \approx 2s$).

For reflectors with smaller included angles, the sides are made larger. The feed-to-vertex distance (s) is usually taken to be between $\lambda/3$ and $2\lambda/3$ ($\lambda/3 < s < 2\lambda/3$). For each reflector, there is an optimum feed-to-vertex spacing. If the spacing becomes too small, the radiation resistance decreases and becomes comparable to the loss resistance of the system which leads to an inefficient antenna. For very large spacing, the system produces undesirable multiple lobes, and it loses its directional characteristics. It has been experimentally observed that increasing the size of the sides does not greatly affect the beam width and directivity, but it increases the bandwidth and radiation resistance. The main lobe is somewhat broader for reflectors with finite sides compared to that of infinite dimensions. The height (h) of the reflector is usually taken to be about 1.2 to 1.5 times greater than the total length of the feed element, in order to reduce radiation toward the back region from the ends.

The analysis for the field radiated by a source in the presence of a corner reflector is facilitated when the included angle (α) of the reflector is $\alpha = \pi/n$, where n is an integer ($\alpha = \pi, \pi/2, \pi/3, \pi/4$, etc.). For these cases ($\alpha = 180^\circ, 90^\circ, 60^\circ, 45^\circ$, etc.) it is possible to find a system of images, which when properly placed in the absence of the reflector plates, form an array that yields the same field within the space formed by the reflector plates as the actual system.

The number of images, polarity, and position is controlled by included angle and the polarization of the feed element. The geometrical and electrical arrangement of the images for corner reflectors with included angles of 90°, 60°, 45° and 30°.

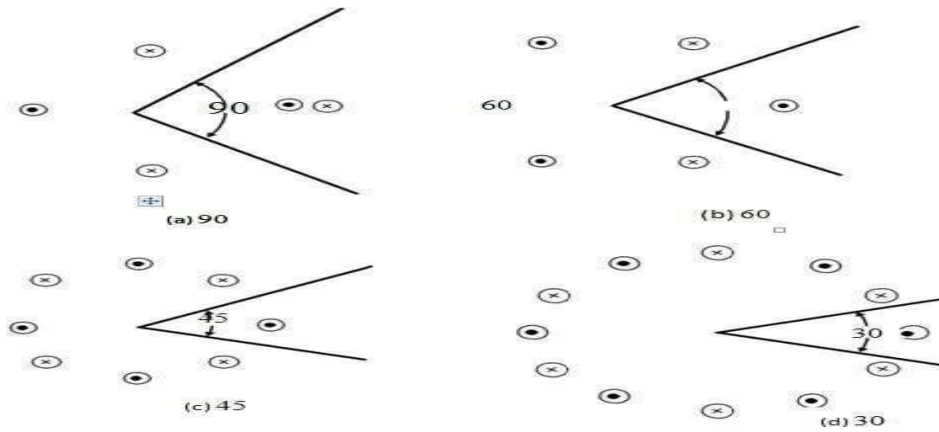

Figure3.11 Corner reflectors and their images (with perpendicularly polarized feeds) for angles of 90 , 60 , 45 and 30 .

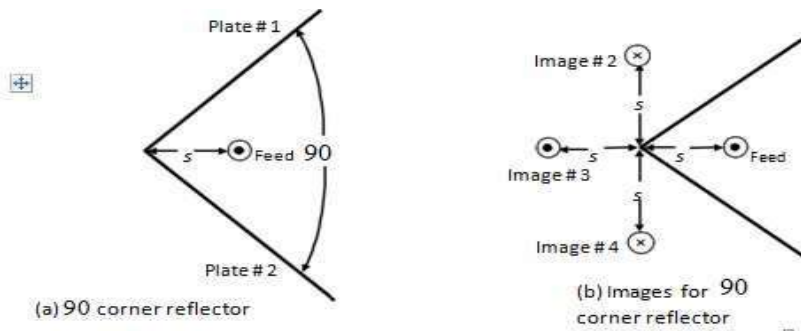

Figure4.12 Geometrical placement and electrical polarity of images for a 90 corner reflector with a parallel polarized feed.

PARABOLIC REFLECTOR

If a beam of parallel rays is incident upon a reflector whose geometrical shape is a parabola, the radiation will converge or get focused at a spot which is known as the *focal point*. In the same manner if a point source is placed at the focal point, the rays reflected by a parabolic reflector will emerge as a parallel beam. The symmetrical point on the parabolic surface is known as the *vertex*. Rays that emerge in a parallel formation are usually said to be *collimated*. In practice, collimation is often used to describe the highly directional characteristics of an antenna even though the emanating rays are not exactly parallel. Since the transmitter (receiver) is placed at the focal point of the parabola, the configuration is usually known as *front fed*.

A parabolic reflector can take two different forms. One configuration is that of the parabolic right cylinder, whose energy is collimated at a line that is parallel to the axis of the cylinder through the focal point of the reflector. The most widely used feed for this type of a reflector is a linear dipole, a linear array, or a slotted waveguide. The other reflector configuration is that which is formed by rotating the parabola around its axis, and it is referred to as a *paraboloid*

(parabola of revolution). A pyramidal or a conical horn has been widely utilized as a feed for this arrangement.

CASSEGRAIN REFLECTORS

The disadvantage of the front-fed arrangement is that the transmission line from the feed must usually be long enough to reach the transmitting or the receiving equipment, which is usually placed behind or below the reflector. This may necessitate the use of long transmission lines whose losses may not be tolerable in many applications, especially in low-noise receiving systems. In some applications, the transmitting or receiving equipment is placed at the focal point to avoid the need for long transmission lines. However, in some of these applications, especially for transmission that may require large amplifiers and for low-noise receiving systems where cooling and weatherproofing may be necessary, the equipment may be too heavy and bulky and will provide undesirable blockage.

The arrangement that avoids placing the feed (transmitter and/or receiver) at the focal point is that shown in Figure 3.1(d) and it is known as the Cassegrain feed. Through geometrical optics, Cassegrain, a famous astronomer (N. Cassegrain of France, hence its name), showed that incident parallel rays can be focused to a point by utilizing two reflectors. To accomplish this, the main (primary) reflector must be a parabola, the secondary reflector (Subreflector) a hyperbola, and the feed placed along the axis of the parabola usually at or near the vertex. Cassegrain used this scheme to construct optical telescopes, and then its design was copied for use in radio frequency systems. For this arrangement, the rays that emanate from the feed illuminate the Subreflector and are reflected by it in the direction of the primary reflector, as if they originated at the focal point of the parabola (primary reflector). The rays are then reflected by the primary reflector and are converted to parallel rays, provided the primary reflector is a parabola and the subreflector is a hyperbola. Diffraction occurs at the edges of the subreflector and primary reflector and they must be taken into account to accurately predict the overall system pattern, especially in regions of low intensity. Even in regions of high intensity, diffraction must be included if an accurate formation of the fine ripple structure of the pattern is desired. With the Cassegrain-feed arrangement, the transmitting and/or receiving equipment can be placed behind the primary reflector. This scheme makes the system relatively more accessible for servicing and adjustments.

Cassegrain designs, employing dual reflector surfaces, are used in applications where pattern control is essential, such as in satellite ground-based systems, and have efficiencies of 65-80%. They supersede the performance of the single-reflector front-fed arrangement by about 10%. Using geometrical optics, the classical Cassegrain configuration, consisting of a paraboloid and hyperboloid, is designed to achieve a uniform phase front in the aperture of the paraboloid. By employing good feed designs, this arrangement can achieve lower spillover and more uniform illumination of the main reflector. In addition, slight shaping of one or both of the dual-reflector's surfaces can lead to an aperture with almost uniform amplitude and phase with

substantial enhancement in gain. These are referred to as shaped reflectors. Shaping techniques have been employed in dual-reflectors used in earth station applications.

Two reflectors with ray geometry, with concept of equivalent parabola, are shown in Figure 3.19. The use of a second reflector, which is usually referred to as the subreflector or subdish, gives an additional degree of freedom for achieving good performance in a number of different applications. For an accurate description of its performance, diffraction techniques must be used to take into account diffractions from the edges of the subreflector, especially when its diameter is small.

In general, the Cassegrain arrangement provides a variety of benefits, such as the

1. ability to place the feed in a convenient location
2. reduction of spillover and minor lobe radiation
3. ability to obtain an equivalent focal length much greater than the physical length
4. capability for scanning and/or broadening of the beam by moving one of the reflecting surfaces

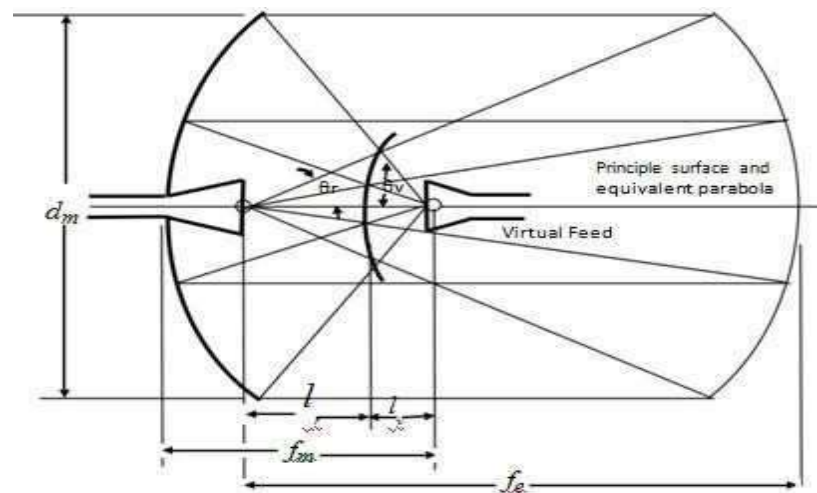

Figure 3.19 Equivalent parabola concepts.

To achieve good radiation characteristics, the subreflector must be few wavelengths in diameter. However, its presence introduces shadowing which is the principle limitation of its use as a microwave antenna. The shadowing can significantly degrade the gain of the system, unless the main reflector is several wavelengths in diameter. Therefore the Cassegrain is usually attractive for applications that require gains of 40 dB or greater. There are, however, a variety of techniques that can be used to minimize the aperture blocking by the subreflector. Some of them are minimum blocking with simple Cassegrain, and twisting Cassegrains for least blocking

Horn Antennas

Flared waveguides that produce a nearly uniform phase front larger than the waveguide itself. Constructed in a variety of shapes such as sectoral E-plane, sectoral H-plane, pyramidal, conical, etc.

Horn Antennas -Application Areas

1. Used as a feed element for large radio astronomy, satellite tracking and communication dishes.
2. A common element of phased arrays.
3. Used in the calibration, other high-gain antennas.
4. Used for making electromagnetic interference measurements

Rectangular Horn antenna:

A rectangular horn antenna is as shown in figure 4.6. This is an extension of rectangular wave guide. TE₁₀ mode is preferred for rectangular horns.

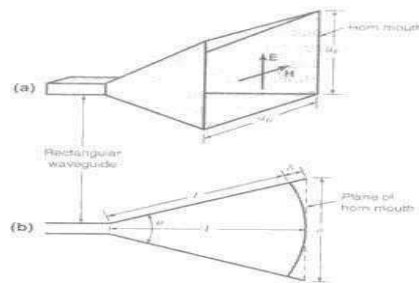

Fig 4.6: Rectangular Horn antenna

Horn antennas are very popular at UHF (300 MHz-3 GHz) and higher frequencies (I've heard of horn antennas operating as high as 140 GHz). Horn antennas often have a directional [radiation pattern](#) with a high [antenna gain](#), which can range up to 25 dB in some cases, with 10-20 dB being typical. Horn antennas have a wide impedance [bandwidth](#), implying that the [input impedance](#) is slowly varying over a wide frequency range (which also implies low values for [S11](#) or [VSWR](#)). The bandwidth for practical horn antennas can be on the order of 20:1 (for instance, operating from 1 GHz-20 GHz), with a 10:1 bandwidth not being uncommon.

The gain of horn antennas often increases (and the [beamwidth](#) decreases) as the frequency of operation is increased. This is because the size of the horn aperture is always measured in wavelengths; at higher frequencies the horn antenna is "electrically larger"; this is because a higher frequency has a smaller wavelength. Since the horn antenna has a fixed physical size (say a square aperture of 20 cm across, for instance), the aperture is more wavelengths across at higher frequencies. And, a recurring theme in antenna theory is that larger antennas (in terms of wavelengths in size) have higher directivities.

Table:

Type of Aperture	Beam width, deg	
	Between First nulls	Between Half power points
Uniformly illuminated rectangular aperture or linear array	$\frac{115}{L_\lambda}$	$\frac{51}{L_\lambda}$
Uniformly illuminated circular aperture	$\frac{140}{D_\lambda}$	$\frac{58}{D_\lambda}$
Optimum E-plane rectangular horn	$\frac{115}{a_{E\lambda}}$	$\frac{56}{a_{E\lambda}}$
Optimum H-plane rectangular horn	$\frac{172}{a_{H\lambda}}$	$\frac{67}{a_{H\lambda}}$

Horn antennas are typically fed by a section of a waveguide, as shown in Figure 4. The waveguide itself is often fed with a [short dipole](#), which is shown in red in Figure 4. A waveguide is simply a hollow, metal cavity (see [the waveguide tutorial](#)). Waveguides are used to guide electromagnetic energy from one place to another. The waveguide in Figure 4 is a rectangular waveguide of width b and height a , with $b > a$. The E-field distribution for the dominant mode is shown in the lower part of Figure 1.

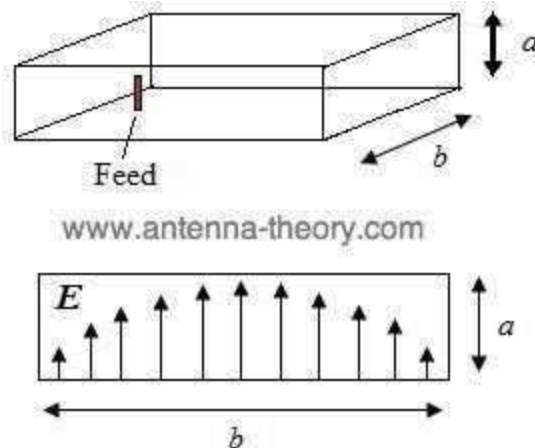

Figure 4. Waveguide used as a feed to horn antennas.

Microstrip Antennas

Introduction

The Microstrip Patch Antenna is a single-layer design which consists generally of four parts (patch, ground plane, substrate, and the feeding part). Patch antenna can be classified as single – element resonant antenna. Once the frequency is given, everything (such as radiation pattern input impedance, etc.) is fixed. The patch is a very thin ($t \ll \lambda_0$, where λ_0 is the free space wavelength) radiating metal strip (or array of strips) located on one side of a thin non conducting substrate, the ground plane is the same metal located on the other side of the substrate. The metallic patch is normally made of thin copper foil plated with a corrosion resistive metal, such as gold, tin, or nickel. Many shapes of patches are designed some are shown in figure (2.1) and the most popular shape is the rectangular and circular patch. The substrate layer thickness is 0.01–0.05 of free-space wavelength (λ_0). It is used primarily to provide proper spacing and mechanical support between the patch and its ground plane. It is also often used with high dielectric-constant material to load the patch and reduce its size. The substrate material should be low in insertion loss with a loss tangent of less than 0.005. In this work we have used Arlon AD 410 with dielectric constant of 4.1 and tangent loss of 0.003. Generally, substrate materials can be separated into three categories according to the dielectric constant ϵ_r [1].

1. Having a relative dielectric constant ϵ_r in the range of 1.0–2.0. This type of material can be air, polystyrene foam, or dielectric honeycomb.
2. Having ϵ_r in the range of 2.0–4.0 with material consisting mostly of fiberglass reinforced Teflon.
3. With an ϵ_r between 4 and 10. The material can consist of ceramic, quartz, or alumina.

The advantages of the microstrip antennas are small size, low profile, and lightweight, conformable to planar and non planar surfaces. It demands a very little volume of the structure when mounting. They are simple and cheap to manufacture using modern printed-circuit technology. However, patch antennas have disadvantages. The main disadvantages of the microstrip antennas are: low efficiency, narrow bandwidth of less than 5%, low RF power due to the small separation between the radiation patch and the ground plane (not suitable for high-power applications).

2.2. Types of Patch Antennas

There are a large number of shapes of microstrip patch antennas; they have been designed to match specific characteristics. Some of the common types are shown in figure (2.1), for millimeter wave frequencies, the most common types are rectangular, square, and circular patches.

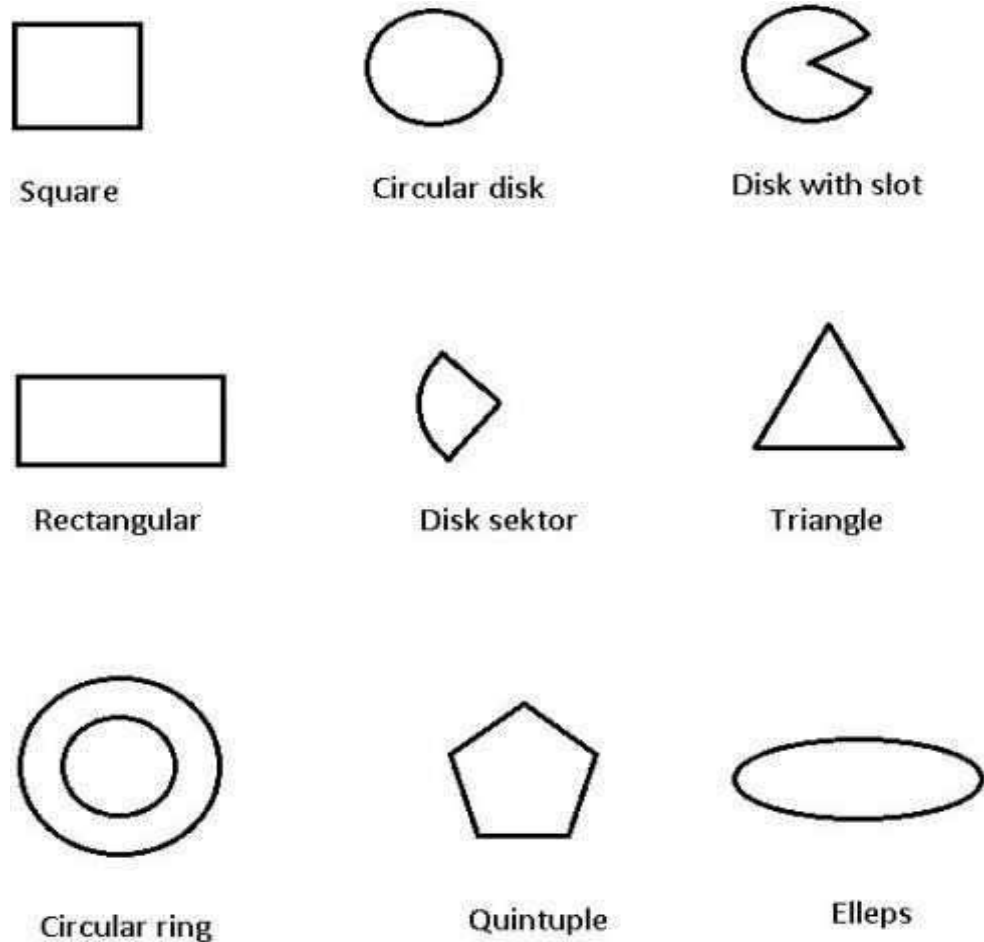

Figure (2.1) the most common shapes of patch antennas

Choose of substrate is also important, we have to consider the temperature, humidity, and other environmental ranges of operating. Thickness of the substrate h has a big effect on the resonant frequency f_r and bandwidth BW of the antenna. Bandwidth of the microstrip antenna will increase with increasing of substrate thickness h but with limits, otherwise the antenna will stop resonating.

2.3. Feeding Methods

There are many methods of feeding a microstrip antenna. The most popular methods are:

1. Microstrip Line.
2. Coaxial Probe (coplanar feed).
3. Proximity Coupling.
4. Aperture Coupling.

Because of the antenna is radiating from one side of the substrate, so it is easy to feed it from the other side (the ground plane), or from the side of the element.

The most important thing to be considered is the maximum transfer of power (matching of the feed line with the input impedance of the antenna), this will be discussed later in the section of Impedance Matching.

Many good designs have been discarded because of their bad feeding. The designer can build an antenna with good characteristics and good radiation parameter and high efficiency but when feeding is bad, the total efficiency could be reduced to a low level which makes the whole system to be rejected.

2.3.1 Microstrip Line Feed.

This method of feeding is very widely used because it is very simple to design and analyze, and very easy to manufacture. Figure (2.2) shows a patch with microstrip line feed from the side of the patch.

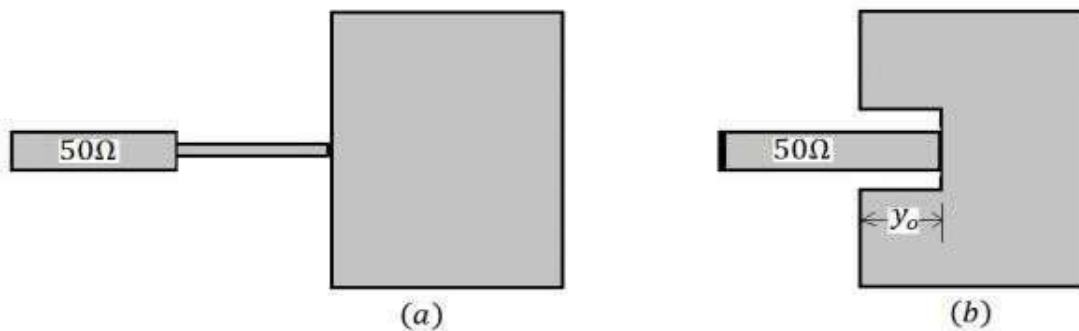

Figure (2.2) Microstrip patch antenna with feed from side

The position of the feed point (y_0) of the patch in figure (2.2b) has been discussed in details in the section of Impedance Matching.

Feeding technique of the patch in figure (2.2a) and figure (2.3) is discussed in [7]. It is widely used in both one patch antenna and multi-patches (array) antennas.

The impedance of the patch is given by [7]:

$$Z_a = 90 \frac{\epsilon_r^2}{\epsilon_r - 1} \left(\frac{L}{W} \right)^2 \quad (2.1)$$

The characteristic impedance of the transition section should be:

$$Z_T = \sqrt{50 + Z_a} \quad (2.2)$$

The width of the transition line is calculated from [7]:

$$Z_T = \frac{60}{\sqrt{\epsilon_r}} \ln\left(\frac{8d}{W_T} + \frac{W_T}{4d}\right) \quad (2.3)$$

The width of the 50Ω microstrip feed can be found using the equation (2.4) below:

$$Z_o = \frac{120\pi}{\sqrt{\epsilon_{reff}} \left(1.393 + \frac{W}{h} + \frac{2}{3} \ln\left(\frac{W}{h} + 1.444\right)\right)} \quad (2.4)$$

Where $Z_o = 50\Omega$

The length of the strip can be found from (4.24)

$$R_{in(x=0)} = \cos^2\left(\frac{\pi}{L}x_o\right) \quad (2.5)$$

The length of the transition line is quarter the wavelength:

$$l = \frac{\lambda}{4} = \frac{\lambda_o}{4\sqrt{\epsilon_{reff}}} \quad (2.6)$$

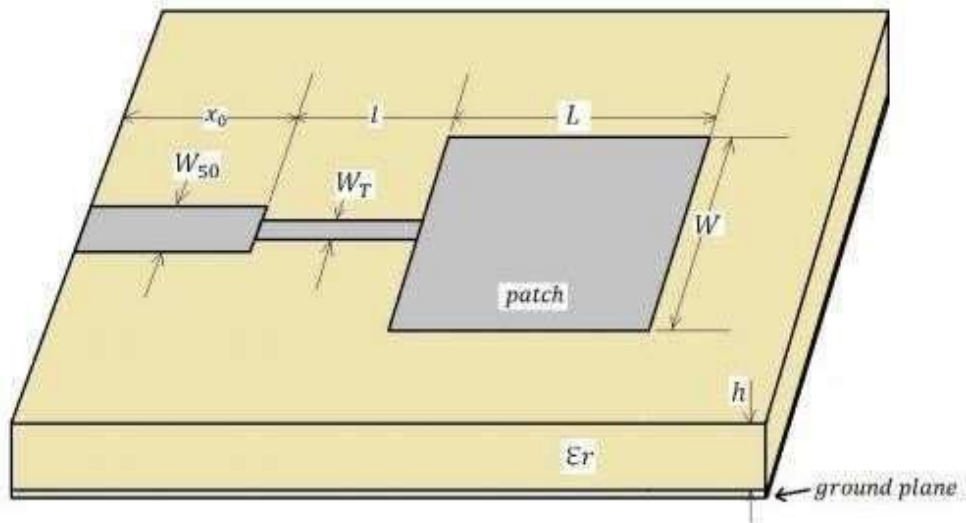

Figure (2.3) Rectangular microstrip patch antenna

UNIT-III

ANTENNA ARRAYS

Antenna Arrays

Antennas with a given radiation pattern may be arranged in a pattern line, circle, plane, etc.) to yield a different radiation pattern.

Antenna array - a configuration of multiple antennas (elements) arranged to achieve a given radiation pattern.

Simple antennas can be combined to achieve desired directional effects. Individual antennas are called elements and the combination is an array

Types of Arrays

Linear array - antenna elements arranged along a straight line.

Circular array - antenna elements arranged around a circular ring.

Planar array - antenna elements arranged over some planar surface (example - rectangular array).

Conformal array - antenna elements arranged to conform to some non-planar surface (such as an aircraft skin).

Design Principles of Arrays

There are several array design variables which can be changed to achieve the overall array pattern design.

Array Design Variables

General array shape (linear, circular, planar)

Element spacing.

Element excitation amplitude.

Element excitation phase.

Patterns of array elements.

Types of Arrays

Broadside: maximum radiation at right angles to main axis of antenna

End-fire: maximum radiation along the main axis of antenna
Phased: all elements connected to source

Parasitic: some elements not connected to source

– They re-radiate power from other elements

Yagi-Uda Array

Often called Yagi array

Parasitic, end-fire, unidirectional

One driven element: dipole or folded dipole

One reflector behind driven element and slightly longer

One or more directors in front of driven element and slightly shorter

Collinear Array

All elements along same axis

Used to provide an omnidirectional horizontal pattern from a vertical antenna
Concentrates radiation in horizontal plane

Broadside Array

Broadside array is one of the most commonly used antenna array in practice. The array in which a number of identical parallel antennas are arranged along a line perpendicular to the line of array axis is known as broadside array, which is shown in figure (2.1). In this, the individual antennas are equally spaced along a line and each element is fed with current of equal magnitude, all in the same phase.

The radiation pattern of broadside array is bidirectional, which radiates equally well in either direction of maximum radiation.

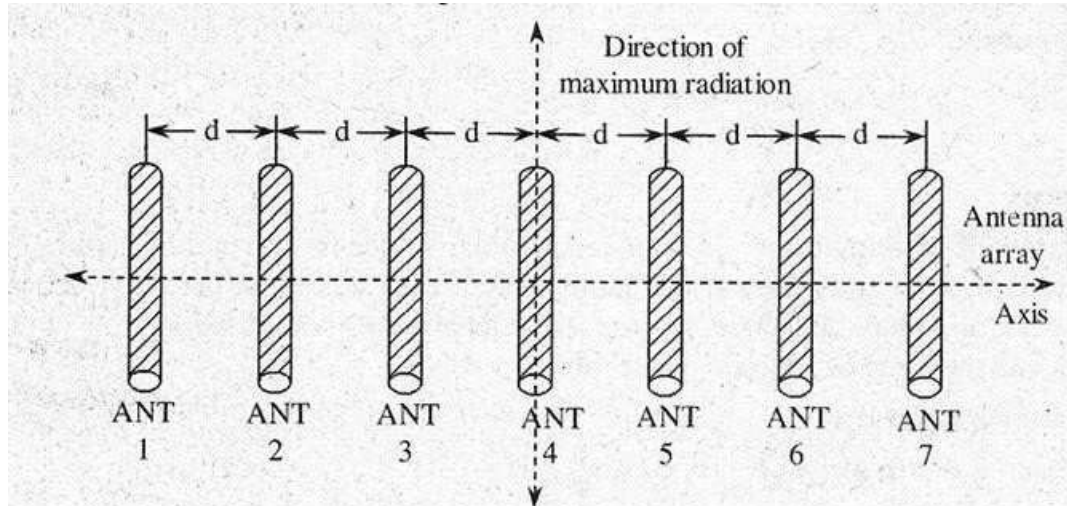

fig 2.1 Board side array

End-Fire Array

The array in which a number of identical antennas are spaced equally along a line and Individual elements are fed with currents of unequal phases (i.e., with a phase shift of 180°) is known as end fire array .This array is similar to that of broadside array except that individual elements are fed in with, a phase shift of 180° .In this, the direction of radiation is coincides with the direction of the array axis, which is shown in figure (2.2).

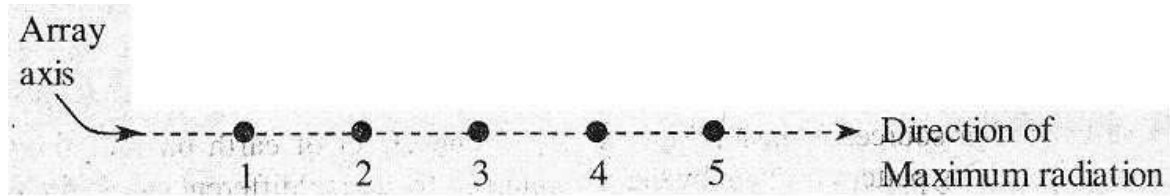

fig 2.2 End fire array

The radiation pattern of end fire array is unidirectional. But, the end fire array may be Bi directional also. One such example is a two element array, fed with equal current, 180° out of phase .

Collinear Array

The array in which antennas are arranged end to end in a single line is known as collinear array. the arrangement of collinear array, in which one antenna is stacked over another antenna. Similar to that of broadside array, the individual elements of the collinear array are fed with equal in phase currents. A collinear array is a broadside radiator, in which the direction of maximum radiation is perpendicular to the line of antenna. The collinear array is sometimes called as broadcast or Omni directional arrays because its radiation pattern has circular symmetry with its main to be everywhere perpendicular to the principal axis.

Application of Arrays

An array of antennas may be used in a variety of ways to improve the performance of a communications system. Perhaps most important is its capability to cancel co channel interferences. An array works on the premise that the desired signal and unwanted co channel interferences arrive from different directions. The beam pattern of the array is adjusted to suit the requirements by combining signals from different antennas with appropriate weighting. An array of antennas mounted on vehicles, ships, aircraft, satellites, and base stations is expected to play an important role in fulfilling the increased demand of channel requirement for these services

ARRAY OF POINT SOURCES

ARRAY is an assembly of antennas in an electrical and geometrical of such a nature that the radiation from each element add up to give a maximum field intensity in a particular direction & cancels in other directions. An important characteristic of an array is the change of its radiation pattern in response to different excitations of its antenna elements.

CASE1: 2 isotropic point sources of same amplitude and phase

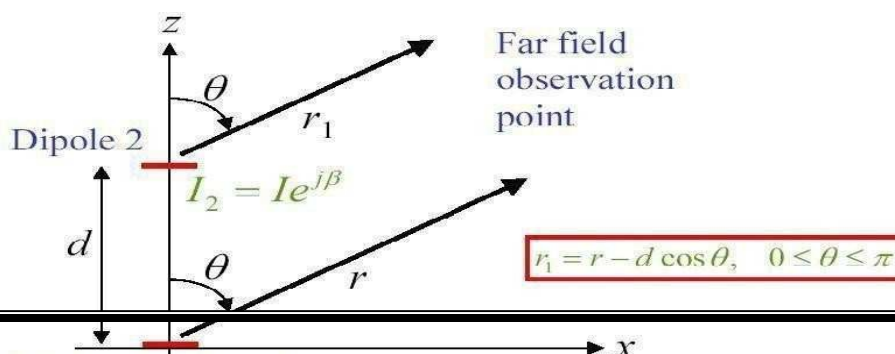

• **Phase difference** = $\beta d/2 \cdot \cos\theta = 2\pi/\lambda \cdot d/2 \cdot \cos\theta$

β = propagation constant

Point sources and Arrays and $d_r = \beta d = 2\pi/\lambda \cdot d =$ **Path difference**

$$E_2 = E_0 \exp(j \cdot \Psi/2)$$

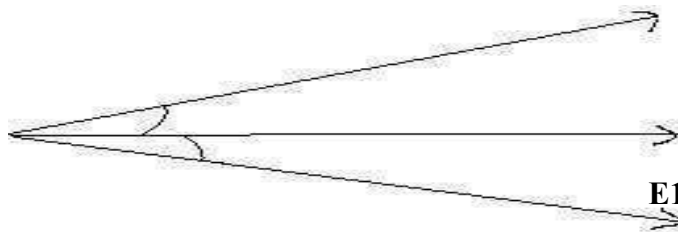

$$E_1 = E_0 \exp(-j \cdot \Psi/2)$$

The total field strength at a large distance r in the direction

θ is :

$$E = E_1 + E_2 = E_0 [\exp(j \cdot \Psi/2) + \exp(-j \cdot \Psi/2)]$$

Therefore: $E = 2E_0 \cos \Psi/2$ (1)

$d_r/2 \cdot \cos \Psi =$ phase difference between E_1 & E_2 & $\Psi/2 = \theta$

$E_0 =$ amplitude of the field at a distance by single isotropic antenna

Substituting for Ψ in (1) & normalizing

$$E = 2E_0 \cos(2\pi/\lambda \cdot d/2 \cdot \cos\theta)$$

$$E_{nor} = \cos(d_r/2 \cdot \cos\theta) \text{ for } d = \lambda/2$$

$$E = \cos(\pi/2 \cdot \cos\theta)$$

At $\theta = \pi/2$ $E = 1$...Point of maxima = $\pi/2$ (or) $3\pi/2$

Point of minima = At $\theta = 0$ $E = 0$0 (or) π At $\theta = \pm\pi/3$ $E = 1/\sqrt{2}$ 3db bandwidth point = $\pm\pi/3$

CASE2: 2 isotropic point sources of same amplitude but opposite phase

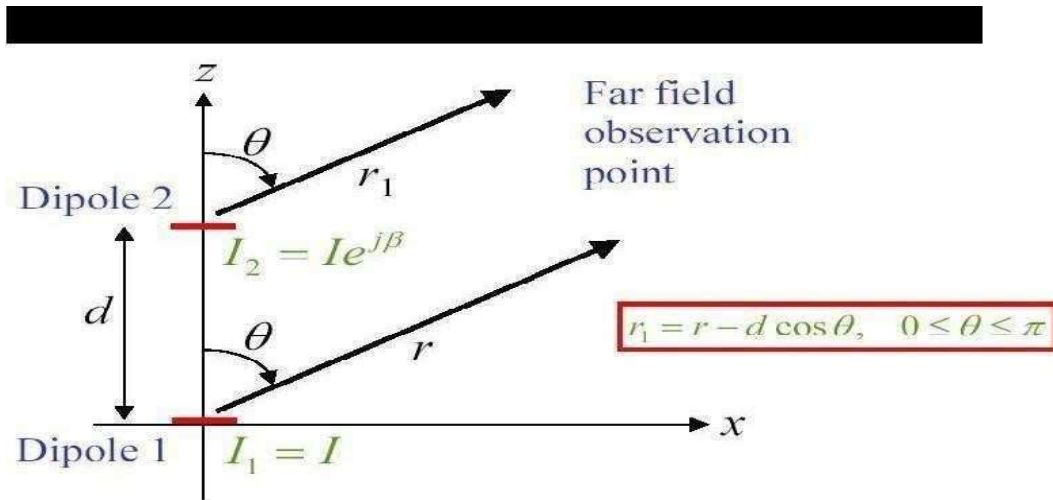

The total field strength at a large distance r in the direction θ is :

$$E = E_1 + E_2 = E_0 [\exp(j\Psi/2) - \exp(-j\Psi/2)]$$

Point sources and Arrays

Therefore: $E = 2jE_0 \text{SIN}(\Psi/2) \dots\dots\dots(2)$

$\Psi =$ phase difference between E_1 & E_2 $\Psi/2 = dr/2 * \cos\theta$

$E_0 =$ amplitude of field at a distance by single isotropic the antenna

At $k=0$ $E = 1$ Point of maxima = 0 (or) π

At $k=0, \theta = \pi/2$ $E = 0$ Point of minima = $\pi/2$ (or) $-\pi/2$

At $\theta = \pm\pi/3$ $E = 1/\sqrt{2}$ 3db bandwidth point = $\pm\pi/3$

Pattern multiplication:

The total far-field radiation pattern $|E|$ of array (array pattern) consists of the original radiation pattern of a single array element multiplying with the magnitude of the array factor $|AF|$. This is a general property of antenna arrays and is called the principle of pattern multiplication.

The total field pattern of an array of non-isotropic but similar sources is the multiplication of the individual source pattern and the pattern of an array of isotropic point sources each located at the phase centre of individual source and having the relative amplitude and phase, where as the total

phase patterns is the addition of the phase pattern of the individual sources and the array of isotropic point sources.

Total field by an array is defined as

$$E = \{ E_0(\theta, \varphi) \times E_i(\theta, \varphi) \} \times \{ E_{pi}(\theta, \varphi) + E_{pa}(\theta, \varphi) \}$$

= (Multiplication of field patterns) (Addition of phase patterns)

Where

E - Total field

$E_0(\theta, \varphi)$ = Field pattern of individual source

$E_i(\theta, \varphi)$ = Field pattern of array of isotropic point source

$E_{pi}(\theta, \varphi)$ = Phase pattern of individual source

$E_{pa}(\theta, \varphi)$ = Phase pattern of array of isotropic point sources.

Hence, θ and φ are polar and azimuth angles respectively.

The principle of multiplication of pattern is best suited for any number of similar sources.

Considering a two dimensional case, the resulting pattern is given by the equation,

$$E = 2 E_0 \cos \varphi / 2$$

$$E = 2 E_1 \sin \theta \cos \varphi / 2.$$

Uniformly excited equally spaced linear arrays

Linear arrays of N-isotropic point sources of equal amplitude and spacing:

An array is said to be linear if the individual elements of the array are spaced equally along a line and uniform if the same are fed with currents of equal amplitude and having a uniform phase shift along the line

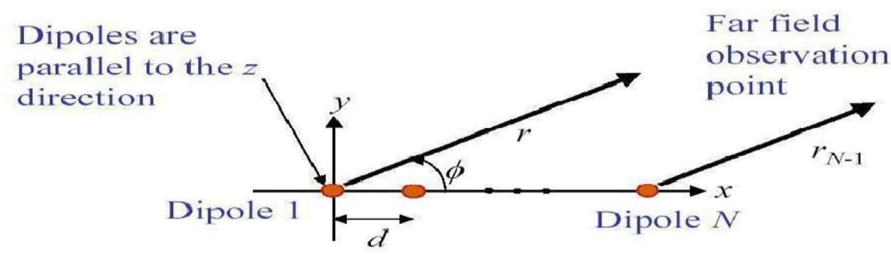

CASE 1: LINEAR BROAD SIDE ARRAY

An array is said to be broadside if the $\theta = \pm 90^\circ$ phase angle is such that it makes maximum radiation perpendicular to the line of array i.e. 90° & 270°

For broad side array $\Psi=0$ & $\delta=0$

Therefore $\Psi = dr \cos \theta + \delta = \beta d \cos \theta + 0 = 0$

therefore $\theta = 90^\circ$ & 270°

Broadside array example for $n=4$ and $d=\lambda/2$

By previous results we have $\theta = 90^\circ$ & 270°

Direction of pattern maxima:

$$E = \frac{1}{n} \frac{\sin(n\Psi/2)}{\sin(\Psi/2)}$$

This is maximum when numerator is maximum i.e. $\sin(n\Psi/2) = 1$

$n\Psi/2 = \pm(2k+1)\pi/2$ where $k=0,1,2,\dots$

$K=0$ major lobe maxima

$K=1$ $n\Psi/2 = \pm 3\pi/2$ $\Psi = \pm 3\pi/4$

Therefore $dr \cos \theta = 2\pi/\lambda * d * \cos \theta = \pm 3\pi/4$

$\cos \theta = \pm 3/4$

$\theta = (\text{max}) \text{minor lobe} = \cos^{-1}(\pm 3/4) = \pm 41.40^\circ$ or $\pm 138.60^\circ = \cos^{-1}(\pm 5/4)$

which is not At $K=2$ possible

Direction of pattern minima or nulls It occurs when numerator=0

i.e. $\sin(n\Psi/2) = 0$ $n\Psi/2 = \pm k\pi$ where $k=1,2,3,\dots$

now using condition $\delta=0$

$\Psi = \pm 2k\pi/n = \pm k\pi/2$ $dr \cos \theta = 2\pi/\lambda * d/2 * \cos \theta$

Hansen-Woodyard End-fire Array (HEEFA)

The end-fire arrays (EFA) have relatively large HPBW as compared to broadside arrays.

To enhance the directivity of an end-fire array, Hansen and Woodyard proposed that the phase shift of an ordinary EFA

$$\beta = \pm kd \tag{14.1}$$

be increased as

$$\beta = -\left(kd + \frac{2.94}{N}\right) \text{ for a maximum at } \theta = 0^\circ, \tag{14.2}$$

$$\beta = +\left(kd + \frac{2.94}{N}\right) \text{ for a maximum at } \theta = 180^\circ. \tag{14.3}$$

Conditions (14.2)–(14.3) are known as the Hansen–Woodyard conditions for end-fire radiation. They follow from a procedure for maximizing the directivity, which we outline below. The normalized pattern AF_n of a uniform linear array is

$$AF_n \approx \frac{\sin \left[\frac{N}{2} (kd \cos \theta + \beta) \right]}{\frac{N}{2} (kd \cos \theta + \beta)} \quad (14.4)$$

if the argument $\psi = kd \cos \theta + \beta$ is sufficiently small (see previous lecture). We are looking for an optimal β , which results in maximum directivity. Let

$$\beta = -pd \quad (14.5)$$

where d is the array spacing and p is the optimization parameter. Then,

$$AF_n = \frac{\sin \left[\frac{Nd}{2} (k \cos \theta - p) \right]}{\frac{Nd}{2} (k \cos \theta - p)}.$$

For brevity, use the notation $Nd/2 = q$. Then

$$AF_n = \frac{\sin [q(k \cos \theta - p)]}{q(k \cos \theta - p)}, \quad (14.6)$$

$$\text{or } AF_n = \frac{\sin Z}{Z}, \text{ where } Z = q(k \cos \theta - p).$$

The radiation intensity becomes

$$U(\theta) = |AF_n|^2 = \frac{\sin^2 Z}{Z^2}, \quad (14.7)$$

$$U(\theta = 0) = \left\{ \frac{\sin[q(k-p)]}{q(k-p)} \right\}^2, \quad (14.8)$$

$$U_n(\theta) = \frac{U(\theta)}{U(\theta = 0)} = \left(\frac{z}{\sin z} \cdot \frac{\sin Z}{Z} \right)^2, \quad (14.9)$$

Where

$$z = q(k-p),$$

$$Z = q(k \cos \theta - p), \text{ and}$$

$U_n(\theta)$ is normalized power pattern with respect to $\theta = 0^\circ$.

The Directivity $\theta = 0^\circ$ is

$$D_0 = \frac{4\pi U(\theta = 0)}{P_{rad}} \quad (14.10)$$

where $P_{rad} = \oint_{\Omega} U_n(\theta) d\Omega$. To maximize the directivity, $U_0 = P_{rad} / 4\pi$ is minimized.

$$U_0 = \frac{1}{4\pi} \int_0^{2\pi} \int_0^\pi \left(\frac{z \sin Z}{\sin z Z} \right)^2 \sin \theta d\theta d\theta, \quad (14.11)$$

$$U_0 = \frac{1}{2} \left(\frac{z}{\sin z} \right)^2 \int_0^\pi \left\{ \frac{\sin[q(k \cos \theta - p)]}{q(k \cos \theta - p)} \right\}^2 \sin \theta d\theta, \quad (14.12)$$

$$U_0 = \frac{1}{2kq} \left(\frac{z}{\sin z} \right)^2 \left[\frac{\pi}{2} + \frac{\cos 2z - 1}{2z} + \text{Si}(2z) \right] = \frac{1}{2kq} g(z). \quad (14.13)$$

Here, $\text{Si}(z) = \int_0^z (\sin t / t) dt$. The minimum of $g(z)$ occurs when

$$z = q(k - p) \approx -1.47, \quad (14.14)$$

$$\Rightarrow \frac{Nd}{2} (k - p) \approx -1.47.$$

$$\Rightarrow \frac{Ndk}{2} - \frac{Ndp}{2} \approx -1.47, \text{ where } dp = -\beta$$

$$\Rightarrow \frac{N}{2} (dk + \beta) \approx -1.47$$

$$\beta \approx -\frac{2.94}{N} - kd = -\left(kd + \frac{2.94}{N} \right). \quad (14.15)$$

Equation (14.15) gives the Hansen-Woodyard condition for improved directivity along $\theta = 0^\circ$. Similarly, for $\theta = 180^\circ$,

$$\beta = +\left(\frac{2.94}{N} + kd \right). \quad (14.16)$$

Usually, conditions (14.15) and (14.16) are approximated by

$$\beta \approx \pm \left(kd + \frac{\pi}{N} \right), \quad (14.17)$$

which is easier to remember and gives almost identical results since the curve $g(z)$ at its minimum is fairly flat.

Conditions (14.15)-(14.16), or (14.17), ensure minimum beamwidth (maximum directivity) in the end-fire direction. There is, however, a trade-off in the side-lobe level, which is higher than that of the ordinary EFA. Besides, conditions (14.15)-(14.16) have to be complemented by additional requirements, which would ensure low level of the radiation in the direction opposite to the main lobe.

(a) Maximum at $\theta = 0^\circ$ [reminder: $\psi = kd \cos \theta + \beta$]

$$\beta = - \left(kd + \frac{2.94}{N} \right) \Big|_{\theta=0^\circ} \Rightarrow \begin{cases} \psi_{\theta=0^\circ} = -\frac{2.94}{N} \\ \psi_{\theta=180^\circ} = -2kd - \frac{2.94}{N} \end{cases} \quad (14.18)$$

Since we want to have a minimum of the pattern in the $\theta = 180^\circ$ direction, we must ensure that

$$|\psi|_{\theta=180^\circ} \approx \pi. \quad (14.19)$$

It is easier to remember the Hansen-Woodyard conditions for maximum directivity in the direction as $\theta=0^\circ$

$$|\psi|_{\theta=0^\circ} = \frac{2.94}{N} \approx \frac{\pi}{N}, \quad |\psi|_{\theta=180^\circ} \approx \pi. \quad (14.20)$$

(b) **Maximum at $\theta = 180^\circ$**

$$\beta = kd + \frac{2.94}{N} \Big|_{\theta=180^\circ} \Rightarrow \begin{cases} \psi_{\theta=180^\circ} = \frac{2.94}{N} \\ \psi_{\theta=0^\circ} = 2kd + \frac{2.94}{N} \end{cases} \quad (14.21)$$

In order to have a minimum of the pattern in the $\theta = 0^\circ$ direction, we must ensure that

$$|\psi|_{\theta=0^\circ} \approx \pi. \quad (14.22)$$

We can now summarize the Hansen-Woodyard conditions for maximum directivity in the $\theta = 180^\circ$ direction as

$$|\psi|_{\theta=180^\circ} = \frac{2.94}{N} \approx \frac{\pi}{N}, \quad |\psi|_{\theta=0^\circ} \approx \pi. \quad (14.23)$$

If (14.19) and (14.22) are not observed, the radiation in the opposite of the desired direction might even exceed the main beam level. It is easy to show that the complementary requirement $|\psi|=\pi$ at the opposite direction can be met if the following relation is observed:

$$d \approx \left(\frac{N-1}{N} \right) \frac{\lambda}{4}. \quad (14.24)$$

If N is large, $d \approx \lambda / 4$. Thus, for a large uniform array, Hansen-Woodyard condition can yield improved directivity only if the spacing between the array elements is approximately $\lambda / 4$.

Directivity of a Linear Array

Directivity of a BSA

$$U(\theta) = |AF_n|^2 = \left[\frac{\sin\left(\frac{N}{2}kd \cos \theta\right)}{\frac{N}{2}kd \cos \theta} \right]^2 = \left(\frac{\sin Z}{Z} \right)^2 \quad (14.25)$$

$$D_0 = 4\pi \frac{U_0}{P_{rad}} = \frac{U_0}{U_{av}}, \quad (14.26)$$

where $U_{av} = P_{rad} / (4\pi)$. The radiation intensity in the direction of maximum radiation $\theta = \pi / 2$ in terms of AF_n is unity:

$$\begin{aligned} U_0 = U_{\max} = U(\theta = \pi / 2) &= 1, \\ \Rightarrow D_0 &= U_{av}^{-1}. \end{aligned} \quad (14.27)$$

The radiation intensity averaged over all directions is calculated as

$$U_{av} = \frac{1}{4\pi} \int_0^{2\pi} \int_0^\pi \frac{\sin^2 Z}{Z^2} \sin \theta d\theta d\phi = \frac{1}{2} \int_0^\pi \left| \frac{\sin\left(\frac{N}{2}kd \cos \theta\right)}{\frac{N}{2}kd \cos \theta} \right|^2 \sin \theta d\theta.$$

Change variable:

$$Z = \frac{N}{2}kd \cos \theta \Rightarrow dZ = -\frac{N}{2}kd \sin \theta d\theta. \quad (14.28)$$

$$U_{av} = -\frac{1}{2N} \frac{2}{kd} \int_{\frac{Nkd}{2}}^{\frac{Nkd}{2}} \left(\frac{\sin Z}{Z} \right)^2 dZ, \quad (14.29)$$

$$U_{av} = \frac{1}{Nkd} \int_{-\frac{Nkd}{2}}^{\frac{Nkd}{2}} \left(\frac{\sin Z}{Z} \right)^2 dZ. \quad (14.30)$$

The function is a relatively fast decaying function as Z increases. That is why, for large arrays, where $Nkd/2$ is big enough (>20), the integral (14.30) can be approximated by

$$U_{av} \approx \frac{1}{Nkd} \int_{-\infty}^{\infty} \left(\frac{\sin Z}{Z} \right)^2 dZ = \frac{\pi}{Nkd}, \quad (14.31)$$

$$D_0 = \frac{1}{U_{av}} \approx \frac{Nkd}{\pi} = 2N \left(\frac{d}{\lambda} \right). \quad (14.32)$$

Substituting the length of the array $L = (N-1)d$ in (14.32) yields

$$D_0 \approx 2 \underbrace{\left(1 + \frac{L}{d} \right)}_N \left(\frac{d}{\lambda} \right). \quad (14.33)$$

For a large array ($L \gg d$),

$$D_0 \approx 2L / \lambda. \quad (14.34)$$

Directivity of ordinary EFA

Consider an EFA with maximum radiation at $\theta = 0^\circ$, i.e., $\beta = -kd$

$$U(\theta) = |AF_n|^2 = \left\{ \frac{\sin \left[\frac{N}{2} kd (\cos \theta - 1) \right]}{\left[\frac{N}{2} kd (\cos \theta - 1) \right]} \right\}^2 = \left(\frac{\sin Z}{Z} \right)^2, \quad (14.35)$$

where $Z = \frac{N}{2} kd (\cos \theta - 1)$. The averaged radiation intensity is

$$U_{av} = \frac{P_{rad}}{4\pi} = \frac{1}{4\pi} \int_0^{2\pi} \int_0^\pi \left(\frac{\sin Z}{Z} \right)^2 \sin \theta d\theta d\phi = \frac{1}{2} \int_0^\pi \left(\frac{\sin Z}{Z} \right)^2 \sin \theta d\theta.$$

Since

$$Z = \frac{N}{2} kd (\cos \theta - 1) \text{ and } dZ = -\frac{N}{2} kd \sin \theta d\theta, \quad (14.36)$$

it follows that

$$U_{av} = \frac{1}{2} \frac{2}{Nkd} \int_0^{-Nkd/2} \left(\frac{\sin Z}{Z} \right)^2 dZ,$$

$$U_{av} = \frac{1}{Nkd} \int_0^{Nkd/2} \left(\frac{\sin Z}{Z} \right)^2 dZ. \quad (14.37)$$

If (Nkd) is sufficiently large, the above integral can be approximated as

$$U_{av} \approx \frac{1}{Nkd} \int_0^{\infty} \left(\frac{\sin Z}{Z} \right)^2 dZ = \frac{1}{Nkd} \cdot \frac{\pi}{2}. \quad (14.38)$$

The directivity then becomes

$$\Rightarrow D_0 \approx \frac{1}{U_{av}} = \frac{2Nkd}{\pi} = 4N \left(\frac{d}{\lambda} \right). \quad (14.39)$$

The comparison of (14.39) and (14.32) shows that the directivity of an EFA is approximately twice as large as the directivity of the BSA.

Another (equivalent) expression can be derived for D_0 of the EFA in terms of the array length $L = (N-1)d$:

$$D_0 = 4 \left(1 + \frac{L}{d} \right) \left(\frac{d}{\lambda} \right). \quad (14.40)$$

For large arrays, the following approximation holds:

$$D_0 = 4L / \lambda \quad \text{if } L \gg d. \quad (14.41)$$

Directivity of HE EFA

If the radiation has its maximum at $\theta=0^\circ$, then the minimum of U_{av} is obtained as in (14.13):

$$U_{av}^{\min} = \frac{1}{2k} \frac{2}{Nd} \left[\frac{Z_{\min}}{\sin Z_{\min}} \right]^2 \left[\frac{\pi}{2} + \frac{\cos(2Z_{\min}) - 1}{2Z_{\min}} + \text{Si}(2Z_{\min}) \right], \quad (14.42)$$

where $Z_{\min} = -1.47 \approx -\pi/2$.

$$\Rightarrow U_{av}^{\min} = \frac{1}{Nkd} \left(\frac{\pi}{2} \right)^2 \left[\frac{\pi}{2} + \frac{2}{\pi} - 1.8515 \right] = \frac{0.878}{Nkd}. \quad (14.43)$$

The directivity is then

$$D_0 = \frac{1}{U_{av}^{\min}} = \frac{Nkd}{0.878} = 1.789 \left[4N \left(\frac{d}{\lambda} \right) \right]. \quad (14.44)$$

From (14.44), we can see that using the HW conditions leads to improvement of the directivity of the EFA with a factor of 1.789. Equation (14.44) can be expressed via the length L of the array as

$$D_0 = 1.789 \left[4 \left(1 + \frac{L}{d} \right) \left(\frac{d}{\lambda} \right) \right] = 1.789 \left[4 \left(\frac{L}{\lambda} \right) \right]. \quad (14.45)$$

Advantages of Linear Arrays with Nonuniform Amplitude Distribution

The most often met BSAs, classified according to the type of their excitation amplitudes, are:

- a) the uniform BSA – relatively high directivity, but the side-lobe levels are high;
- b) Dolph–Tschebyscheff (or Chebyshev) BSA – for a given number of elements, maximum directivity is next after that of the uniform BSA; side-lobe levels are the lowest in comparison with the other two types of arrays for a given directivity;
- c) binomial BSA – does not have good directivity but has very low side-lobe levels (when $d=\lambda/2$, there are no side lobes at all).

Array Factor of Linear Arrays with Nonuniform Amplitude Distribution

Let us consider a linear array with an even number ($2M$) of elements, located symmetrically along the z -axis, with excitation, which is also symmetrical with respect to $z=0$. For a broadside Array ($\beta=0$)

$$AF^e = a_1 e^{j\frac{1}{2}kd \cos \theta} + a_2 e^{j\frac{3}{2}kd \cos \theta} + \dots + a_M e^{j\frac{2M-1}{2}kd \cos \theta} + \quad (15.1)$$

$$+ a_1 e^{-j\frac{1}{2}kd \cos \theta} + a_2 e^{-j\frac{3}{2}kd \cos \theta} + \dots + a_M e^{-j\frac{2M-1}{2}kd \cos \theta},$$

$$\Rightarrow AF^e = 2 \sum_{n=1}^M a_n \cos \left[\left(\frac{2n-1}{2} \right) kd \cos \theta \right]. \quad (15.2)$$

If the linear array consists of an odd number $(2M+1)$ of elements, located symmetrically along the z -axis, the array factor is

$$AF^o = 2a_1 + a_2 e^{jkd \cos \theta} + a_3 e^{j2kd \cos \theta} + \dots + a_{M+1} e^{jMkd \cos \theta} + \quad (15.3)$$

$$+ a_2 e^{-jkd \cos \theta} + a_3 e^{-j2kd \cos \theta} + \dots + a_{M+1} e^{-jMkd \cos \theta},$$

$$\Rightarrow AF^o = 2 \sum_{n=1}^{M+1} a_n \cos[(n-1)kd \cos \theta].$$

(15.4)

EVEN- AND ODD-NUMBER ARRAYS

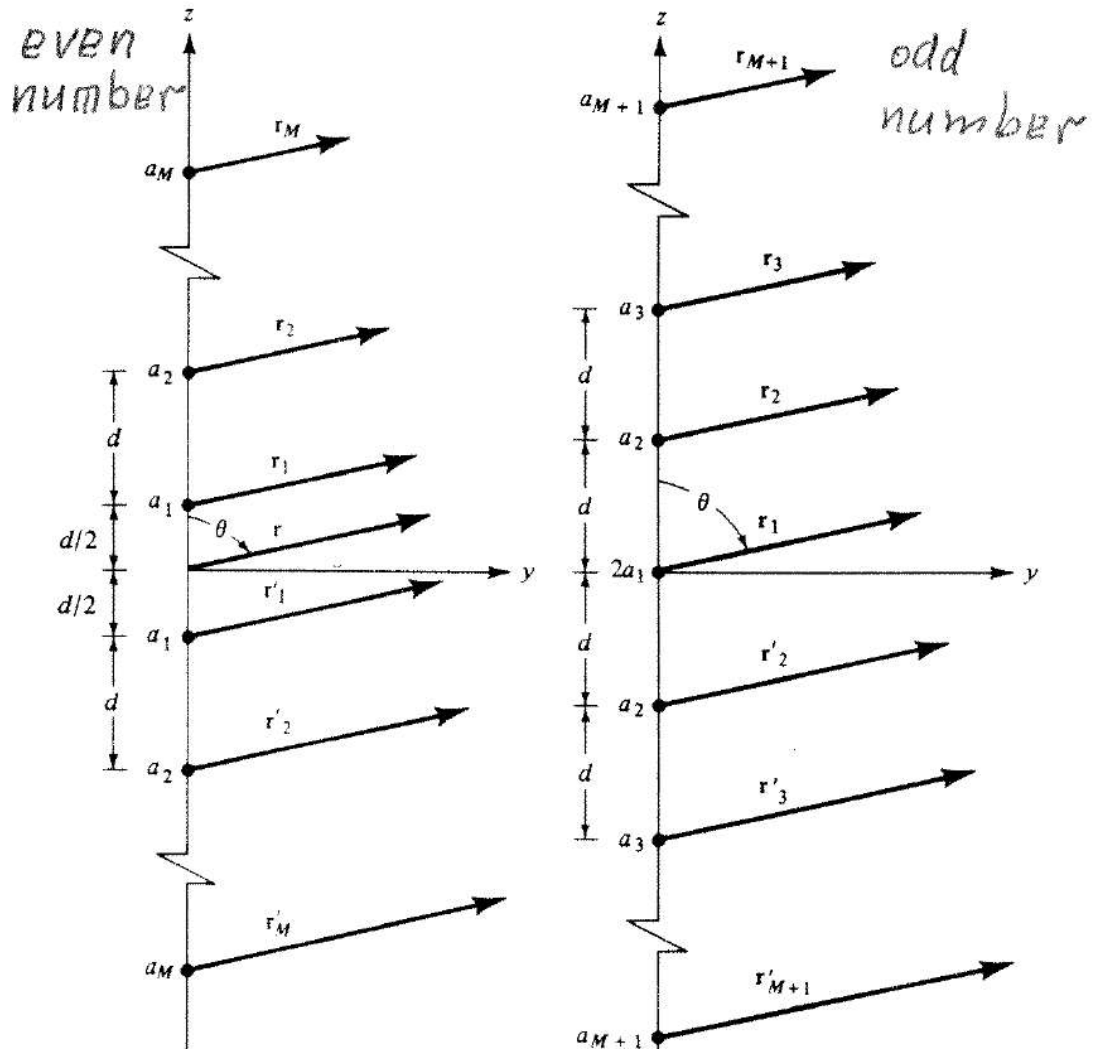

The normalized AF derived from (15.2) and (15.4) can be written in the form

$$AF^e = \sum_{n=1}^M a_n \cos[(2n-1)u], \text{ for } N = 2M, \quad (15.5)$$

$$AF^o = \sum_{n=1}^{M+1} a_n \cos[2(n-1)u], \text{ for } N = 2M + 1, \quad (15.6)$$

where $u = \frac{1}{2}kd \cos \theta = \frac{\pi d}{\lambda} \cos \theta$.

Binomial Broadside Array

The binomial BSA was investigated and proposed by J. S. Stone to synthesize patterns without side lobes. First, consider a 2-element array (along the z -axis).

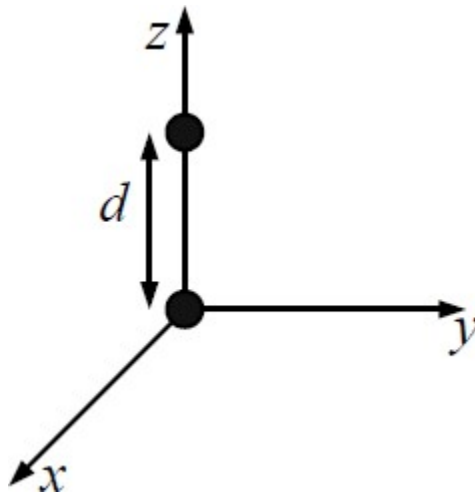

The elements of the array are identical and their excitations are the same. The array factor is of the form

$$AF = 1 + Z, \text{ where } Z = e^{j\psi} = e^{j(kd \cos \theta + \beta)}. \quad (15.7)$$

If the spacing is $d \leq \lambda / 2$ and $\beta = 0$ (broad-side maximum), the array pattern $|AF|$ has no side lobes at all. This is proven as follows.

$$|AF|^2 = (1 + \cos\psi)^2 + \sin^2\psi = 2(1 + \cos\psi) = 4\cos^2(\psi/2) \quad (15.8)$$

where $\psi = kd \cos\theta$. The first null of the array factor is obtained from (15.8) as

$$\frac{1}{2} \cdot \frac{2\pi}{\lambda} \cdot d \cos\theta_{n1,2} = \pm \frac{\pi}{2} \Rightarrow \theta_{n1,2} = \pm \arccos\left(\frac{\lambda}{2d}\right). \quad (15.9)$$

As long as $d < \lambda / 2$, the first null does not exist. If $d = \lambda / 2$, then $\theta_{n1,2} = 0, 180^\circ$. Thus, in the “visible” range of θ , all secondary lobes are eliminated.

Second, consider a 2–element array whose elements are identical and the same as the array given above. The distance between the two arrays is again d .

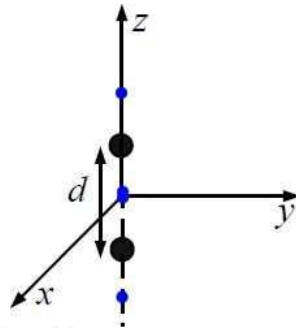

This new array has an AF of the form

$$AF = (1 + Z)(1 + Z) = 1 + 2Z + Z^2. \quad (15.10)$$

Since $(1 + Z)$ has no side lobes, $(1 + Z)^2$ does not have side lobes either.

Continuing the process for an N -element array produces

$$AF = (1 + Z)^{N-1}. \quad (15.11)$$

If $d \leq \lambda / 2$, the above AF does not have side lobes regardless of the number of elements N . The excitation amplitude distribution can be obtained easily by the expansion of the binome in (15.11). Making use of Pascal's triangle,

$$\begin{array}{c}
 1 \\
 1 \ 1 \\
 1 \ 2 \ 1 \\
 1 \ 3 \ 3 \ 1 \\
 1 \ 4 \ 6 \ 4 \ 1 \\
 1 \ 5 \ 10 \ 10 \ 5 \ 1
 \end{array}$$

the relative excitation amplitudes at each element of an $(N+1)$ -element array can be determined. An array with a binomial distribution of the excitation amplitudes is called a **binomial array**. The excitation distribution as given by the binomial expansion gives the *relative* values of the amplitudes. It is immediately seen that there is too wide variation of the amplitude, which is a disadvantage of the BAs. The overall efficiency of such an antenna would be low. Besides, the BA has relatively wide beam. Its HPBW is the largest as compared to the uniform BSA or the Dolph–Chebyshev array.

An approximate closed-form expression for the HPBW of a BA with $d = \lambda / 2$ is

$$HPBW \approx \frac{1.06}{\sqrt{N-1}} = \frac{1.06}{\sqrt{2L/\lambda}} = \frac{1.75}{\sqrt{L/\lambda}}, \quad (15.12)$$

where $L = (N-1)d$ is the array's length. The AFs of 10-element broadside binomial arrays ($N = 10$) are given below.

The directivity of a broadside BA with spacing $d = \lambda / 2$ can be calculated as

$$D_0 = \frac{2}{\int_0^\pi \left[\cos\left(\frac{\pi}{2} \cos\theta\right) \right]^{2(N-1)} d\theta}, \quad (15.13)$$

$$D_0 = \frac{(2N-2) \cdot (2N-4) \cdot \dots \cdot 2}{(2N-3) \cdot (2N-5) \cdot \dots \cdot 1}, \quad (15.14)$$

$$D_0 \approx 1.77\sqrt{N} = 1.77\sqrt{1+2L/\lambda}. \quad (15.15)$$

Dolph–Chebyshev Array (DCA)

Dolph proposed (in 1946) a method to design arrays with any desired side-lobe levels and any HPBWs. This method is based on the approximation of the pattern of the array by a Chebyshev polynomial of order m , high enough to meet the requirement for the side-lobe levels. A DCA with no side lobes (side-lobe level of $-\infty$ dB) reduces to the binomial design.

Chebyshev polynomials

The Chebyshev polynomial of order m is defined by

$$T_m(z) = \begin{cases} (-1)^m \cosh(m \cdot \operatorname{arccosh} |z|), & z \leq -1, \\ \cos(m \cdot \arccos(z)), & -1 \leq z \leq 1, \\ \cosh(m \cdot \operatorname{arccosh}(z)), & z \geq 1. \end{cases} \quad (15.16)$$

A Chebyshev polynomial $T_m(z)$ of any order m can be derived via a recursion formula, provided $T_{m-1}(z)$ and $T_{m-2}(z)$ are known:

$$T_m(z) = 2zT_{m-1}(z) - T_{m-2}(z). \quad (15.17)$$

Explicitly, from (15.16) we see that

$$m = 0, \quad T_0(z) = 1$$

$$m = 1, \quad T_1(z) = z.$$

Then, (15.17) produces:

$$m = 2, \quad T_2(z) = 2z^2 - 1$$

$$m = 3, \quad T_3(z) = 4z^3 - 3z$$

$$m = 4, \quad T_4(z) = 8z^4 - 8z^2 + 1$$

$$m = 5, \quad T_5(z) = 16z^5 - 20z^3 + 5z, \text{ etc.}$$

If, $z \leq 1$ then the Chebyshev polynomials are related to the cosine functions, see (15.16). We can always expand the function $\cos(mx)$ as a polynomial of $\cos(x)$ of order m , e.g., for, $m=2$,

$$\cos 2x = 2 \cos^2 x - 1. \quad (15.18)$$

The expansion of $\cos(mx)$ can be done by observing that $(ejx)^m = e^{jmx}$ and by making use of Euler's formula as

$$(\cos x + j \sin x)^m = \cos(mx) + j \sin(mx). \quad (15.19)$$

The left side of the equation is then expanded and its real and imaginary parts are equated to those on the right. Similar relations hold for the hyperbolic cosine function \cosh .

Comparing the trigonometric relation in (15.18) with the expression for $T_2(z)$ above (see the expanded Chebyshev polynomials after (15.17)), we see that the Chebyshev argument z is related to the cosine argument x by

$$z = \cos x \quad \text{or} \quad x = \arccos z. \quad (15.20)$$

For example, (15.18) can be written as:

$$\begin{aligned} \cos(2 \arccos z) &= 2[\cos(\arccos z)]^2 - 1, \\ \Rightarrow \cos(2 \arccos z) &= 2z^2 - 1 = T_2(z). \end{aligned} \quad (15.21)$$

Properties of the Chebyshev polynomials:

- 1) All polynomials of any order m pass through the point (1,1).
- 2) Within the range $-1 \leq z \leq 1$ the polynomials have values within $[-1, 1]$.
- 3) All nulls occur within $-1 \leq z \leq 1$
- 4) The maxima and minima in the $z \in [-1, 1]$ range have values +1 and -1, respectively.
- 5) The higher the order of the polynomial, the steeper the slope for $z > 1$.

Chebyshev array design

The main goal is to approximate the desired AF with a Chebyshev polynomial such that

- the side-lobe level meets the requirements, and
- the main beam width is as small as possible.

An array of N elements has an AF approximated with a Chebyshev polynomial of order m , which is

$$m = N - 1. \quad (15.22)$$

In general, for a given side-lobe level, the higher the order m of the polynomial, the narrower the beamwidth. However, for $m > 10$, the difference is not substantial – see the slopes $T_m(z)$ of in the previous figure. The AF of an N -element array (15.5) or (15.6) is shaped by a Chebyshev polynomial by requiring that

$$T_{N-1}(z) = \begin{cases} \sum_{n=1}^M a_n \cos[(2n-1)u], & M = N/2, \quad \text{even} \\ \sum_{n=1}^{M+1} a_n \cos[2(n-1)u], & M = (N-1)/2, \quad \text{odd} \end{cases} \quad (15.23)$$

Here, $u = (\pi d / \lambda) \cos \theta$. Let the side-lobe level be

$$R_0 = \frac{E_{\max}}{E_{sl}} = \frac{1}{AF_{sl}} \quad (\text{voltage ratio}). \quad (15.24)$$

Then, we require that the maximum of T_{N-1} is fixed at an argument z_0 ($|z_0| > 1$), where

$$T_{N-1}^{\max}(z_0) = R_0. \quad (15.25)$$

Equation (15.25) corresponds to $AF(u) = AF^{\max}(u_0)$. Obviously, z_0 must satisfy the condition:

$$|z_0| > 1, \quad (15.26)$$

Where $T_{N-1} > 1$. The maxima of $|T_{N-1}(z)|$ for $|z| \leq 1$ are equal to unity and they correspond to the side lobes of the AF. Thus, has side-lobe levels equal to R_0 . The AF is a polynomial of $\cos u$, and the $T_{N-1}(z)$ is a polynomial of z where z is limited to the range

$$-1 \leq z \leq z_0. \quad (15.27)$$

Since

$$-1 \leq \cos u \leq 1, \quad (15.28)$$

the relation between z and $\cos u$ must be normalized as

$$\cos u = z / z_0. \quad (15.29)$$

Antenna Measurements

Testing of real antennas is fundamental to antenna theory. All the antenna theory in the world doesn't add up to a hill of beans if the antennas under test don't perform as desired. **Antenna Measurements** is a science unto itself; as a very good antenna measurer once said to me "good antenna measurements don't just happen".

What exactly are we looking for when we test or measure antennas?

Basically, we want to measure many of the fundamental parameters listed on the Antenna Basics page. The most common and desired measurements are an antenna's radiation pattern including antenna gain, Directivity.

Required Equipment in Antenna Measurements

For antenna test equipment, we will attempt to illuminate the test antenna (often called an Antenna-Under-Test) with a plane wave. This will be approximated by using a source (transmitting) antenna with known radiation pattern and characteristics, in such a way that the fields incident upon the test antenna are approximately plane waves. More will be discussed about this in the next section. The required equipment for antenna measurements include:

A source antenna and transmitter - This antenna will have a known pattern that can be used to illuminate the test antenna

A receiver system - This determines how much power is received by the test antenna

A positioning system - This system is used to rotate the test antenna relative to the source antenna, to measure the radiation pattern as a function of angle.

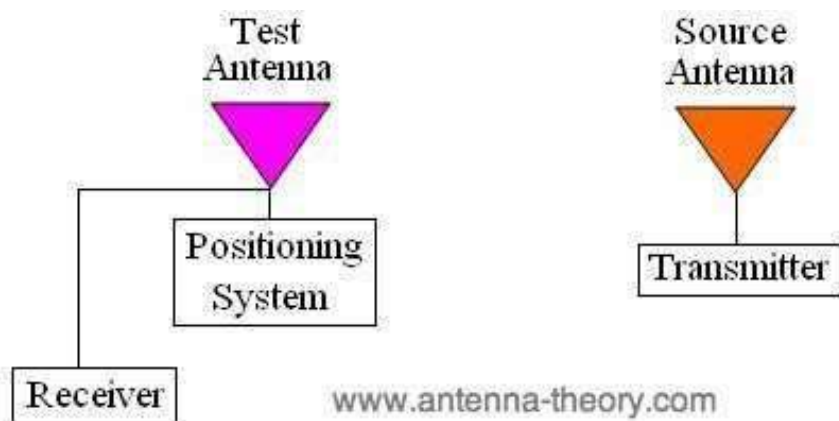

UNIT-IV

EAVE PROPAGATION-I

Ground Eave Propagation:-

Propagation of EM wave near earth surface(including troposphere).When the Transmit and Receive antenna are on earth there can be multiple paths for communication. If the Transmit and Receive antenna are in line of sight (LOS)then direct path exist. The propagating wave is called direct wave. When EM wave encounters an interface between two dissimilar media, a part of energy will flow along the interface Known as Surface Wave. At LF and MF this is predominant mode of energy transfer for vertically polarized radiation. Interaction with the objects on ground will manifestas, Reflection, Refraction, Diffraction, Scattering. Waves are collectively called as Space Wave.

Ground Reflection:

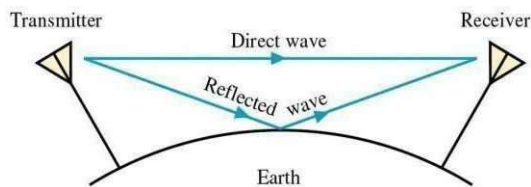

In LOS model,the assumption is that there is only one path for propagation of EM Wave from transmit antenna to receive antenna. The two antennas are kept in free space with no other objects intersecting radiation from transmitter antenna.If two antennas are situated close the ground due to discontinuity in the electrical properties at the air ground interface any wave that falls on the ground is reflected. The amount of reflection depending on factors like angle of incidence,Polarization of wave, Electrical Properties of the Ground i.e conductivity and dielectric constant,the frequency of the propagatingwave.Thus,the field at any point above the ground is a vector sum of the fields due to the direct and the reflected waves.

Direct Eave:-

It is limited to—line-of sight transmission distances. The limiting factors are antenna height and curvature of earth. The Radiohorizonisabout80%greaterthanline of sight because of diffraction effects. A Part of the signal from the transmitter is bounced off the ground and reflected back to the receiving antenna. If the phase between the direct wave and the reflected wave are not in phase can cause problems

Detune the antenna so that the reflected wave is too weak to receive

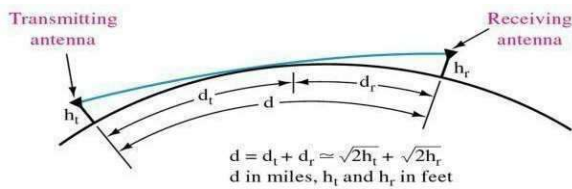

SURFACE WAVE

Travels directly without reflection on ground. Occurs when both antennas are in LOS

Spacewave bend near ground follows a curved path. Antennas must display a very low angle of emission. Power radiated must be in direction of the horizon instead of escaping in sky. A high gain and horizontally polarized antenna is recommended.

If dipole and the fieldpoints are on the surface of the earth but separated by a distance, We have $R_2=R_1=d$ and $\psi=0$

If ground has finite conductivity (typically 10^{-3}S/m - $30 \times 10^{-3}\text{S/m}$) then $\epsilon = -1$,

The EF due to the direct and ground reflected wave will cancel each other. The EF due to the direct and ground reflected wave is also known as surface wave. Surface wave constitute the primary mode of propagation for frequencies in the range of few KHz - several MHz. In AM broadcast application, A vertical monopole above the ground is used to radiate power in the MW frequency band. The receivers are placed very close to the surface of the earth and hence they receive the broadcast signal via surface wave. Achieve Propagation over hundreds of kilometers. Attenuation factor of the surface wave depends on

1. Distance between the transmitter and receiver.
2. The frequency of the electrical properties of the ground over which the

Ground propagates. At the surface of the earth the attenuation is also known as the ground wave attenuation factor and is designated as A_{su}

The numerical distance $p = (\pi R / \lambda \chi) \cos b$, where b is the power factor angle $b = \tan^{-1}(r + 1/\chi)$

Where R is the distance between the transmit and receive antennas and χ is given as

$$\chi = \zeta / \omega \epsilon_0$$

For $\chi \gg r$ the power factor angle is nearly zero and the ground is almost resistive.

For a 1MHz wave propagating over a ground surface with $\zeta = 12 \times 10^{-3}\text{S/m}$ and $r = 15$ the value of χ is 215.7 and is much greater than r .

The power factor angle is 4.25° . At higher frequency 100MHz the value of χ is 2.157 and power factor angle becomes 82.32°

For large numerical distance the attenuation factor decreases by a factor of 10 for every decade i.e 20dB/decade. Thus attenuation is inversely proportional to p and R .

The electric field intensity due to the surface wave is proportional to the product of A_s and $e^{-\alpha R}$. The EF due to the surface wave at large distance from vertically polarized antenna is inversely proportional to the surface of the distance or the power is inversely proportional to R^4 .

The EF of a vertically polarized wave near the surface of the earth have a forward tilt. The magnitude of the wave tilt depends on the conductivity and permittivity of the earth. The horizontal component is smaller than the vertical component and they are not in phase. The EF is elliptically polarized very close to the surface of the earth.

SPACE WAVE

The space wave follows two distinct paths from the transmitting antenna to the receiving antenna—one through the air directly to the receiving antenna, the other reflected from the ground to the receiving antenna. The primary path of the space wave is directly from the transmitting antenna to the receiving antenna. So, the receiving antenna must be located within the radio horizon of the transmitting antenna. Because space waves are refracted slightly, even when propagated through the troposphere, the radio horizon is actually about one-third farther than the line-of-sight or natural horizon.

Although space waves suffer little ground attenuation, they nevertheless are susceptible to fading. This is because space waves actually follow two paths of different lengths (direct path and ground reflected path) to the receiving site and, therefore, may arrive in or out of phase. If these two component waves are received in phase, the result is a reinforced or stronger signal. Likewise, if they are received out of phase, they tend to cancel one another, which results in a weak or fading signal.

Sky Wave

The sky wave, often called the ionospheric wave, is radiated in an upward direction and returned to Earth at some distant location because of refraction from the ionosphere. This form of propagation is relatively unaffected by the Earth's surface and can propagate signals over great distances. Usually the high frequency (hf) band is used for sky wave propagation. The following in-depth study of the ionosphere and its effect on sky waves will help you to better understand the nature of sky wave propagation.

TROPOSPHERIC PROPAGATION:

The lowest part of the earth's atmosphere is called the troposphere. Typically, the troposphere extends from the surface of the earth to an altitude of approximately 9km at the poles and 17km at the equator. This upper boundary is referred to as the tropopause and is defined as the point at which the temperature in the atmosphere begins to increase with height. Within the troposphere, the temperature is found to decrease with altitude at a rate of approximately 7°C per km. The earth's weather system is confined to the troposphere and the fluctuations in weather parameters like temperature, pressure and humidity cause the refractive index of the air in this layer to vary from one point to another. It is in this context that the troposphere assumes a vital role in the propagation of radio waves at VHF (30-300MHz) and UHF (300-3000MHz) frequencies. The meteorological conditions therefore influence the manner in which radio wave propagation occurs in the troposphere both on a spatial and temporal scale.

Refractive Index, Refractivity and Modified Refractivity

Transhorizon Radiowave Propagation due to Evaporation Ducting, The Effect of Tropospheric Weather Conditions on VHF and UHF Radio Paths Over the Sea

In general, the refractive index, n , of the troposphere decreases with altitude. To simplify the mathematics involved, variations in the horizontal are neglected and horizontal homogeneity of the refractive index of the troposphere is assumed in most discussions on this topic. A typical value for n at sea level is 1.000350. A few feet above sea level, this might decrease to a value such as 1.000300. For all practical purposes, at this scale, this change in the refractive index is negligibly small, with hardly any visible deviation. However, immediately above the surface of the sea, it is often this small (but rapid) change in the refractive index profile that facilitates the formation of meteorological phenomena called evaporation ducts. A convenient way of expressing these unwieldy numbers is to use the concept of refractivity instead. Refractivity, N , is defined as follows:

$$N = (n-1) \times 10^6$$

So, for example, when $n=1.000350$, $N=350$.

A well-known approximation for refractivity N is given below

$$N = \frac{77.6}{T} \left(P + \frac{4810 \cdot e}{T} \right)$$

Where P = total atmospheric pressure (in mb); T = atmospheric temperature (in K);
 e = water vapour pressure (in mb).

All three terms, P , T and e fall with height in an exponential manner, resulting in a corresponding decrease in N with height. A standard atmosphere, therefore, is one in which the refractivity varies with altitude according to equation. Using Snell's law, a radio ray projected into the atmosphere will have to travel from a denser to a rarer medium and will refract downwards towards the surface of the earth. The curvature of the ray, however, will still be less than the earth's curvature. The gradient of refractivity in this case generally

varies from 0 to -79N- units per kilo. When the refractivity gradient varies from -79 to -157N-units per kilo, as a super refractive condition is said to prevail in the troposphere and the ray will refract downwards at a rate greater than standard but less than the curvature of the earth. A refractivity gradient that is even less than -157N-units per kilo will result in a ray that refracts towards the earth's surface with a curvature that exceeds the curvature of the earth. This situation is referred to as trapping and is of particular importance in the context of evaporation ducts. Finally, if the refractivity gradient is greater than 0N units per kilo, a sub refractive condition exists and a radio ray will now refract upwards, away from the surface of the earth.

Depending on the existing conditions in the troposphere, a radio wave will undergo any of the types of refraction: sub refraction, standard refraction, super refraction or trapping. Figure 1 illustrates the four refractive conditions discussed above.

While dealing with radio propagation profiles, the curved radio rays are replaced with line arrays for the purpose of geometric simplicity. To account for drawing radio rays as straight lines, the earth radius has to be increased. The radius of this virtual sphere is

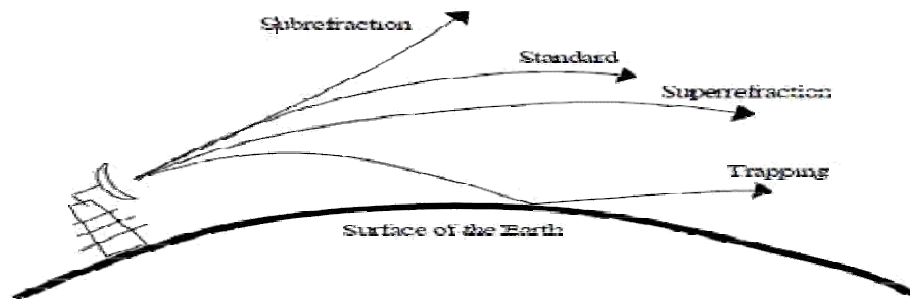

Known as the effective earth radius and it is approximately equal to four-thirds the true radius of the earth (i.e. roughly 8500km). A more classical form of representing n is that of modified refractivity, M . In this case, the surface of the earth is represented by a flat plane and the radio rays are constituted by curves that are determined by Snell's law and the corresponding value of M at each point along the radio link. The following is the expression for M

$$M = N + \left(\frac{h}{a}\right) * 10^6$$

$$N + 0.157h,$$

Where N =refractivity (in N-units), h = height above sea level (ins), a =radius of the earth (in s).

Formation of Evaporation Ducts

The air that is in immediate contact with these a surface is saturated with water vapour. As the height increases, the water vapour pressure in the atmosphere rapidly decreases until it reaches an ambient value at which it remains more or less static for a further increase in

height. There fore, for the first fews above the surface of the sea, it is the water vapour pressure, e , in the expression for N that dominates. This rapid decrease in e causes a steep fall in N .

This is reflected in the modified refractivity , M , which also correspondingly decreases.(The height term h ,which increases,is more than off set by the rapidly decreasing N term). This behavior can be seen in the graph of h vs M

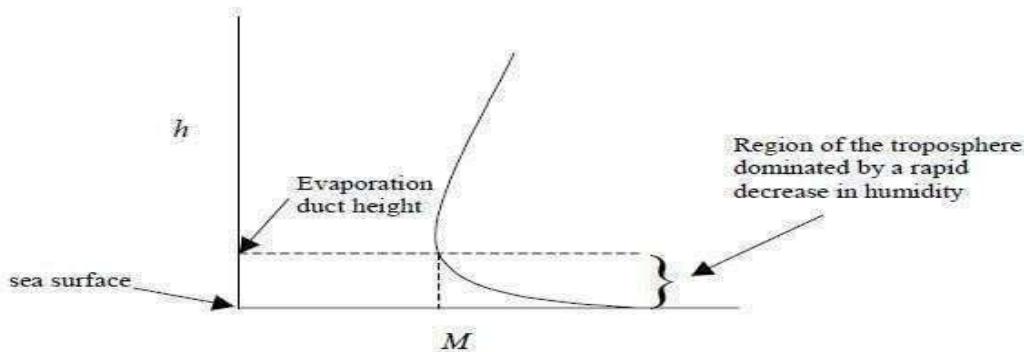

As that portion of the curve with a strong negative M gradient. Therefore, despite the fact that the height h is increasing, it is the sharp fall in the water vapour pressure, e , that contributes to the rapid decrease in M .

Once e has reached its ambient value at a given height, a further rise in altitude does not cause a substantial change in the humidity of the troposphere. Thus, as h increases further, N decreases more (since air pressure and temperature both decrease with height). But this decrease in N is very small over large height increments. Consequently, despite a decreasing N term, it is the h term that starts to domain at e in the expression for M . Thus,

M now gradually increases with height , and can be seen as the portion of the curve that has a positive M gradient.

The point at which the M gradient changes from negative to positive is referred to as the evaporation duct height(or thickness),and is a practical and realistic measure of the strength of the evaporation duct.

Evaporation Ducts and the Troposphere

By virtue of their nature of formation, evaporation ducts are nearly permanent features over the sea surface. Typically, the height of an evaporation duct is of the order of only a fews; however, this can vary considerably with geographical location and changes in atmospheric parameters such as humidity, air pressure and temperature. In the lower regions of the troposphere where the earth's weather is confined, these parameters do, in fact, fluctuate significantly. The turbulent nature of the atmosphere contributes to its unpredictability and a variable atmosphere, in turn, is one of the major causes of unreliable wireless communications. Depending on their location and the prevailing climate, evaporation duct heights may vary from a few meters to few tens of meters. Additionally, it is observed that calm sea conditions are more conducive for the creation of ducts. As a consequence of sporadic meteorological phenomena, evaporation duct heights undergo significant spatial and temporal variations. Evaporation ducts are weather-related phenomena; their heights cannot easily be measured directly using instruments like refractometers and radiosondes.

At best, the height of an evaporation duct can be deduced from the bulk meteorological parameters that are representative of the ongoing physical processes at the air-sea boundary. The dependence of evaporation ducts on the physical structure of the troposphere signifies that changing weather conditions can indeed result in alterations in radio wave propagation.

Evaporation Ducts and Radio wave Propagation

Over the years, much research has been undertaken to explain the mechanism of radio wave propagation in evaporation ducts. A key reason why evaporation ducts are so important for radio communications is because they are often associated with enhanced signal strengths at receivers. An evaporation duct can be regarded as a natural waveguide that steers the radio signal from the transmitter to a receiver that may be situated well beyond the radio horizon. The drop in the refractive index of the atmosphere within the first few meters above the surface of the sea causes incident radio waves to be refracted towards the earth more than normal so that their radius of curvature becomes less than or equal to that of the earth's surface. The sudden change in the atmosphere's refractivity at the top of the duct causes the radio waves to refract back into the duct, and when it comes in contact with the surface of the sea, it gets reflected upwards again. The waves then propagate long ranges by means of successive reflections (refractions) from the top of the duct and the surface of the earth.

Since the top of an evaporation duct is not 'solid' (as in the case of an actual waveguide), there will be a small but finite amount of energy leakage into the freespace immediately above the duct. However, despite this escape of energy, radiowaves are still capable of travelling great distances through the duct, with relatively small attenuation and path loss. The ducting effect then results in radio signals reaching places that are beyond the radio horizon with improved signal strengths. This naturally has far reaching implications on practical radio propagation patterns. For this reason, evaporation ducts and their impact on radio wave propagation have been studied extensively over the years. Numerous statistical models have been proposed to describe evaporation ducts and compute the duct heights under different atmospheric conditions.

The presence of evaporation ducts might not always indicate enhanced signal strengths. For instance, if there is an unwanted distant transmitter also located within the duct, then there is always the possibility of the system under consideration being susceptible to signal interference and interception. This is dependent on the location of the radio paths being investigated. An other scenario that might arise is the interference between the various propagation modes that exist within the evaporation duct itself. Depending on the separation of the transmitter and receiver and the prevailing atmospheric conditions, there could be destructive interference between the direct and reflected rays, the latter of which is comprised of the various multiple hop (one-hop, two-hop, and so on) propagation modes. Additionally, signal degradation may also occur if there is destructive interference between various modes that arrive at the receiver after refraction from different heights in the troposphere. All these situations could possibly cause key problems in the domain of cellular mobile communication systems in littoral regions. Thus, in addition to aiding radio wave propagation, evaporation ducts could also be principal limiting factors in beyond line of sight over-the-sea UHF propagation.

UNIT V

WAVE PROPAGATION-II

Introduction of Sky Wave Propagation or IONOSPHERIC Wave Propagation

Medium and high frequencies of 2 to 30 MHz

Reflection from the ionized region in the upper atmosphere called Ionosphere (50Km to 400Km above earth surface).

Ionosphere – act as a reflected surface

More than 30 MHz- not reflected & penetrate into Ionosphere.

Reflection from Ionosphere called as ionosphere propagation.

Suitable for 2 to 30 MHz called as short wave propagation.

Long distance point to point communication called as point to point propagation.

Possible with multiple reflection extremely long distance communication.

STRUCTURE OF THE IONOSPHERE

As we stated earlier, the ionosphere is the region of the atmosphere that extends from about 30 miles above the surface of the Earth to about 250 miles. It is appropriately named the ionosphere because it consists of several layers of electrically charged gas atoms called ions. The ions are formed by a process called ionization.

Ionization

Ionization occurs when high energy ultraviolet light waves from the sun enter the ionospheric region of the atmosphere, strike a gas atom, and literally knock an electron free from its parent atom. A normal atom is electrically neutral since it contains both a positive proton in its nucleus and a negative orbiting electron. When the negative electron is knocked free from the atom, the atom becomes positively charged (called a positive ion) and remains in space along with the free electron, which is negatively charged. This process of upsetting electrical neutrality is known as IONIZATION. The free negative electrons subsequently absorb part of the ultraviolet energy, which initially freed them from their atoms. As the ultraviolet light wave continues to produce positive ions and negative electrons, its intensity decreases because of the absorption of energy by the free electrons, and an ionized layer is formed.

The rate at which ionization occurs depends on the density of atoms in the atmosphere and the intensity of the ultraviolet light wave, which varies with the activity of the sun.

Since the atmosphere is bombarded by ultraviolet light waves of different frequencies, several ionized layers are formed at different altitudes. Lower frequency ultraviolet waves penetrate the

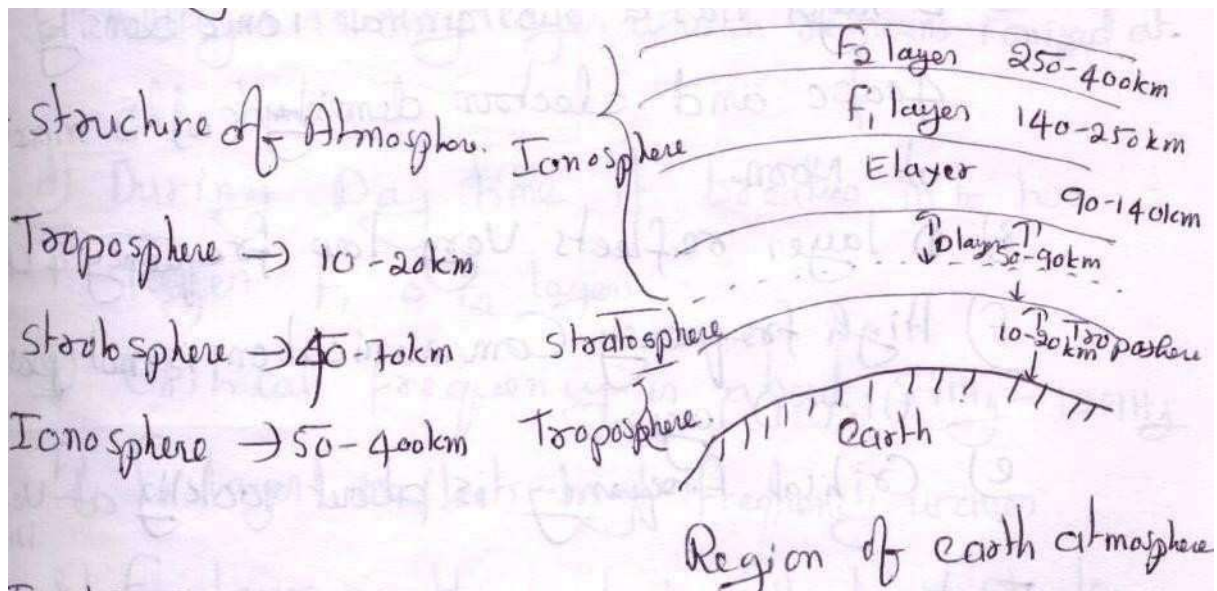

atmosphere the least; therefore, they produce ionized layers at the higher altitudes. Conversely, ultraviolet waves of higher frequencies penetrate deeper and produce layers at the lower altitudes. An important factor in determining the density of ionized layers is the elevation angle of the sun, which changes frequently. For this reason, the height and thickness of the ionized layers vary, depending on the time of day and even the season of the year. Recombination Recall that the process of ionization involves ultraviolet light waves knocking electrons free from their atoms. A reverse process called RECOMBINATION occurs when the free electrons and positive ions collide with each other. Since these collisions are inevitable, the positive ions return to their original neutral atom state.

The recombination process also depends on the time of day. Between the hours of early morning and late afternoon, the rate of ionization exceeds the rate of recombination. During this period, the ionized layers reach their greatest density and exert maximum influence on radio waves.

During the late afternoon and early evening hours, however, the rate of recombination exceeds the rate of ionization, and the density of the ionized layers begins to decrease. Throughout the night, density continues to decrease, reaching a low point just before sunrise.

Four Distinct Layers

The ionosphere is composed of three layers designated D, E, and F, from lowest level to highest level as shown in figure, The F layer is further divided into two layers designated F₁ (the lower layer) and F₂ (the higher layer). The presence or absence of these layers in the ionosphere and their height above the Earth varies with the position of the sun. At high noon, radiation in the ionosphere directly above a given point is greatest. At night it is minimum. When the radiation is removed, many of the particles that were ionized recombine. The time interval between these conditions finds the position and number of the ionized layers within the ionosphere changing.

Since the position of the sun varies daily, monthly, and yearly, with respect to a specified point on Earth, the exact position and number of layers present are extremely difficult to determine.

However, the following general statements can be made:

The D layer ranges from about 30 to 55 miles. Ionization in the D layer is low because it is the lowest region of the ionosphere. This layer has the ability to refract signals of low frequencies. High frequencies pass right through it and are attenuated. After sunset, the D layer disappears because of the rapid recombination of ions.

b. The E layer limits are from about 55 to 90 miles. This layer is also known as the Kennelly-Heaviside layer, because these two men were the first to propose its existence. The rate of ionic recombination in this layer is rather rapid after sunset and the layer is almost gone by midnight. This layer has the ability to refract signals as high as 20 megahertz. For this reason, it is valuable for communications in ranges up to about 1500 miles.

c. The F layer exists from about 90 to 240 miles. During the daylight hours, the F layer separates into two layers, the F1 and F2 layers. The ionization level in these layers is quite high and varies widely during the day. At noon, this portion of the atmosphere is closest to the sun and the degree of ionization is maximum. Since the atmosphere is rarefied at these heights, recombination occurs slowly after sunset. Therefore, a fairly constant ionized layer is always present. The F layers are responsible for high-frequency, long distance transmission.

REFRACTION IN THE IONOSPHERE

When a radio wave is transmitted into an ionized layer, refraction, or bending of the wave, occurs. As we discussed earlier, refraction is caused by an abrupt change in the velocity of the upper part of a radio wave as it strikes or enters a new medium. The amount of refraction that occurs depends on three main factors: (1) the density of ionization of the layer, (2) the frequency of the radio wave, and (3) the angle at which the wave enters the layer.

Density of Layer the relationship between radio waves and ionization density. Each ionized layer has a central region of relatively dense ionization, which tapers off in intensity both above and below the maximum region. As a radio wave enters a region of **INCREASING** ionization, the increase in velocity of the upper part of the wave causes it to be bent back **TOWARD** the Earth. While the wave is in the highly dense center portion of the layer, however, refraction occurs more slowly because the density of ionization is almost uniform. As the wave enters into the upper part of the layer of **DECREASING** ionization, the velocity of the upper part of the wave decreases, and the wave is bent **AWAY** from the Earth.

If a wave strikes a thin, very highly ionized layer, the wave may be bent back so rapidly that it will appear to have been reflected instead of refracted back to Earth. To reflect a radio wave, the highly ionized layer must be approximately no thicker than one wavelength of the radio wave.

Since the ionized layers are often several miles thick, ionospheric reflection is more likely to occur at long wavelengths (low frequencies).

Day and night structure of ionosphere:

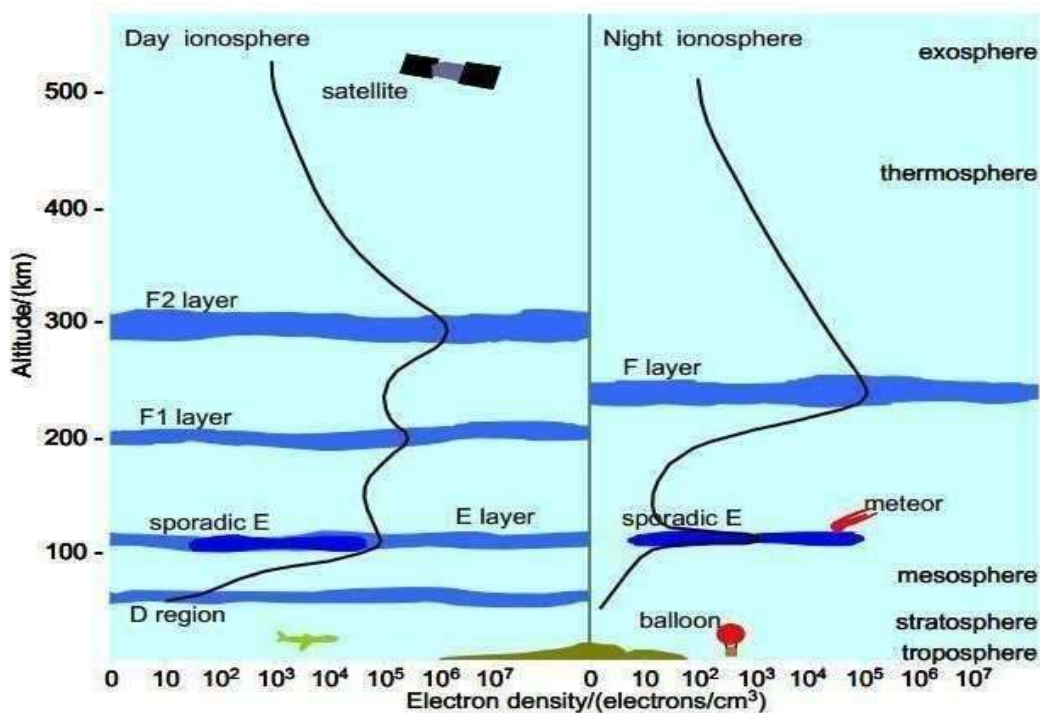

Critical Frequency

For any given time, each ionospheric layer has a maximum frequency at which radio waves can be transmitted vertically and refracted back to Earth. This frequency is known as the CRITICAL FREQUENCY. It is a term that you will hear frequently in any discussion of radio wave propagation.

Radio waves transmitted at frequencies higher than the critical frequency of a given layer will pass through the layer and be lost in space; but if these same waves enter an upper layer with a higher critical frequency, they will be refracted back to Earth. Radio waves of frequencies lower than the critical frequency will also be refracted back to Earth unless they are absorbed or have been refracted from a lower layer. The lower the frequency of a radio wave, the more rapidly the wave is refracted by a given degree of ionization. Figure 2-16 shows three separate waves of different frequencies entering an ionospheric layer at the same angle. Notice that the 5-megahertz wave is refracted quite sharply. The 20-megahertz wave is refracted less sharply and returned to Earth at a greater distance. The 100-megahertz wave is obviously greater than the critical frequency for that ionized layer and, therefore, is not refracted but is passed into space.

Maximum Usable Frequency

As we discussed earlier, the higher the frequency of a radio wave, the lower the rate of refraction by an ionized layer. Therefore, for a given angle of incidence and time of day, there is a maximum frequency that can be used for communications between two given locations. This frequency is known as the MAXIMUM USABLE FREQUENCY (muf).

Waves at frequencies above the muf are normally refracted so slowly that they return to Earth beyond the desired location, or pass on through the ionosphere and are lost. You should understand, however, that use of an established muf certainly does not guarantee successful communications between a transmitting site and a receiving site. Variations in the ionosphere may occur at any time and consequently raise or lower the predetermined muf. This is particularly true for radio waves being refracted by the highly variable F2 layer. The muf is highest around noon when ultraviolet light waves from the sun are the most intense. It then drops rather sharply as recombination begins to take place.

$$\therefore \sin \phi_i = \sqrt{1 - \frac{\delta N_{\max}}{f_{\text{muf}}^2}}$$

Squaring both sides

$$\sin^2 \phi_i = 1 - \frac{\delta N_{\max}}{f_{\text{muf}}^2}$$

$$\therefore \frac{\delta N_{\max}}{f_{\text{muf}}^2} = 1 - \sin^2 \phi_i = \cos^2 \phi_i$$

but $f_{\text{co}} = \sqrt{\delta N_{\max}}$

$$\therefore \frac{f_{\text{co}}^2}{f_{\text{muf}}^2} = \cos^2 \phi_i$$

$$\therefore \underline{f_{\text{muf}}} = \frac{f_{\text{co}}}{\cos \phi_i} = \underline{\sec \phi_i f_{\text{co}}}$$

The f_{muf} is always greater than f_{co} of the layer by the factor $\sec \phi_i$. This is called Secant law.

Lowest Usable Frequency

As there is a maximum operating frequency that can be used for communications between two points, there is also a minimum operating frequency. This is known as the LOWEST USABLE FREQUENCY (luf). As the frequency of a radio wave is lowered, the rate of refraction increases. So a wave whose frequency is below the established luf is refracted back to Earth at a shorter distance than desired, as shown in figure

The transmission path that results from the rate of refraction is not the only factor that determines the luf. As a frequency is lowered, absorption of the radio wave increases. A wave whose frequency is too low is absorbed to such an extent that it is too weak for reception. Likewise, atmospheric noise is greater at lower frequencies; thus, a low-frequency radio wave may have an unacceptable signal-to-noise ratio. For a given angle of incidence and set of ionospheric conditions, the luf for successful communications between two locations depends on the refraction properties of the ionosphere, absorption considerations, and the amount of atmospheric noise present.

Optimum Working Frequency

Neither the muf nor the luf is a practical operating frequency. While radio waves at the luf can be refracted back to Earth at the desired location, the signal-to-noise ratio is still much lower than at the higher frequencies, and the probability of multipath propagation is much greater. Operating at or near the muf can result in frequent signal fading and dropouts when ionospheric variations alter the length of the transmission path. The most practical operating frequency is one that you can rely on with the least amount of problems. It should be high enough to avoid the problems of multipath, absorption, and noise encountered at the lower frequencies; but not so high as to result in the adverse effects of rapid changes in the ionosphere. A frequency that meets the above criteria has been established and is known as the OPTIMUM WORKING FREQUENCY. It is abbreviated "fot" from the initial letters of the French words for optimum working frequency, "frequence optimum de travail." The fot is roughly about 85 percent of the muf but the actual percentage varies and may be either considerably more or less than 85 percent.

Skip Distance/Skip Zone

The relationship between the sky wave skip distance, the skip zone, and the ground wave coverage. The SKIP DISTANCE is the distance from the transmitter to the point where the sky wave is first returned to Earth. The size of the skip distance depends on the frequency of the wave, the angle of incidence, and the degree of ionization present.

The SKIP ZONE is a zone of silence between the point where the ground wave becomes too weak for reception and the point where the sky wave is first returned to Earth. The size of the skip zone depends on the extent of the ground wave coverage and the skip distance. When the ground wave coverage is great enough or the skip distance is short enough that no zone of silence occurs, there is no skip zone. Occasionally, the first sky wave will return to Earth within the range of the ground wave. If the sky wave and ground wave are nearly of equal intensity, the sky wave alternately reinforces and cancels the ground wave, causing severe fading. This is caused by the phase difference between the two waves, a result of the longer path traveled by the sky wave.

$$D_{\text{skip}} = 2h \sqrt{[(f_{\text{muf}}/f_c)^2 - 1]}$$

MULTI -HOP PROPAGATIONS

The coverage of transmission distance between transmitter and receiver in more than one hop is called multi-hop propagation.

The longest single hop propagation is obtained when the transmitted ray is tangential at the earth surface.

The maximum practical distance covered by a single hop is 2000 km for E layer and 4000 km for F2 layer.

Multi-hop propagation paths occur when the semicircumference of the earth is just over 20,000 km.

VIRTUAL HIGHT

Defined as the height to which a short pulse of energy sent vertically upward.

It will always be greater than the actual height.

If it is known, it is easy to calculate the angle of incidence required for the wave to return at a desired point.

The measurement of virtual height is normally carried out by means of an instrument known as ionosonde.

$$H = CT/2, C - \text{velocity of light, } T - \text{Round trip time.}$$

METHOD OF VIRTUAL HIGHT MEASUREMENT

Transmit a signal that consists pulses of RF energy of short duration.

Receiver which is located close to the transmitter picks up both the direct and the reflected signals.

The spacing between these signals on the time axis of CRO gives a measurement of the height of the layer.

Useful in transmission path calculations.